

ASNIERES

92600

CONSTRUCTION D'UN ENSEMBLE DE LOGEMENTS COLLECTIFS ET PARKINGS

57-61 ,rue Emile zola
92600 ASNIERES SUR SEINE

MAITRE D' OEUVRE	MAITRE D'OUVRAGE
ACP 85, Rue Mouffetard 75005 -PARIS ☎: 01.53.17.09.00 📠: 01.53.17.08.00	CFH - SCI ASNIERS PARC 50, Route de la Reine 92773 -BOULOGNE-BILLANCOURT ☎: 01.55.60.45.45 📠: ...
BUREAU DE CONTROLE	ENTREPRISE G.O.
APAVE 14 Chaussée Jules César OSNY BP 235 95523 - CERGY PONTOISE CEDEX ☎: 01.45.66.17.42 📠: 01	BMC Gros-oeuvre - Maçonnerie 18 RUE TRIPIER 93130 NOISY-LE-SEC Tél: 01.41.61.08.48 Fax: 01.41.61.08.08

CLÔTURE - COUPE ET DETAILS

ind.	date	modifications
0	13-04-17	1 ère diffusion.

	DOSSIER	PLAN	APD	
	280	C.105	IND.	
			EXE	X
			DOE	
	Ingenieur	Projeteur	Date	Echelle
	H.B.F	13/04/17	1/25	

COUPE 1-1

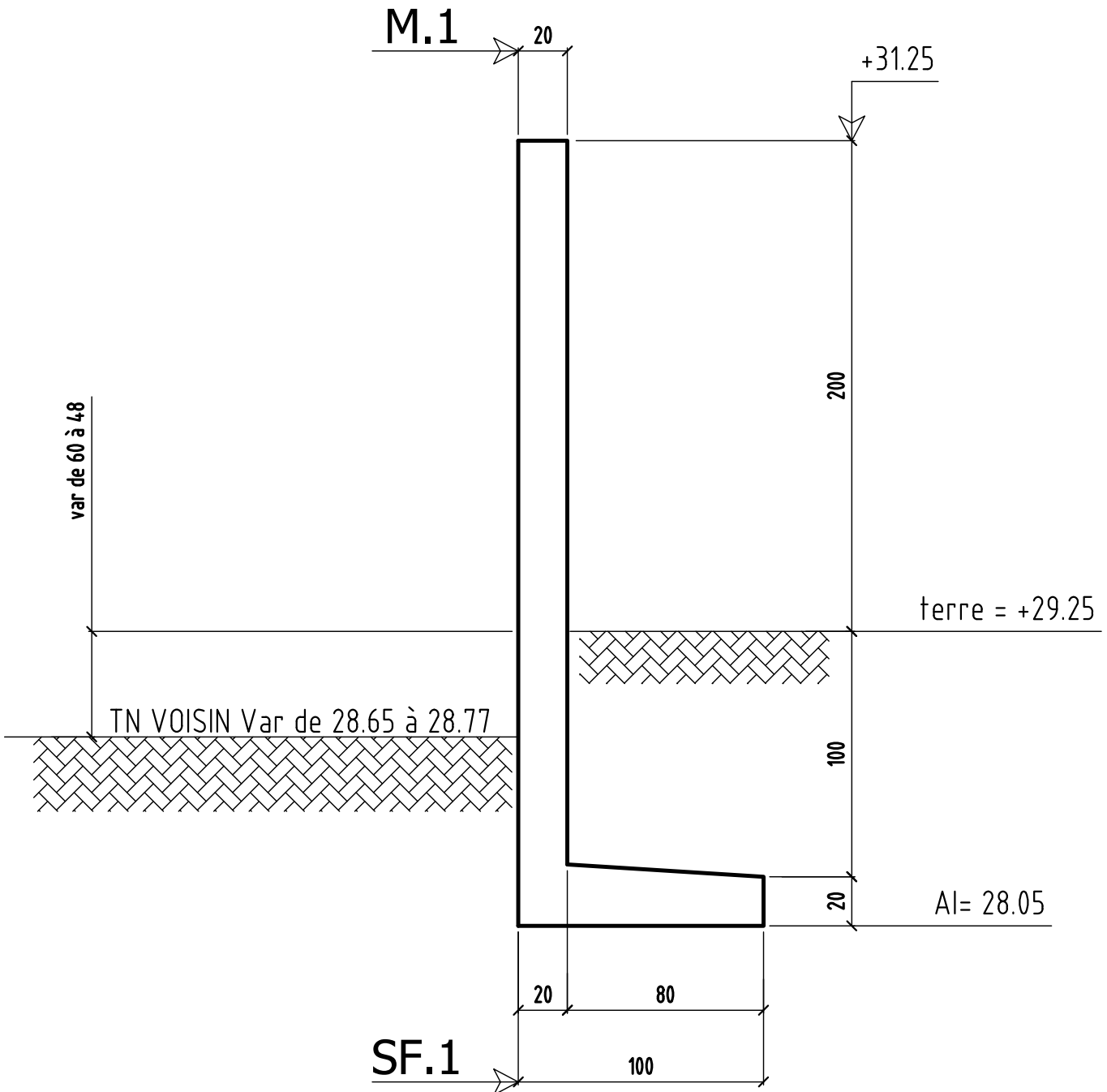

COUPE 2-2

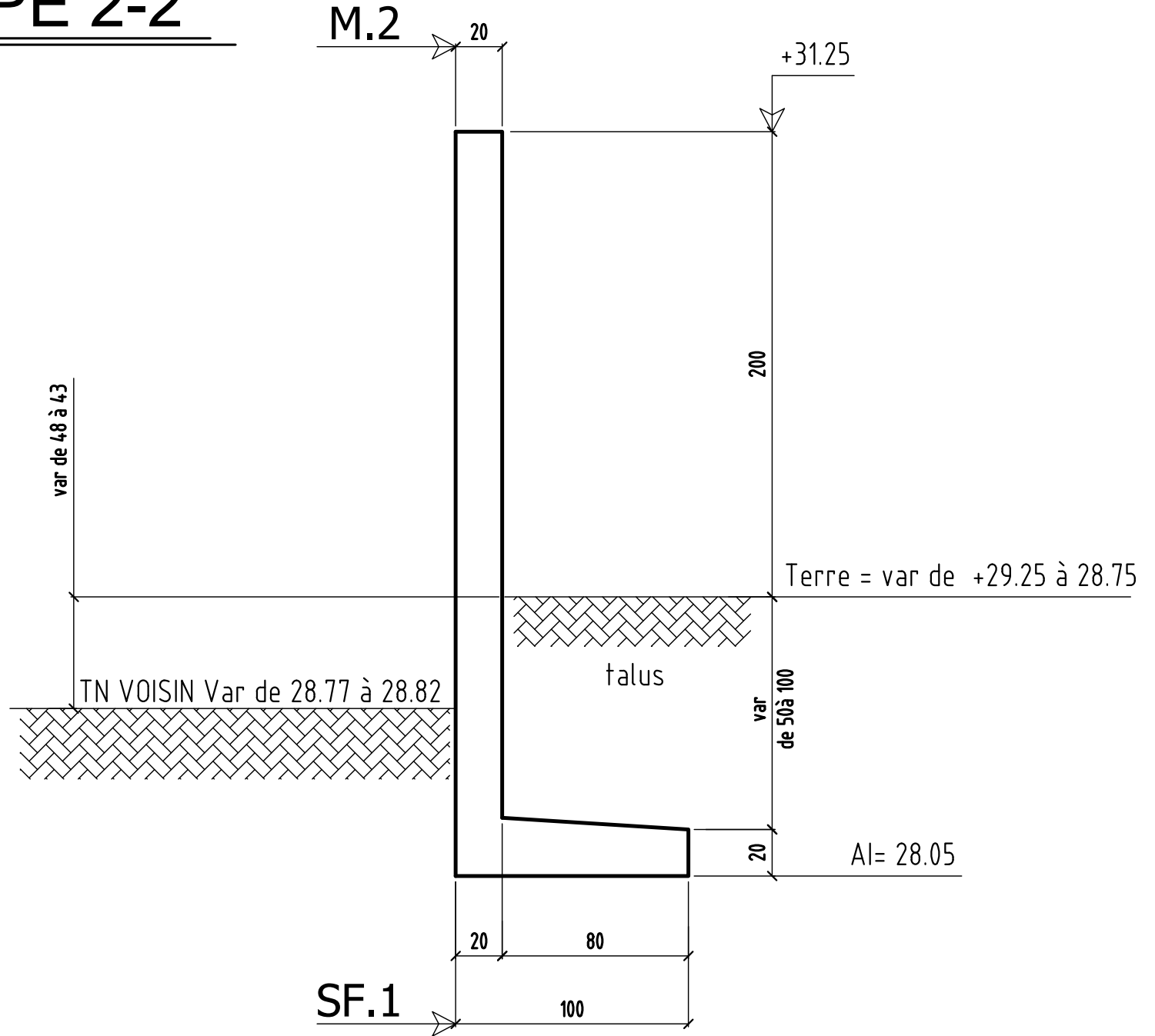

COUPE 2-2

MODIFICATIONS
0

A
B

AFFAIRE: 280
Ech: 1/25

Cahier C.105
Page 02

COUPE 3-3

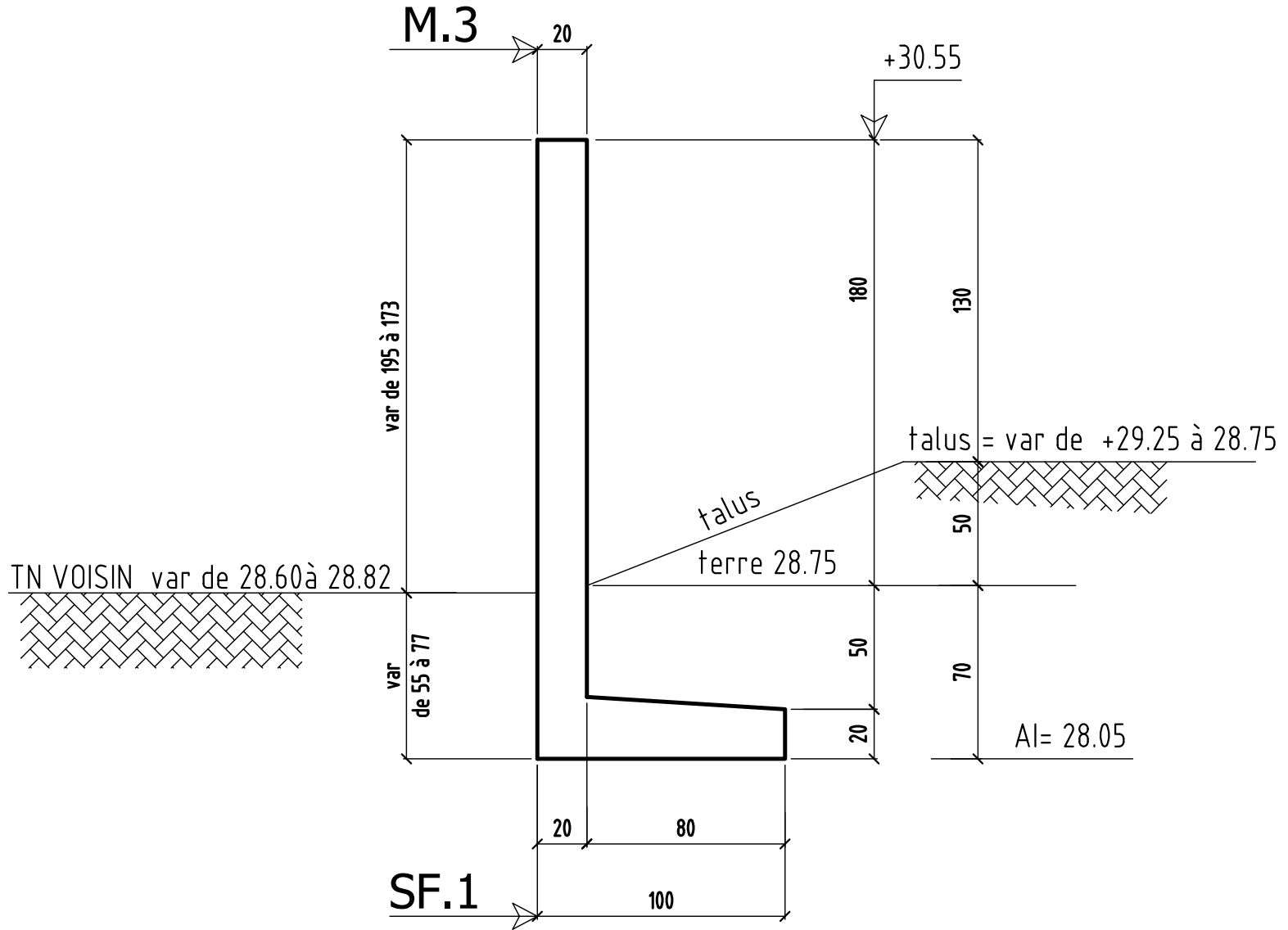

COUPE 3-3

0

MODIFICATIONS

B

A

Ech: 1/25

AFFAIRE: 280

Page 03

Cahier C.105

COUPE 5-5

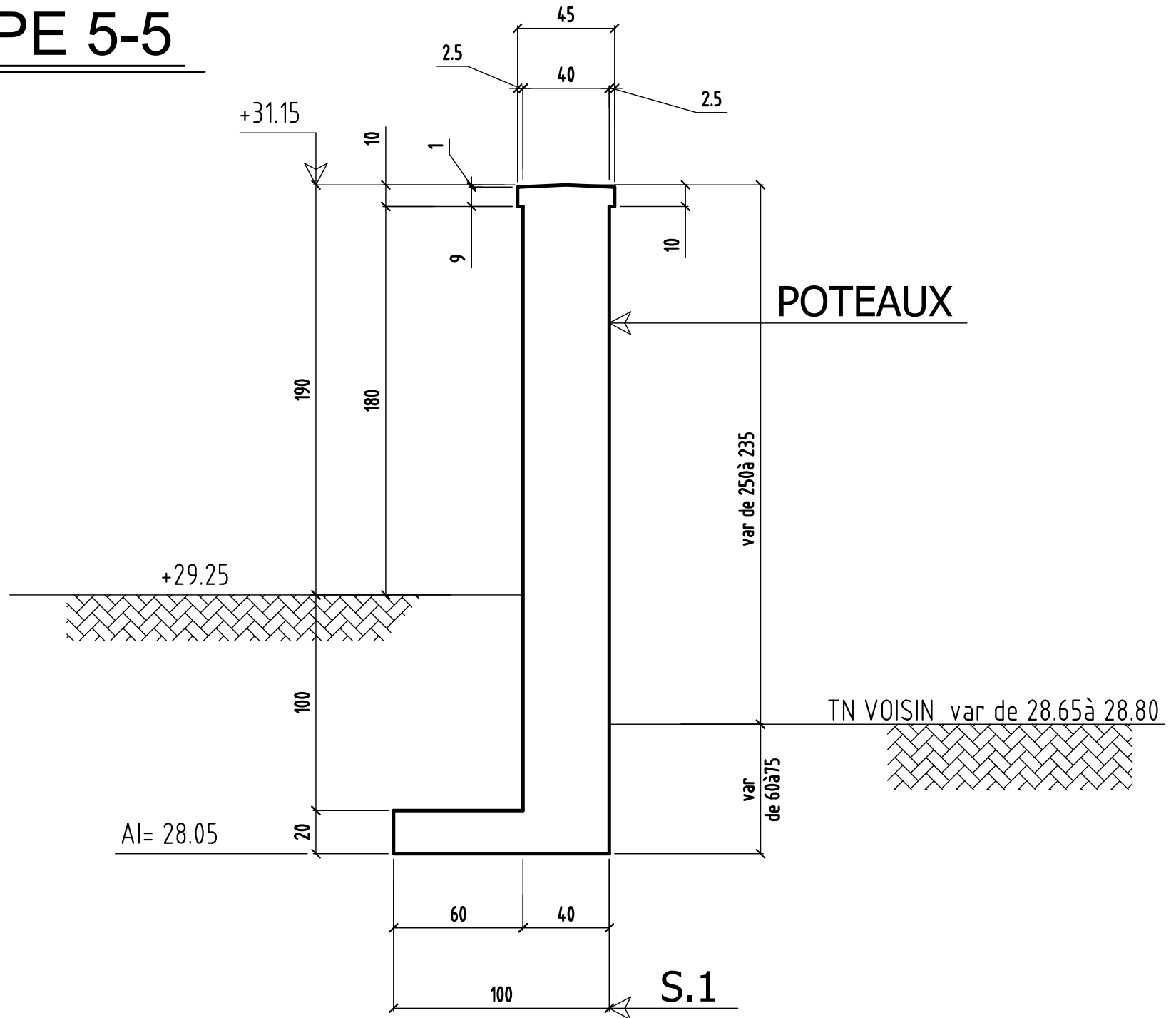

COUPE 5-5

0

MODIFICATIONS

B

A

Ech: 1/25

AFFAIRE: 280

Page 05

Cahier C.105

COUPE 7-7

COUPE 7-7

0

MODIFICATIONS

B

A

Ech: 1/25

AFFAIRE: 280

Page 07

Cahier C.105

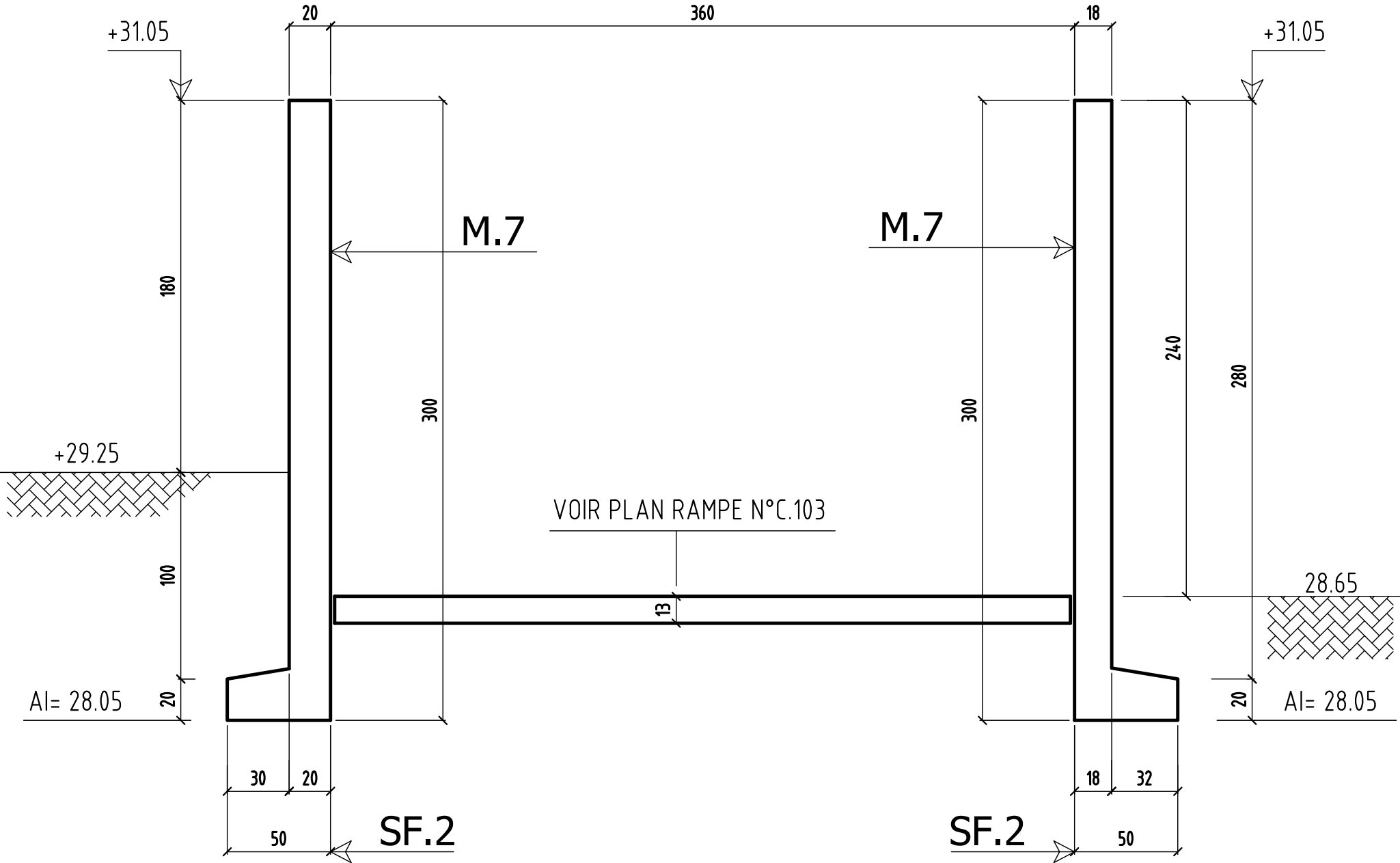

COUPE 8-8

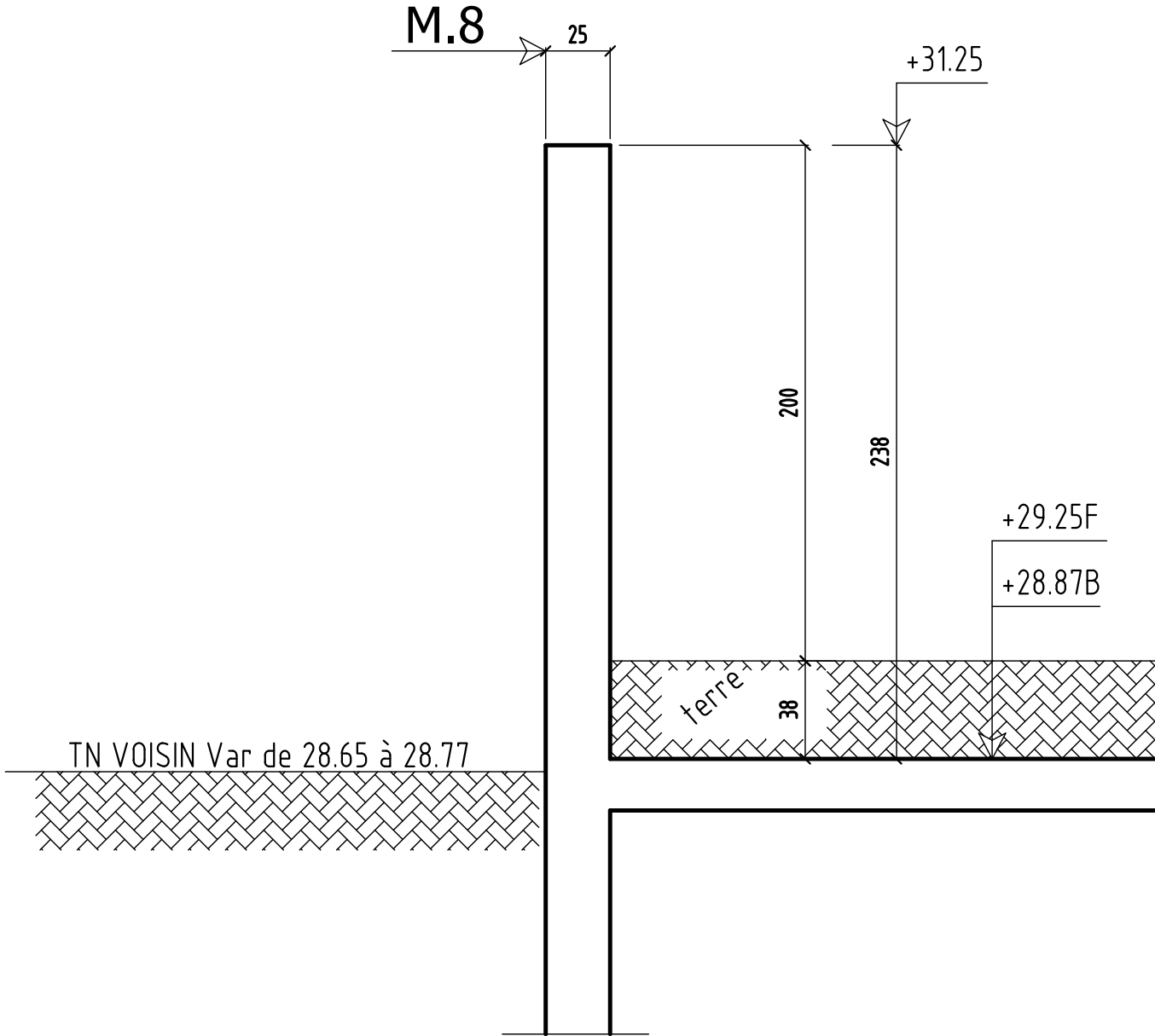

COUPE 8-8

0 MODIFICATIONS

A B

AFFAIRE: 280
Ech: 1/25

Cahier C.105
Page 08

COUPE 9-9

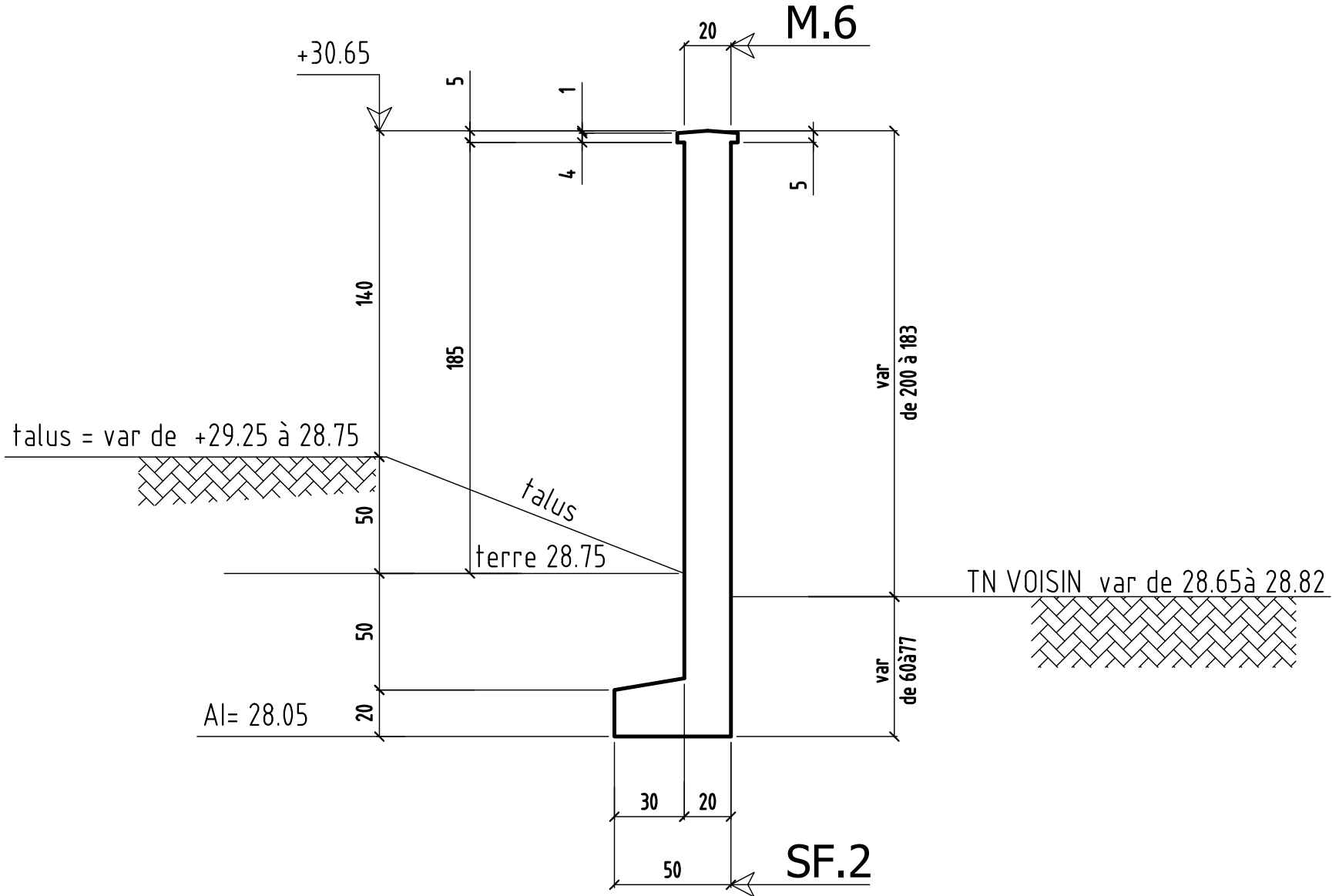

COUPE 9-9

MODIFICATIONS
0

A
B

AFFAIRE: 280
Ech: 1/25

Cahier C.105
Page 09