



VOIR PLAN N° : C.26 - Coupes et détails

COUPE FEU : PLANCHERS CF + 2 HEURE  
STABLE AU FEU VERTICAUX SF + 2 HEURE

SURCHARGES D'EXPLOITATION:  
LOGEMENTS : 150 DaNm<sup>2</sup>  
PARTIES COMMUNES : 250 DaNm<sup>2</sup>  
JARDINS ET TERRASSES : 250 DaNm<sup>2</sup>  
BALCONS : 100 DaNm<sup>2</sup>

CHARGES PERMANENTES:  
LOGEMENTS (meublements + objets) : 150 DaNm<sup>2</sup>  
JARDINS (Tentes sautoies) : 2000 DaNm<sup>2</sup>

PRECONISATIONS DES BETONS:  
NORME NF EN 206-1 en vigueur  
Béton apparent : XF1 C25/30 Fc28 = 25 Mpa  
Béton Voies sous terre : XF1 C25/30 Fc28 = 25 Mpa  
Gros Béton : XF1 C16/20 Fc28 = 20 Mpa  
sauf ces cotations indiqués sur le vue en plan

Eléments de structure	
Béton porteur	
Poteaux royaux	
Poteaux porteurs	
Poutres béton armé	
Béton Non Porteur	
Maçonnerie Pierre Porteuse	
Maçonnerie Creuse Porteuse	
Maçonnerie Pierre Non Porteuse	
Maçonnerie Creuse Non Porteuse	
Béton Pré-tendu	
Impact des voiles béton porteur	
Impact garde-corps et rebords BA	
Complexes et revêtements	
Gros Béton et recharges	
Dalles sur plots	
Terre, pétales	
Jardinières	
A : Enfon	DAP : Dalle Alvéolaire Précontrainte
WSP : Vase	S.L.C. : Sautoie-Cave
Lg : Longrine	Tr : Trumeau
C : Chevêtre	M : Muret
Ch : Charge	P : Poteau
L : Linteau	PR : Poteau royal
Lib : Libage	S : Semelle
BN : Bando-royale	SF : Semelle Tante
	R : Raidisseur
	V : Voie
	Vc : Voie contre terre
	T : Tronç
	PVP : Arrière Poutre V
	PV : Poutre-voie

SAINT-LEU-LA FORET 95320  
**CONSTRUCTION D'UN ENSEMBLE DE LOGEMENTS COLLECTIF**  
 5 / 7 , Sente du bas trouillard  
 17 / 29 , rue gambetta  
 4 / 6 , rue guynemer  
 département du val deoise-95320

<b>MAITRE D'OUVRE</b> <b>ELLEBOODE architecture</b> 26 RUE BERTHOUD-75005 PARIS ☎ 01.44.34.44.34 ☎ 01.45.04.60.11	<b>MAITRE D'OUVRAGE</b> <b>SCV GAMBETTA</b> 38bis Avenue du général de Gaulle 93110 BOSSY-SOUS-BOIS ☎ 01.48.54.51.09 ☎ 01.48.55.84.15
<b>BUREAU DE CONTROLE</b> <b>QUALICONSULT</b> 82007 PONTAINE ☎ 01.68.38.93.00 ☎ 06.88.58.28.04 mail : sabin@qualiconsult.fr	<b>ENTREPRISE G.O.</b> <b>M.T.R</b> 9, rue René Cassin 77173 CHEVREY-COSSY ☎ 01.60.82.32.00 ☎ 01.60.82.32.01

VUE EN PLAN - PHT 2 ETAGE  
 COFFRAGE  
 bts : A & B

ind.	date	modifications
0	11-12-17	1 ère diffusion.
A	05-07-18	Mise à jour générale.

DOSSIER		PLAN		AFD	
297	C.26	IND.	PRO		
Ingenieur	Projeteur	EXE	DOE		
H.B.E.	11/12/17	Echelle	1/50		





SAINT-LEU-LA FORET

95320

# CONSTRUCTION D'UN ENSEMBLE DE LOGEMENTS COLLECTIF

5 / 7 , Sente du bas troupillard  
17 / 29 , rue gambetta  
4 / 6 , rue guynemer  
département du val d'oise-95320

MAITRE D' OEUVRE	MAITRE D'OUVRAGE
<b>ELLEBOODE architecture</b> 26 RUE berthollet-75005 PARIS ☎: 01.44.34.44.34 ☎: 01.45.04.60.11	<b>SCCV GAMBETTA</b> 38bis, Avenue du général de Gaulle 93110 ROSNY-SOUS BOIS ☎: 01.48.94.51.09 ☎: 01.48.55.64.15
BUREAU DE CONTROLE	<b>ENTREPRISE G.O.</b>
<b>QUALICONSULT</b> 13 rue charles cros 93297 TREMBLAY EN FRANCE ☎: 01.48.19.93.00 ☎: 06.88.50.28.04 mail ; sebastien.cipoire@qualiconsult.fr	<b>M.T.R</b> 9, rue René Cassin 77173 CHEVRY-COSSIGNY ☎: 01.60.62.32.00 ☎: 01.60.62.32.01

PL HAUT 2 etage  
BATIMENTS (A) & (B) COUPES (coffrage)

ind.	date	modifications
0	16-07-18	1 ère diffusion.

	DOSSIER		PLAN		APD
	297		C.26		IND.
					EXE
	Ingenieur		Projeteur	Date	Echelle
			H.B.E	16/07/18	1/25

# COUPE 41-41

Bt: B

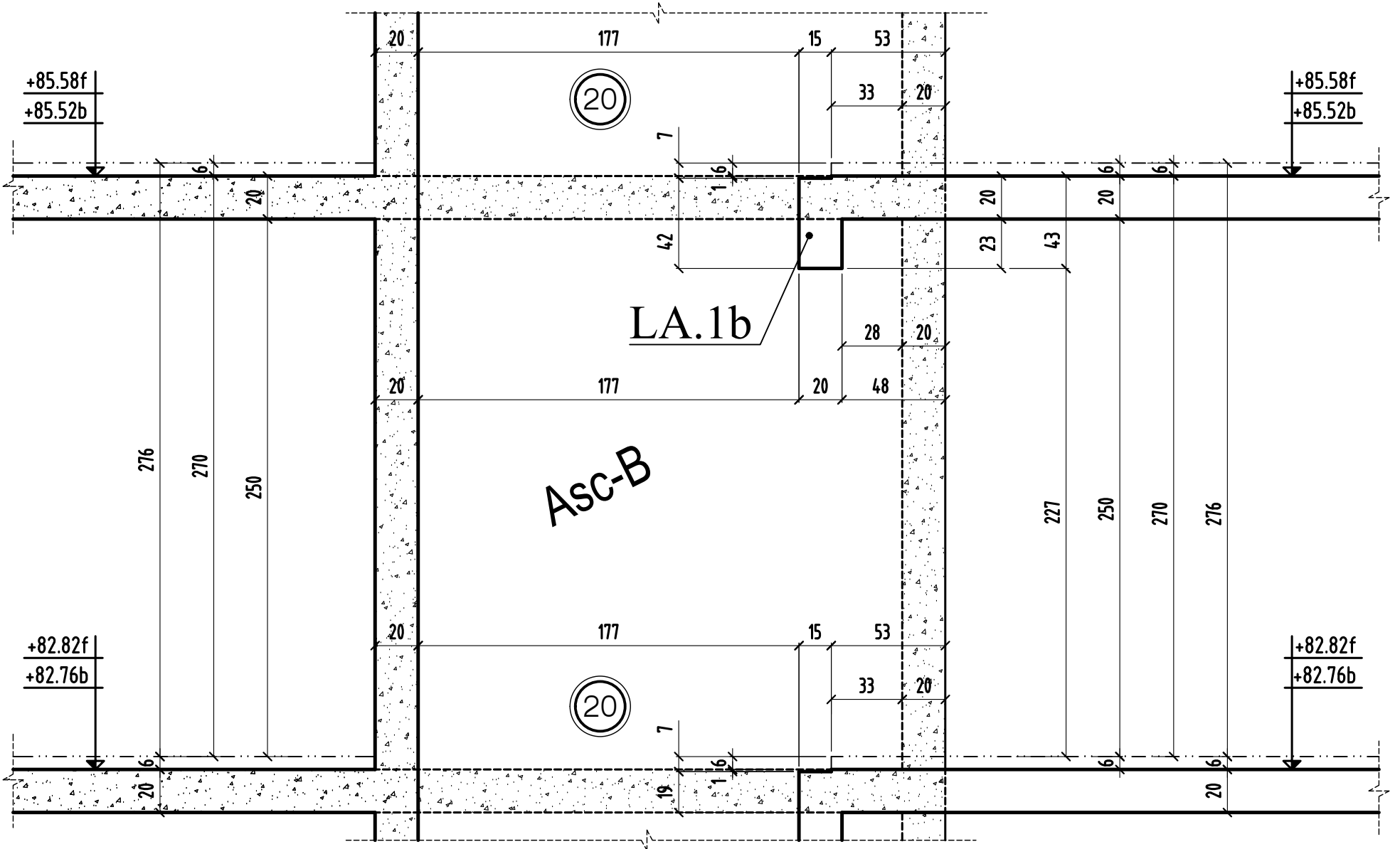

COUPE 41 - 41

MODIFICATIONS

A  
B

AFFAIRE: 297  
Ech: 1/25

Cahier C.26  
Page 01

COUPE 42 - 42

MODIFICATIONS

A  
B

AFFAIRE: 297  
Ech: 1/25

Cahier C.26  
Page 02

COUPE 42-42

Bt: B

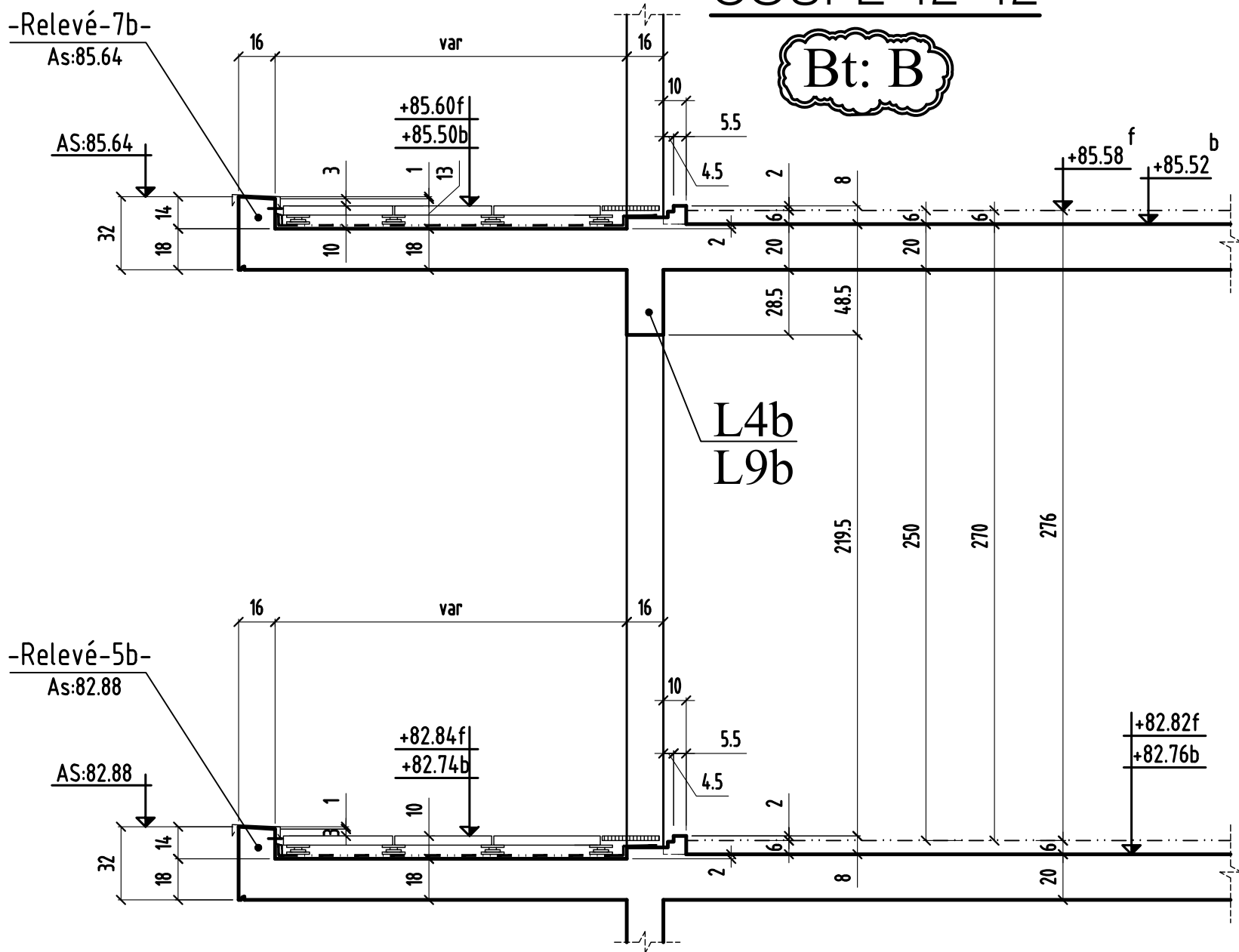

# COUPE 43-43

Bt: B

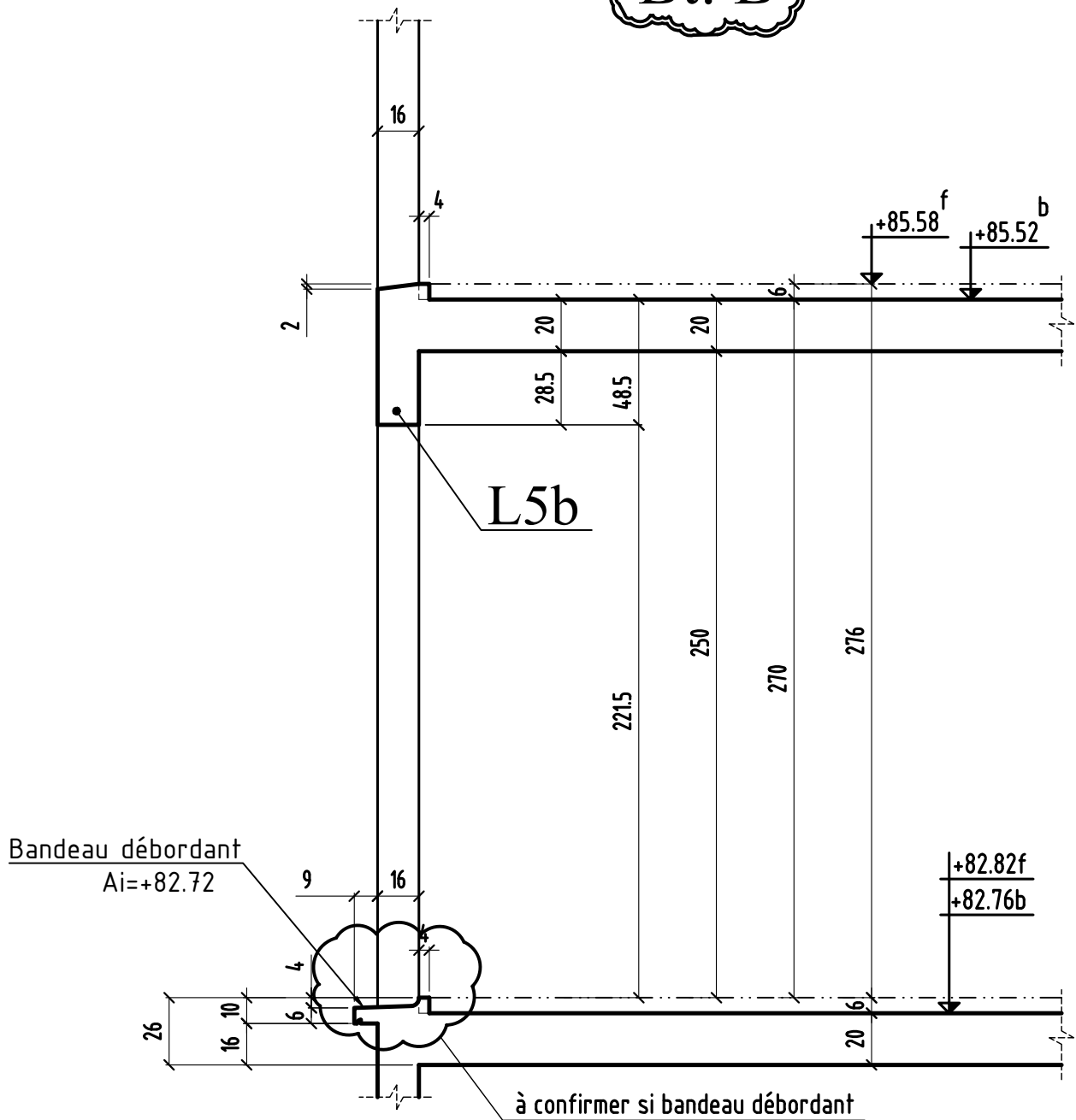





# COUPE 45-45

Bt: B

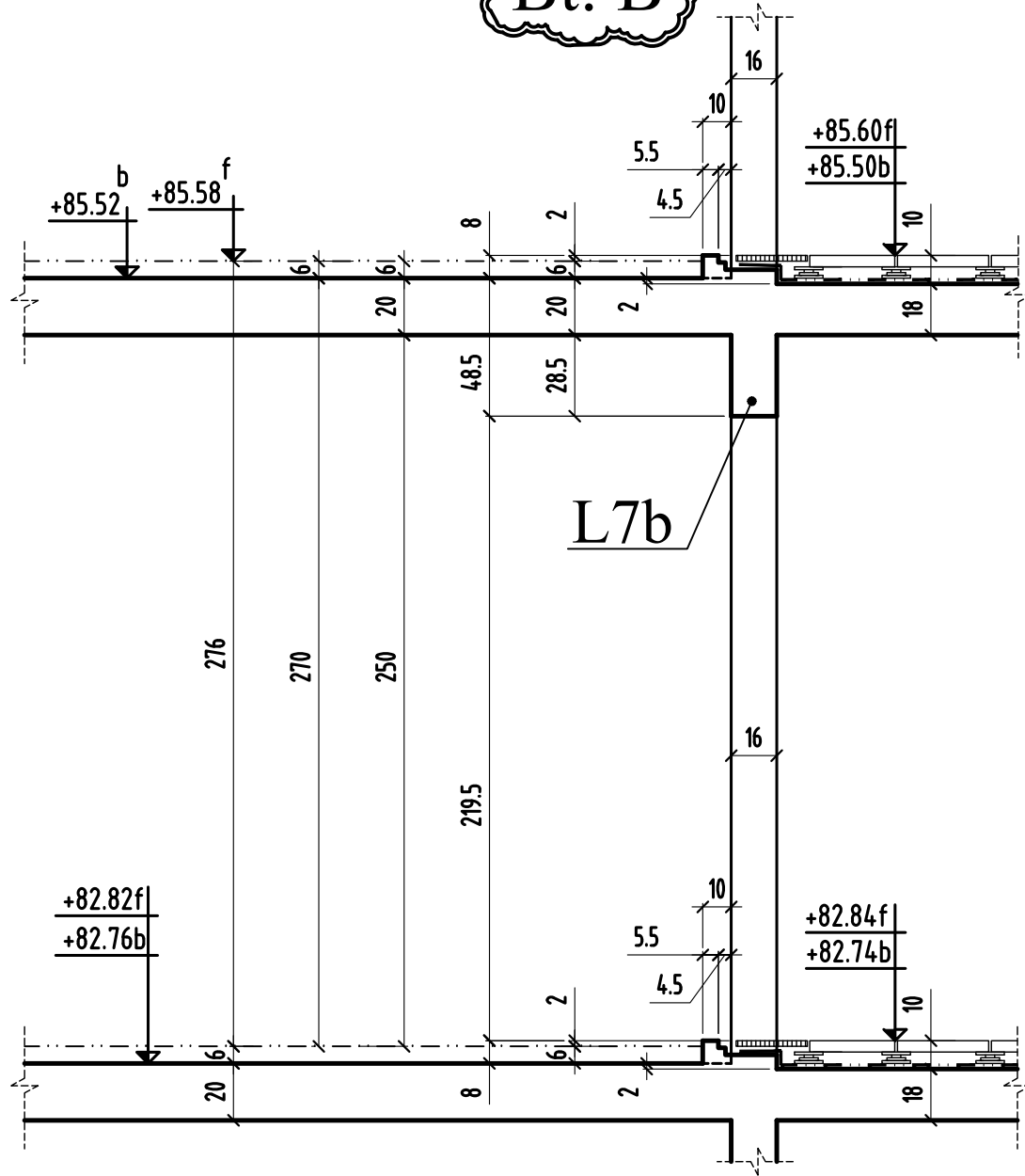

COUPE 45 - 45

01	MODIFICATIONS	A	AFFAIRE: 297	Cahier C.26
		B	Ech: 1/25	Page 05

# COUPE 46-46

Bt: B

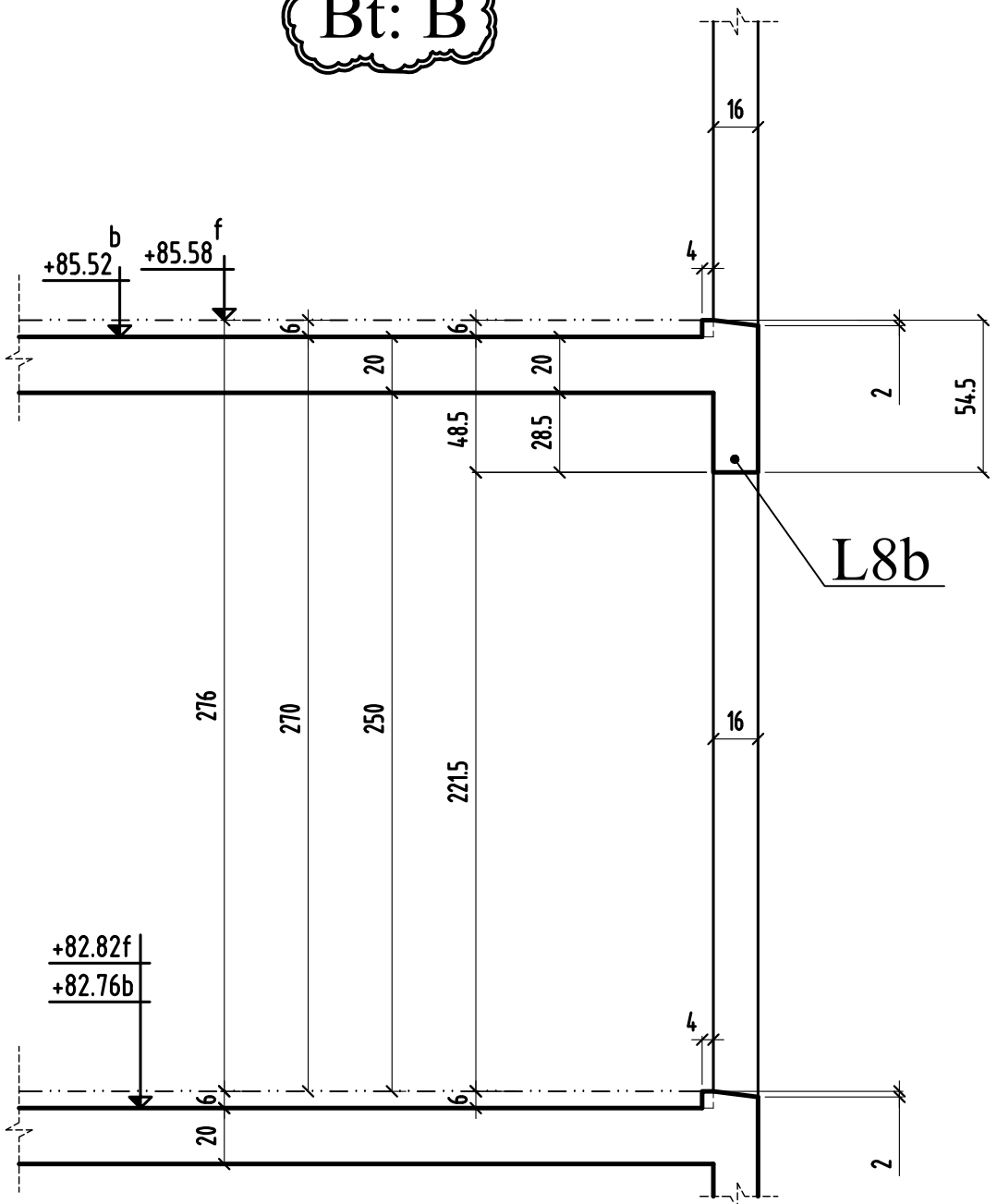

COUPE 46 - 46

01	MODIFICATIONS	A		AFFAIRE: 297	Cahier C.26
		B		Ech: 1/25	Page 06

# COUPE 47-47

Bt: B

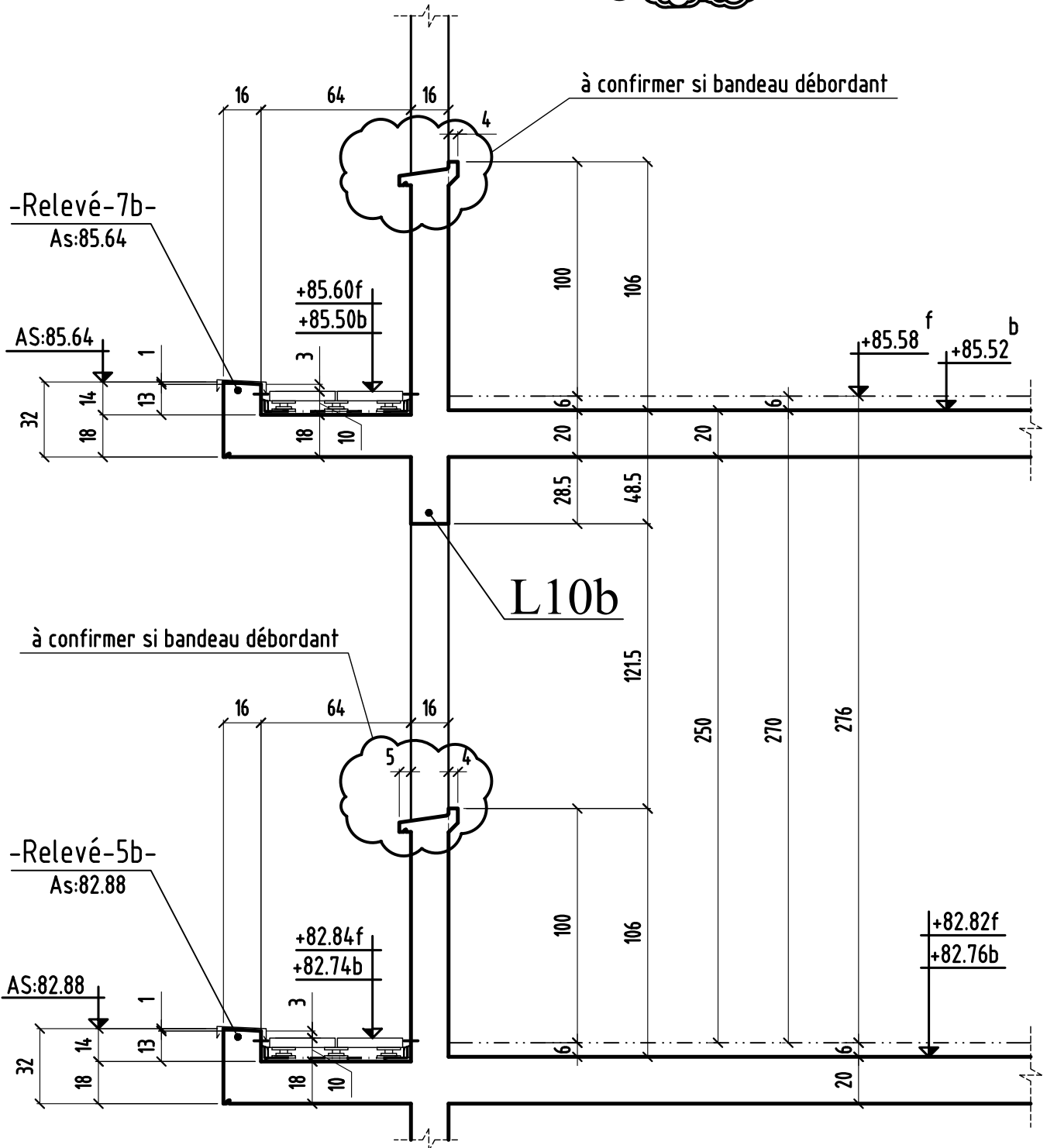

# COUPE 48-48

Bt: B

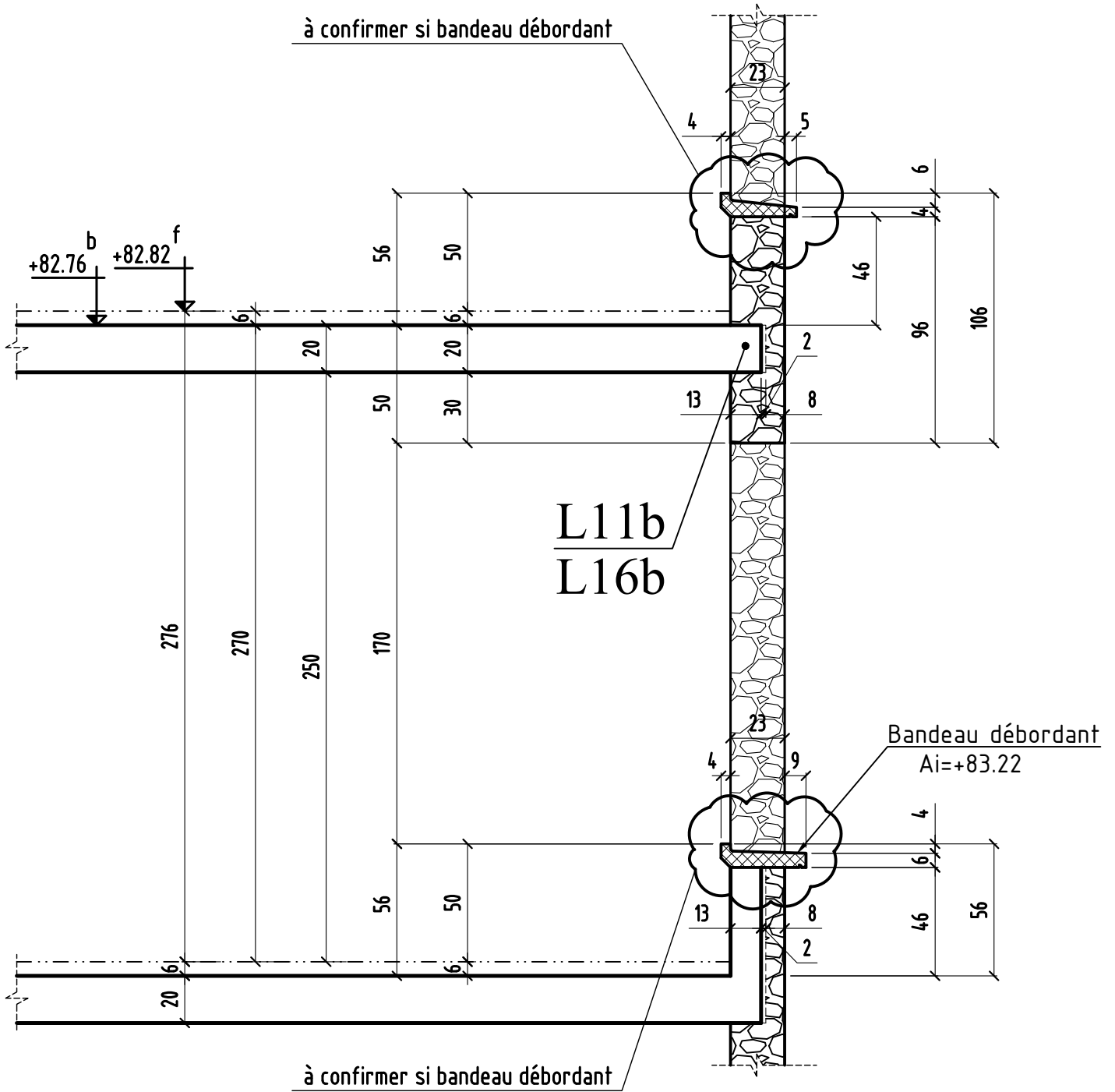

# COUPE 49-49

Bt: B

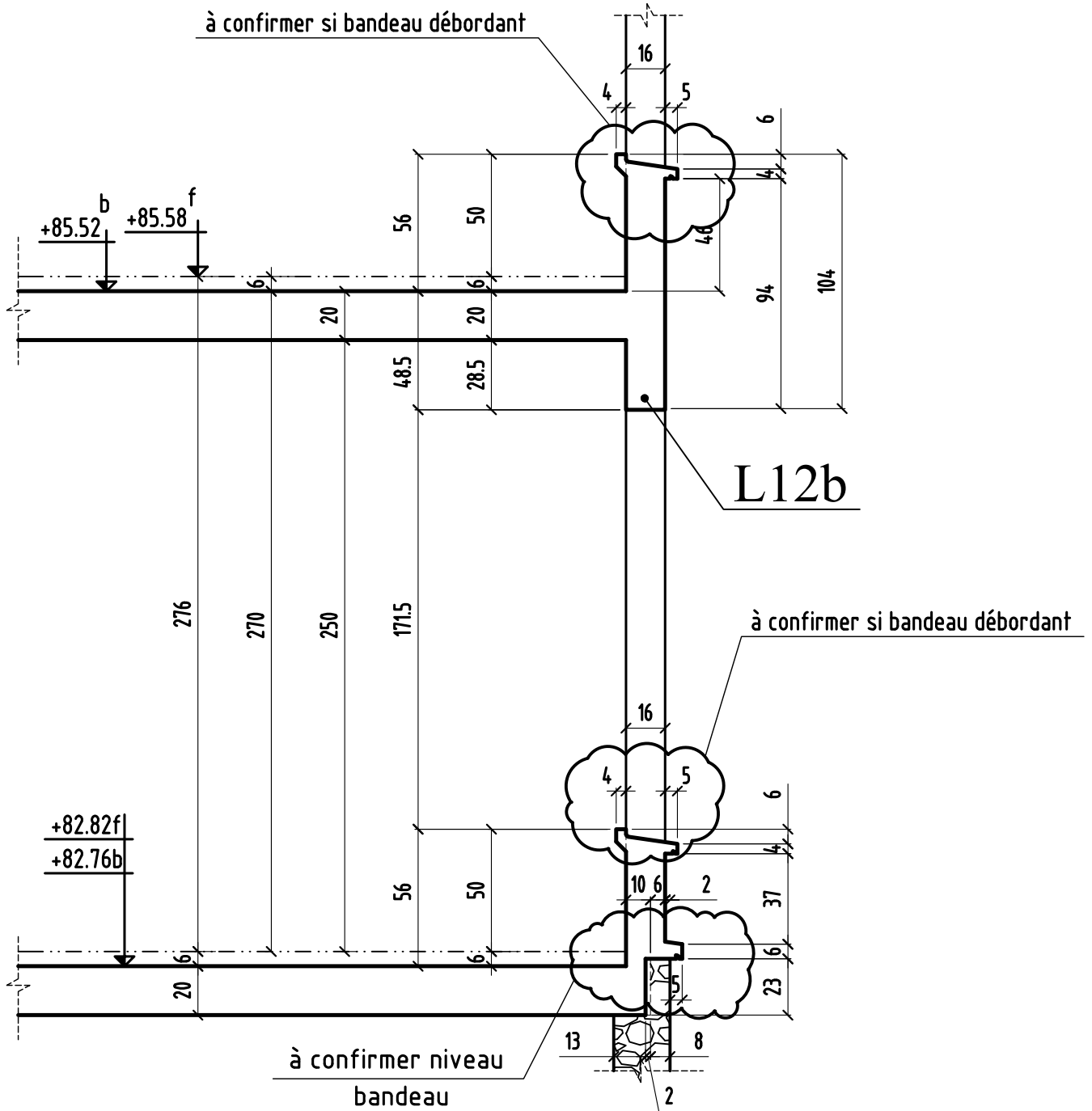



# COUPE 51-51

Bt: B

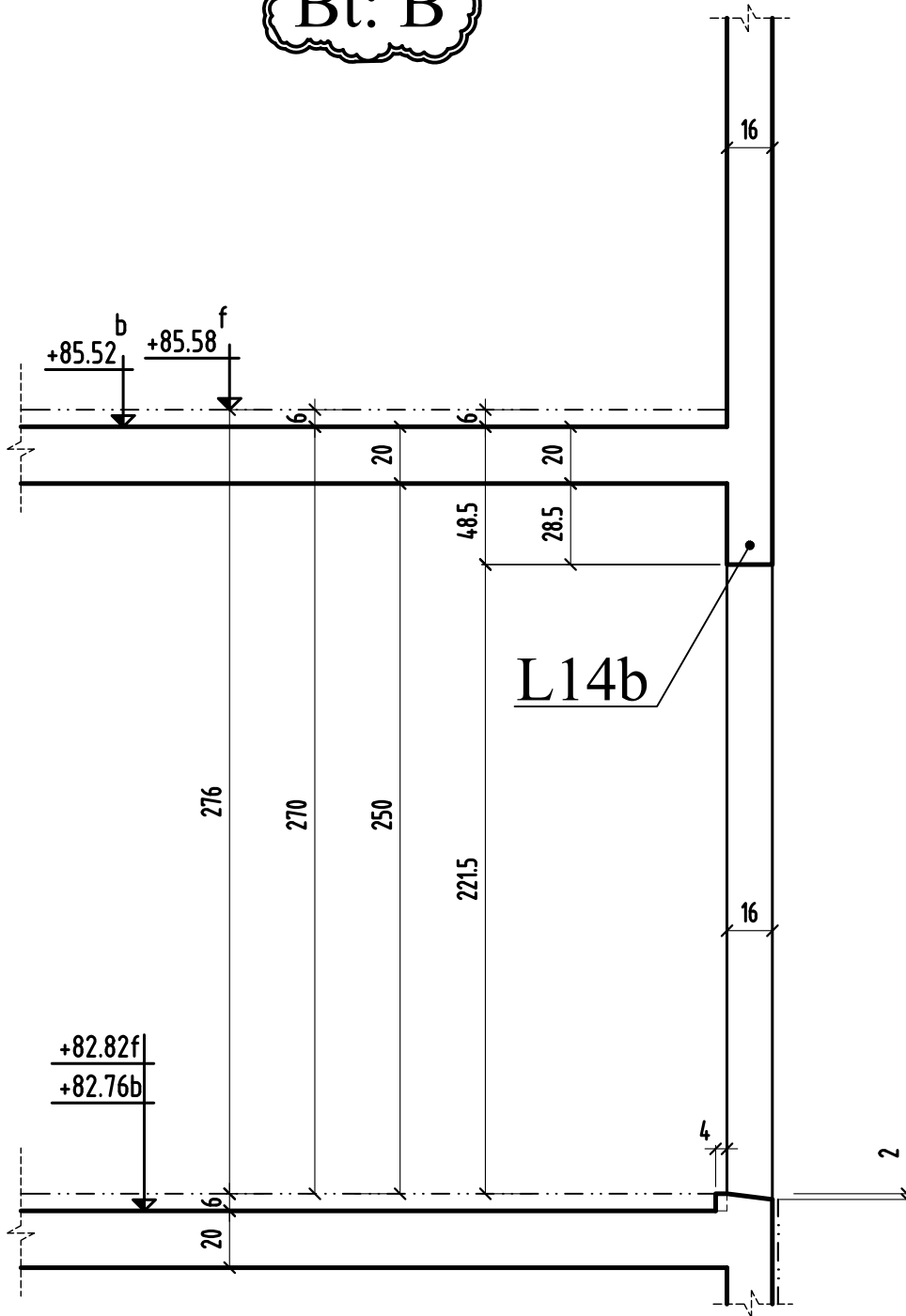

# COUPE 52-52

Bt: B

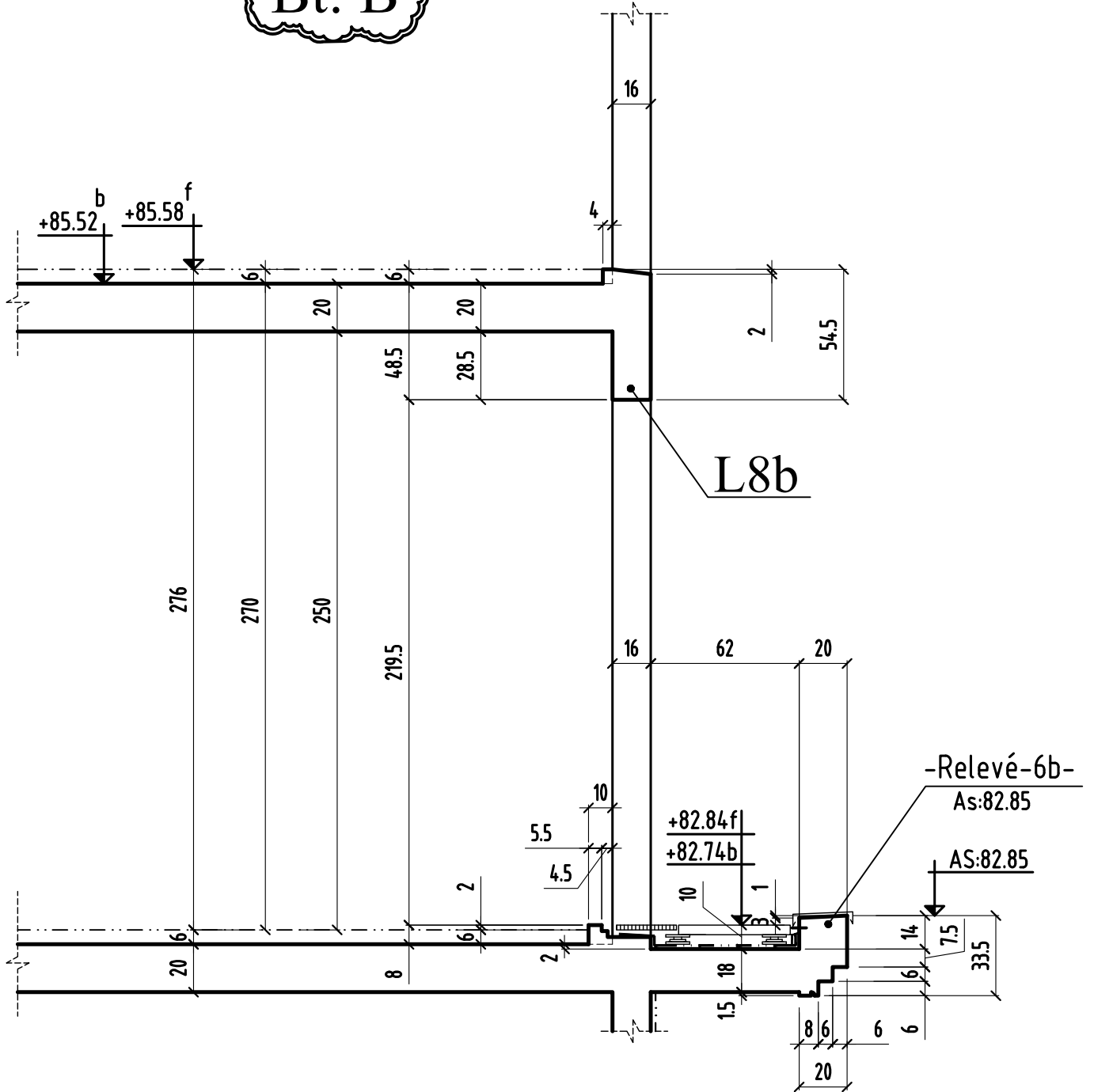



# COUPE 53-53

Bt: A

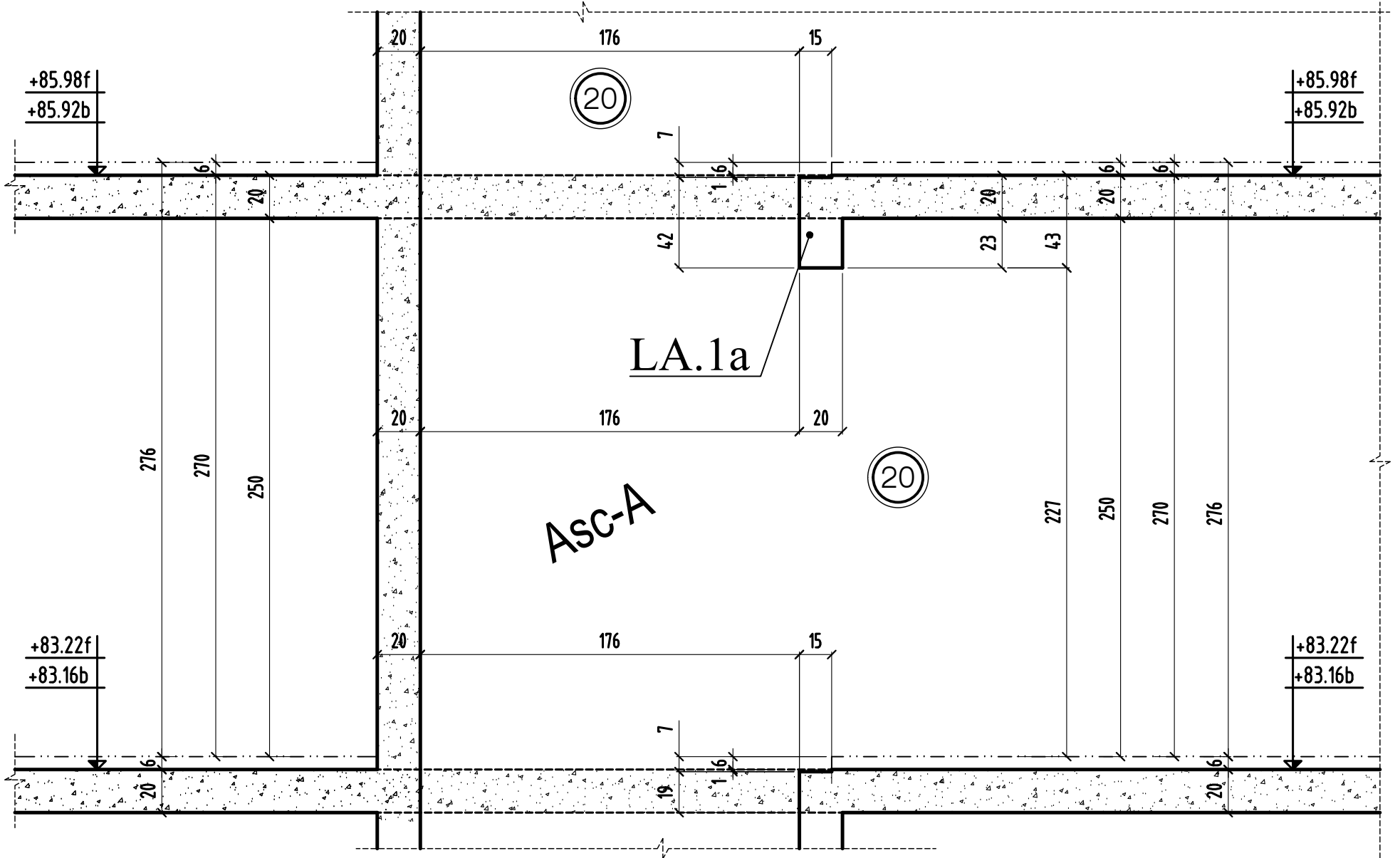

COUPE 53 - 53

MODIFICATIONS  
01

A  
B

AFFAIRE: 297  
Ech: 1/25

Cahier C.26  
Page 13

# COUPE 54-54

Bt: A

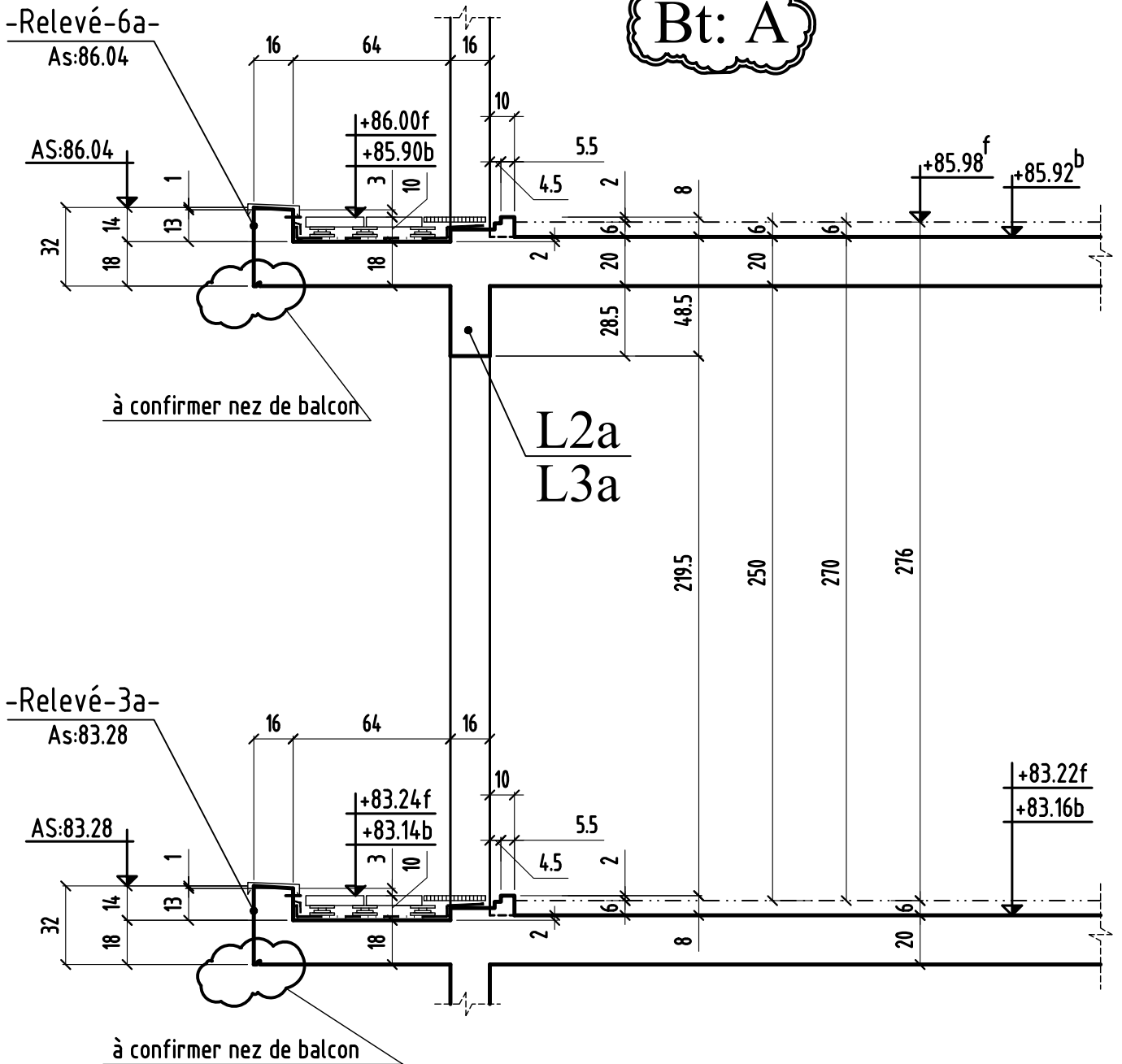

# COUPE 55-55

Bt: A

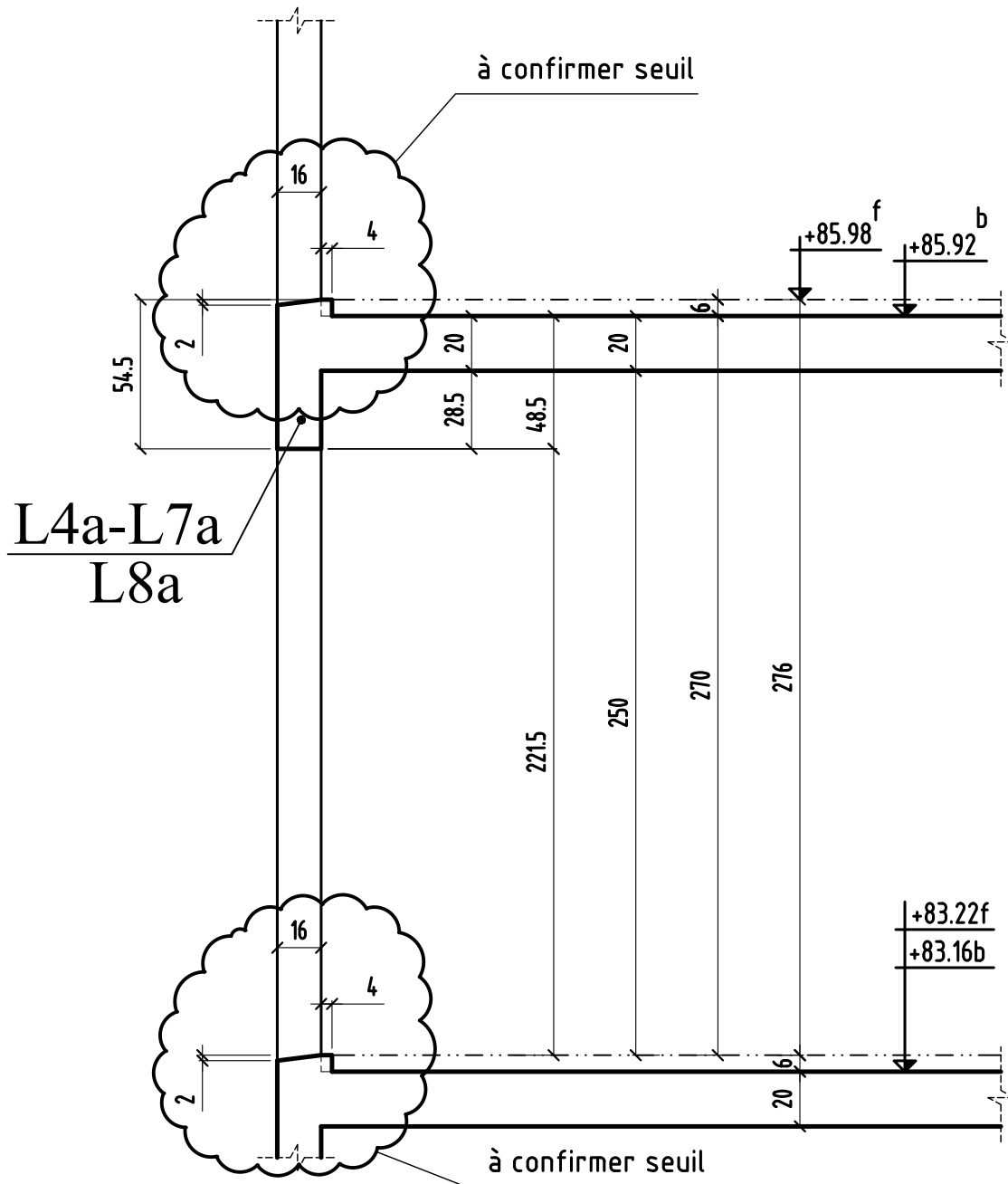

# COUPE 56-56

Bt: A

à confirmer si bandeau débordant

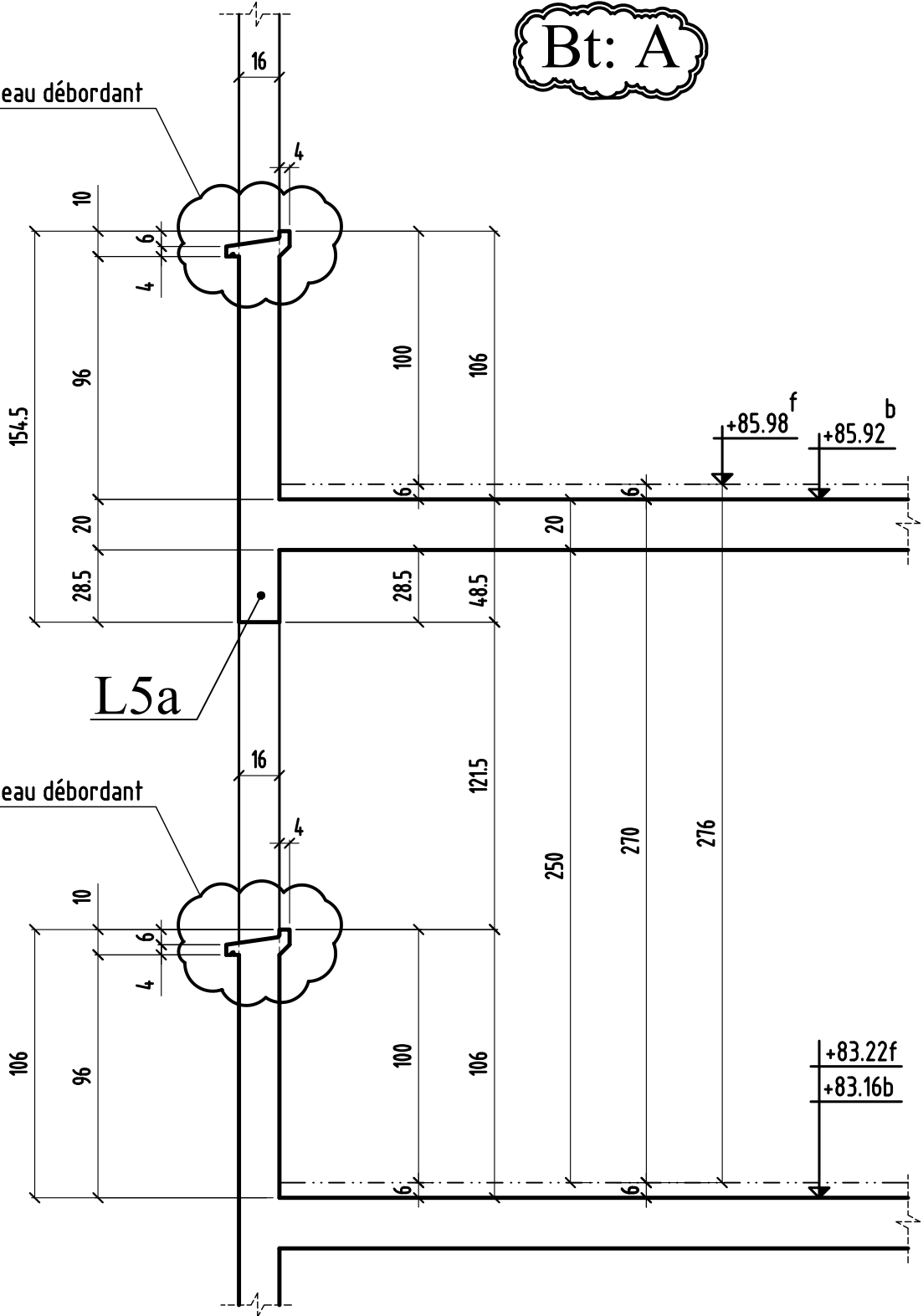

à confirmer si bandeau débordant



COUPE 58-58

Bt: A

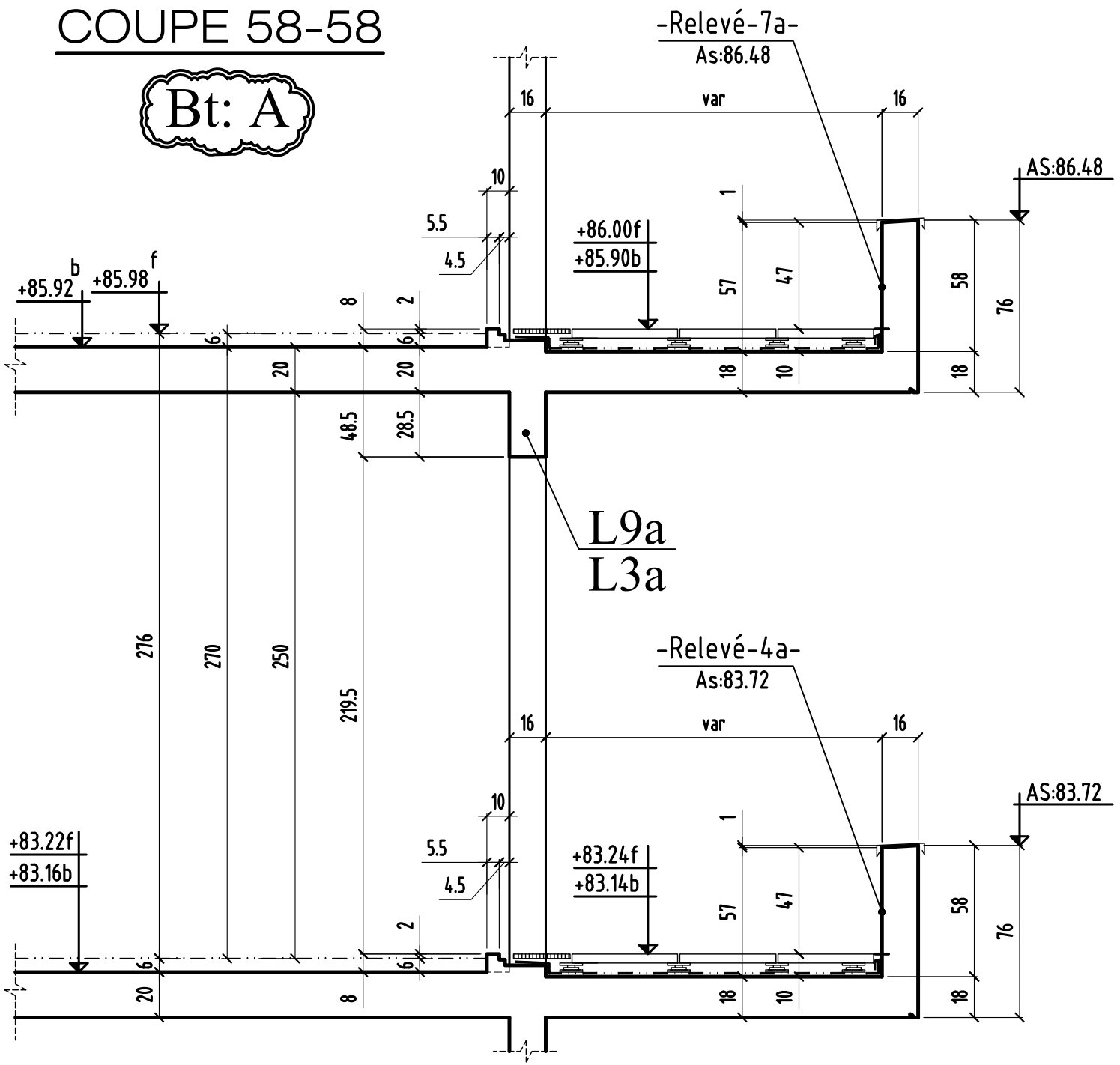

-Relevé-7a-  
As:86.48

+86.00f  
+85.90b

AS:86.48

L9a  
L3a

-Relevé-4a-  
As:83.72

+83.24f  
+83.14b

AS:83.72

# COUPE 59-59

Bt: A

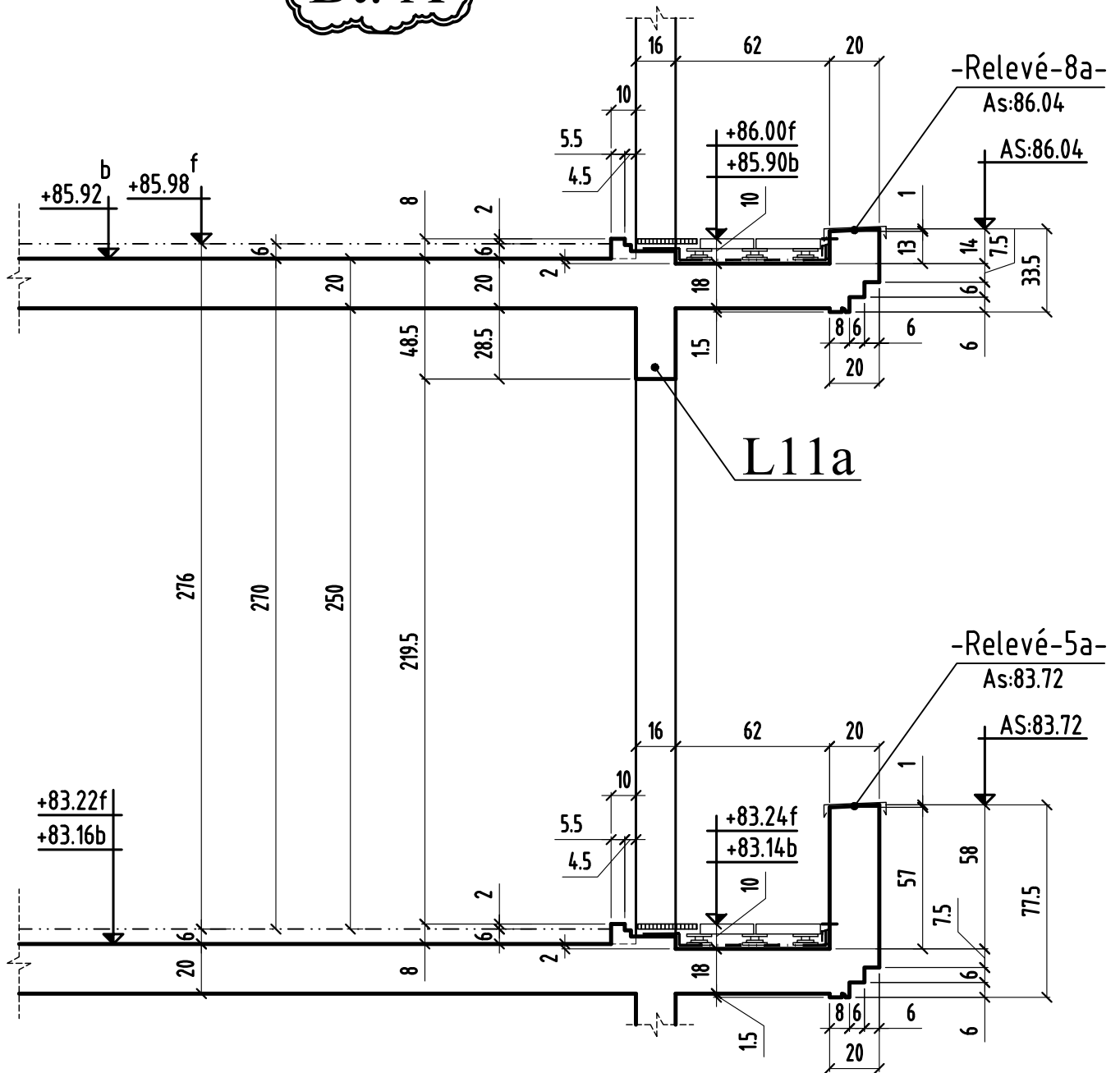

# COUPE 60-60

Bt: A

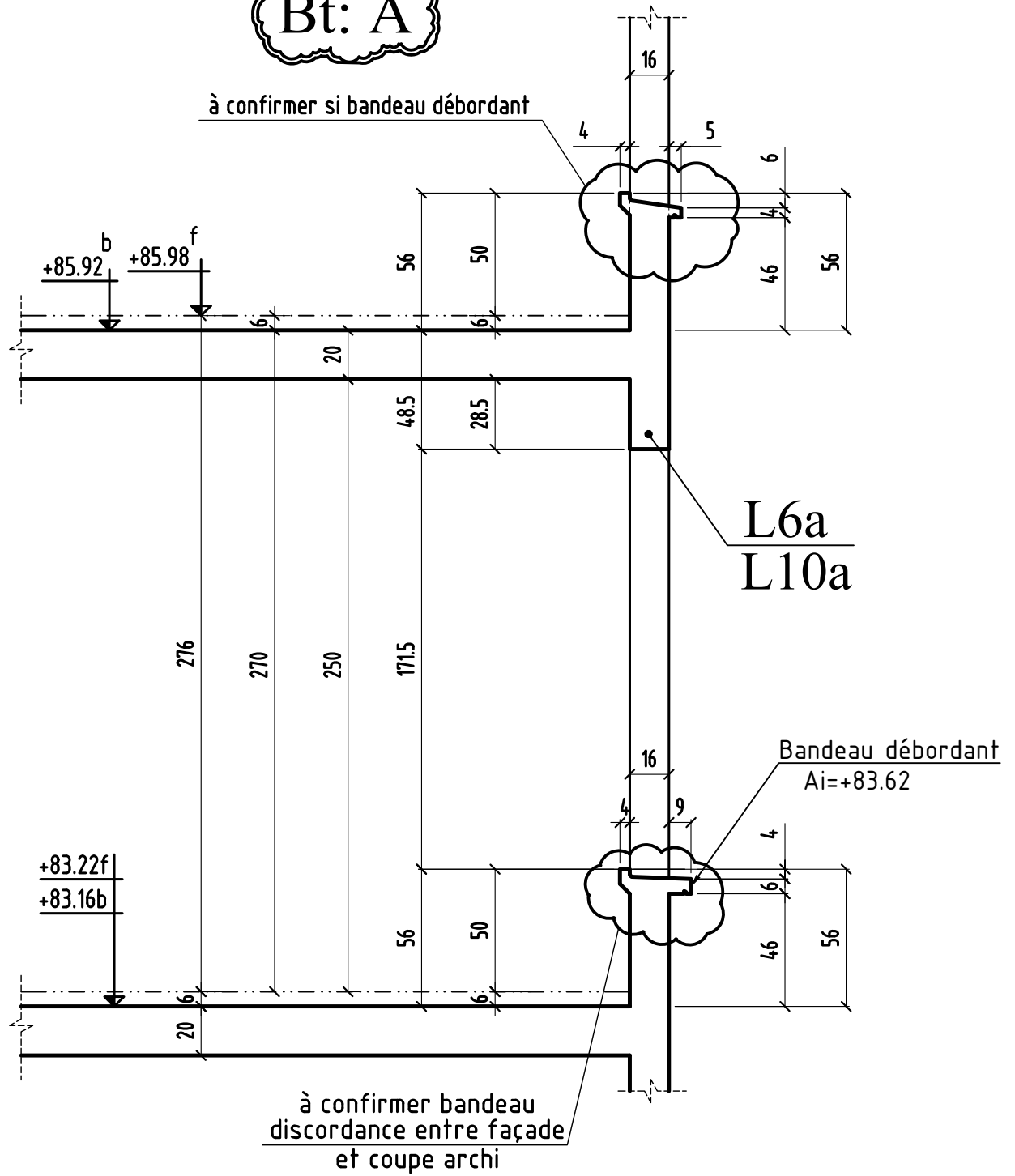



SAINT-LEU-LA FORET

95320

# CONSTRUCTION D'UN ENSEMBLE DE LOGEMENTS COLLECTIF

5 / 7 , Sente du bas troupillard  
17 / 29 , rue gambetta  
4 / 6 , rue guynemer  
département du val d'oise-95320

MAITRE D' OEUVRE	MAITRE D'OUVRAGE
<b>ELLEBOODE architecture</b> 26 RUE berthollet-75005 PARIS ☎: 01.44.34.44.34 ☎: 01.45.04.60.11	<b>SCCV GAMBETTA</b> 38bis,Avenue du général de Gaulle 93110 ROSNY-SOUS BOIS ☎: 01.48.94.51.09 ☎: 01.48.55.64.15
BUREAU DE CONTROLE	<b>ENTREPRISE G.O.</b>
<b>QUALICONSULT</b> 13,rue charles cros 93297 TREMBLAY EN FRANCE ☎: 01.48.19.93.00 ☎: 06.88.50.28.04 mail ; sebastien.cipoire@qualiconsult.fr	<b>M.T.R</b> 9, rue René Cassin 77173 CHEVRY-COSSIGNY ☎: 01.60.62.32.00 ☎: 01.60.62.32.01

PL HAUT 2 etage  
BATIMENT © COUPES (coffrage)

ind.	date	modifications
0	16-07-18	1 ère diffusion.

	DOSSIER		PLAN		APD	
	297 C.28		EXE	IND.	PRO	
				EXE		X
				DOE		
	Ingenieur	Projeteur	Date	Echelle		
	<i>H.B.E</i>	<i>16/07/18</i>	<i>1/25</i>			

COUPE 21 - 21

MODIFICATIONS

A

AFFAIRE: 297  
Ech: 1/25

Cahier C.28  
Page 01

COUPE 21-21

Bt: C

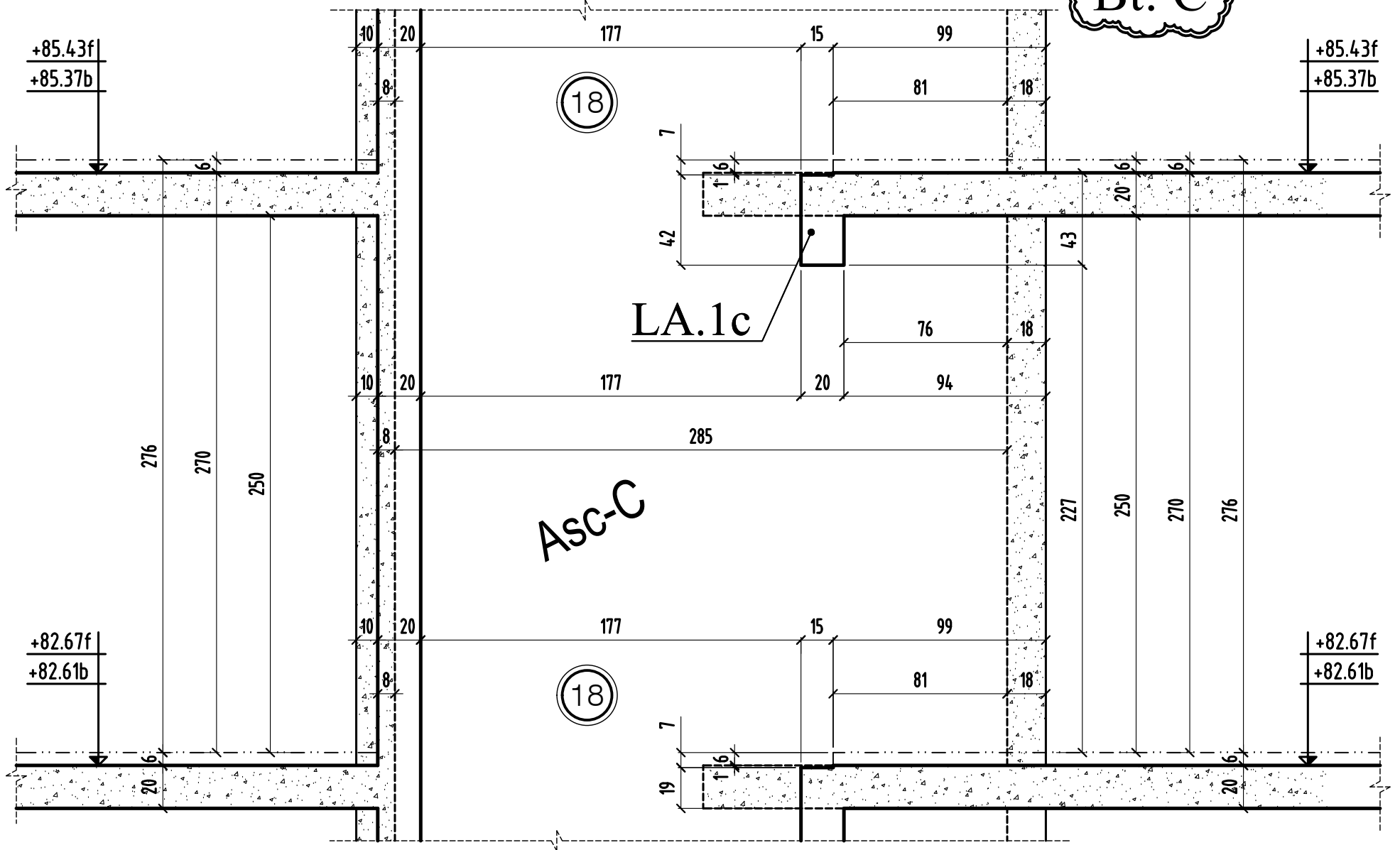

Asc-C

LA.1c

# COUPE 22-22

Bt: C

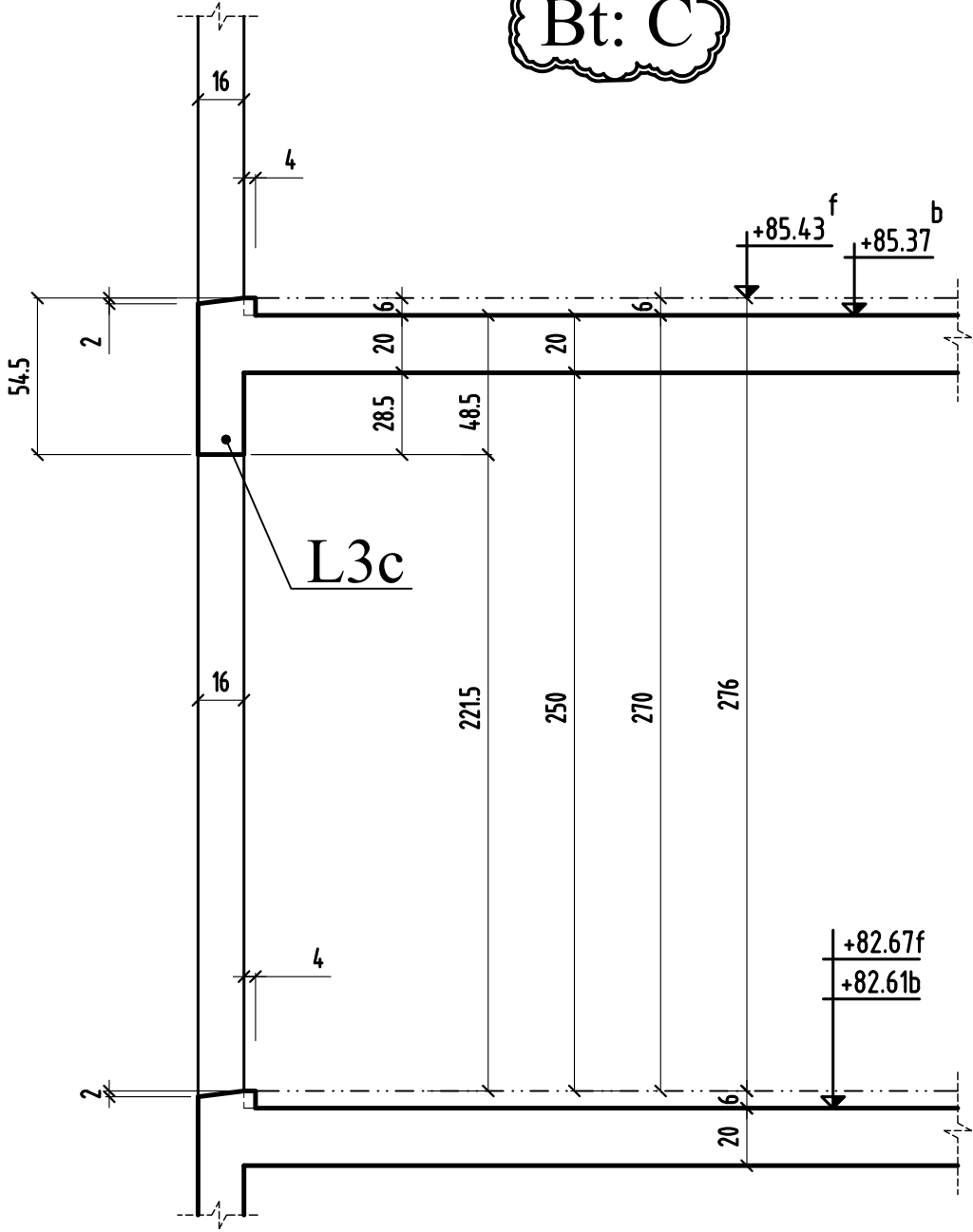

COUPE 22 - 22	MODIFICATIONS	A		AFFAIRE: 297	Cahier C.28
		B		Ech:1/25	Page 02

# COUPE 23-23

Bt: C

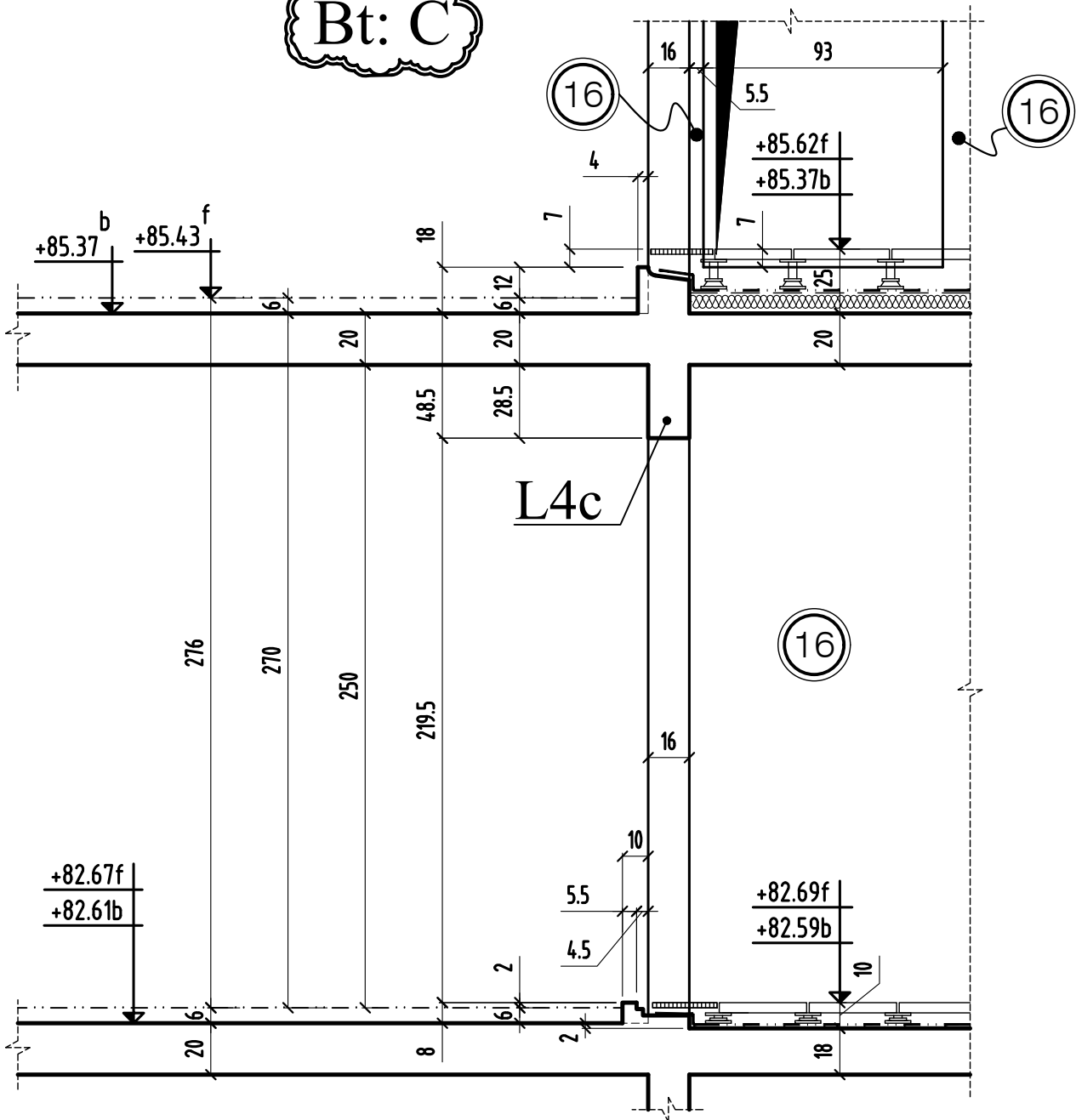

COUPE 23 - 23

MODIFICATIONS  
0

A  
B

AFFAIRE: 297  
Ech: 1/25

Cahier C.28  
Page 03

# COUPE 24-24

Bt: C

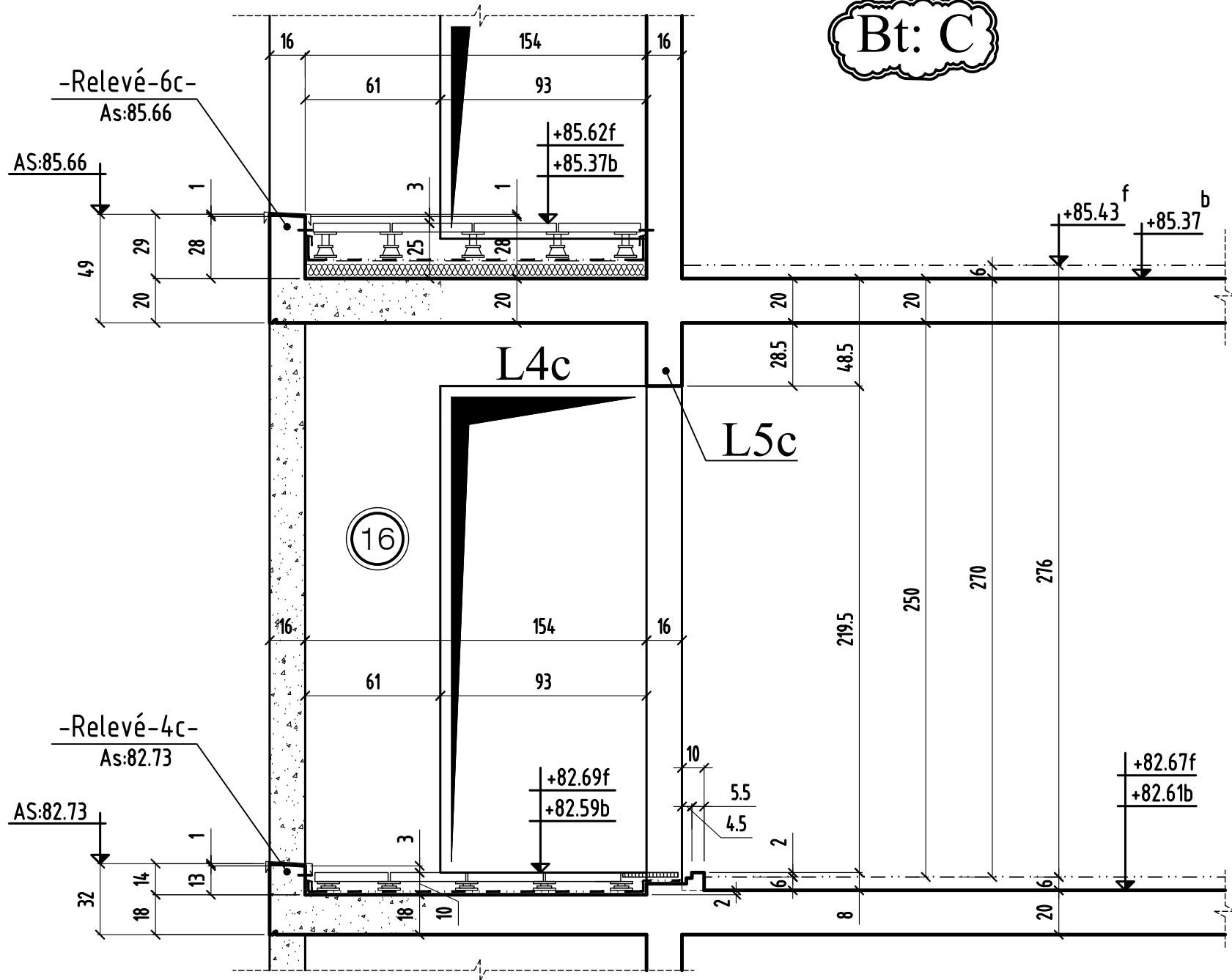

COUPE 24 - 24

MODIFICATIONS  
0

A  
B

AFFAIRE: 297  
Ech: 1/25

Cahier C.28  
Page 04

# COUPE 25-25

Bt: C

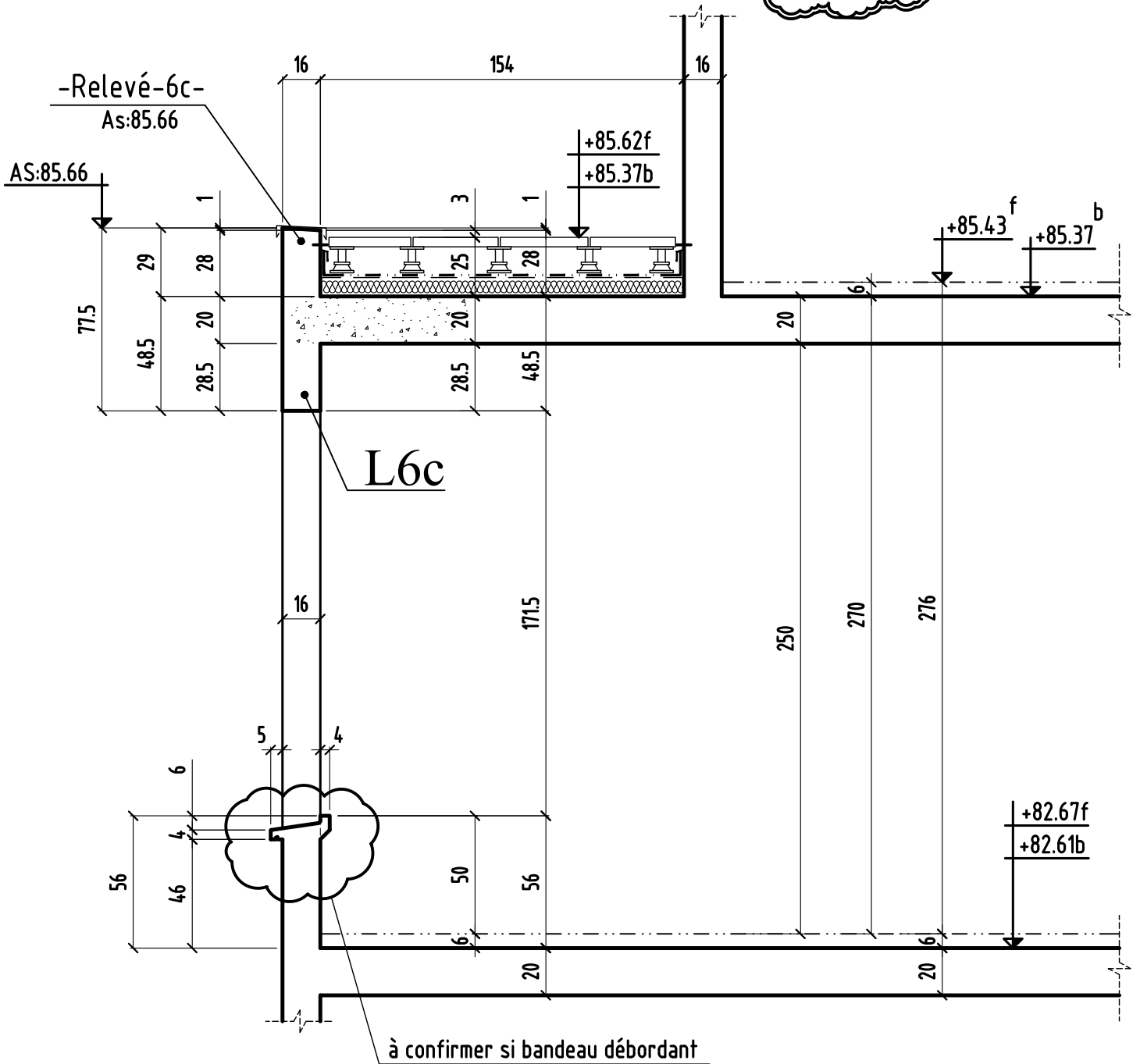







# COUPE 28-28

**Bt: C**

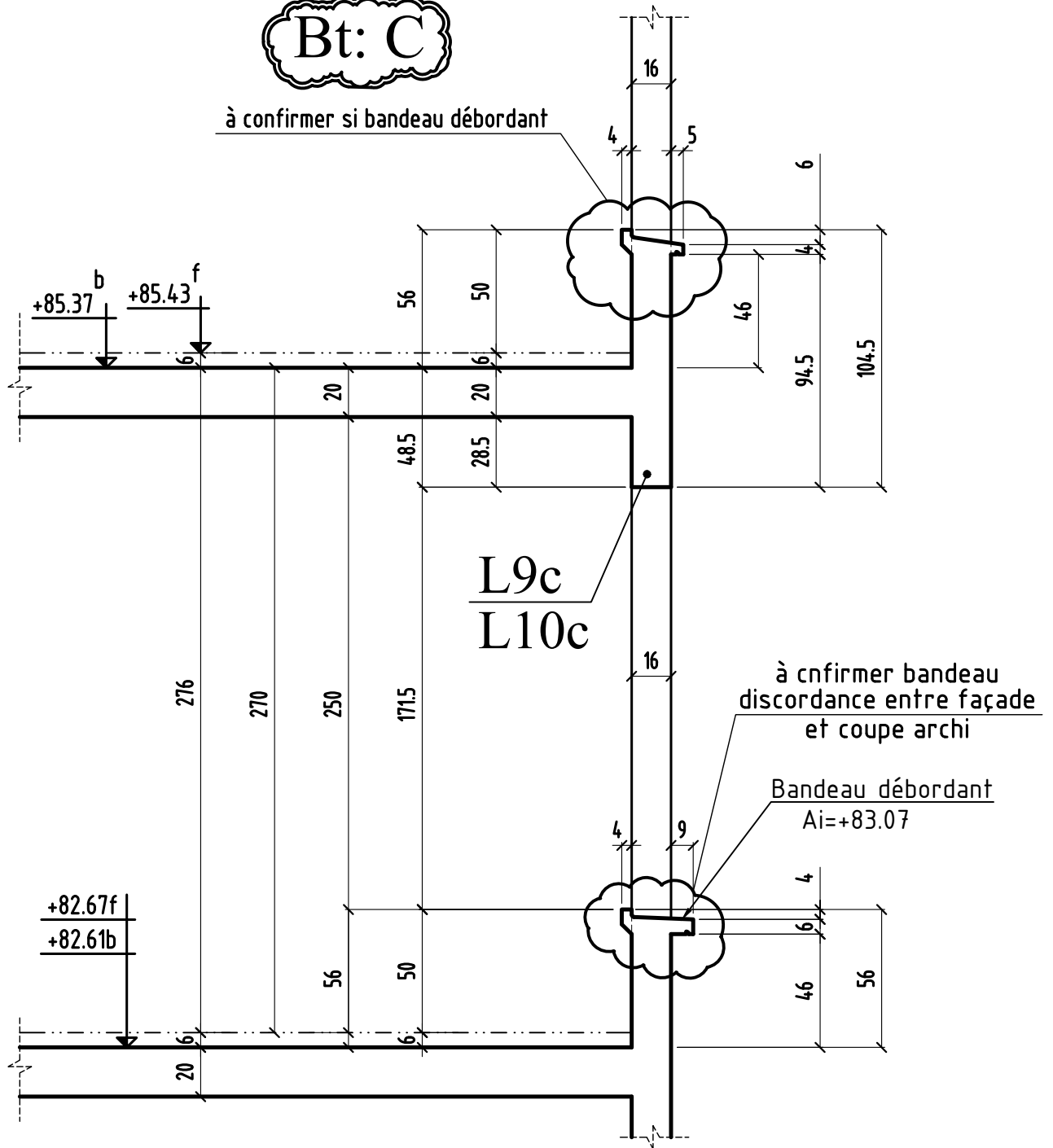

# COUPE 29-29

Bt: C

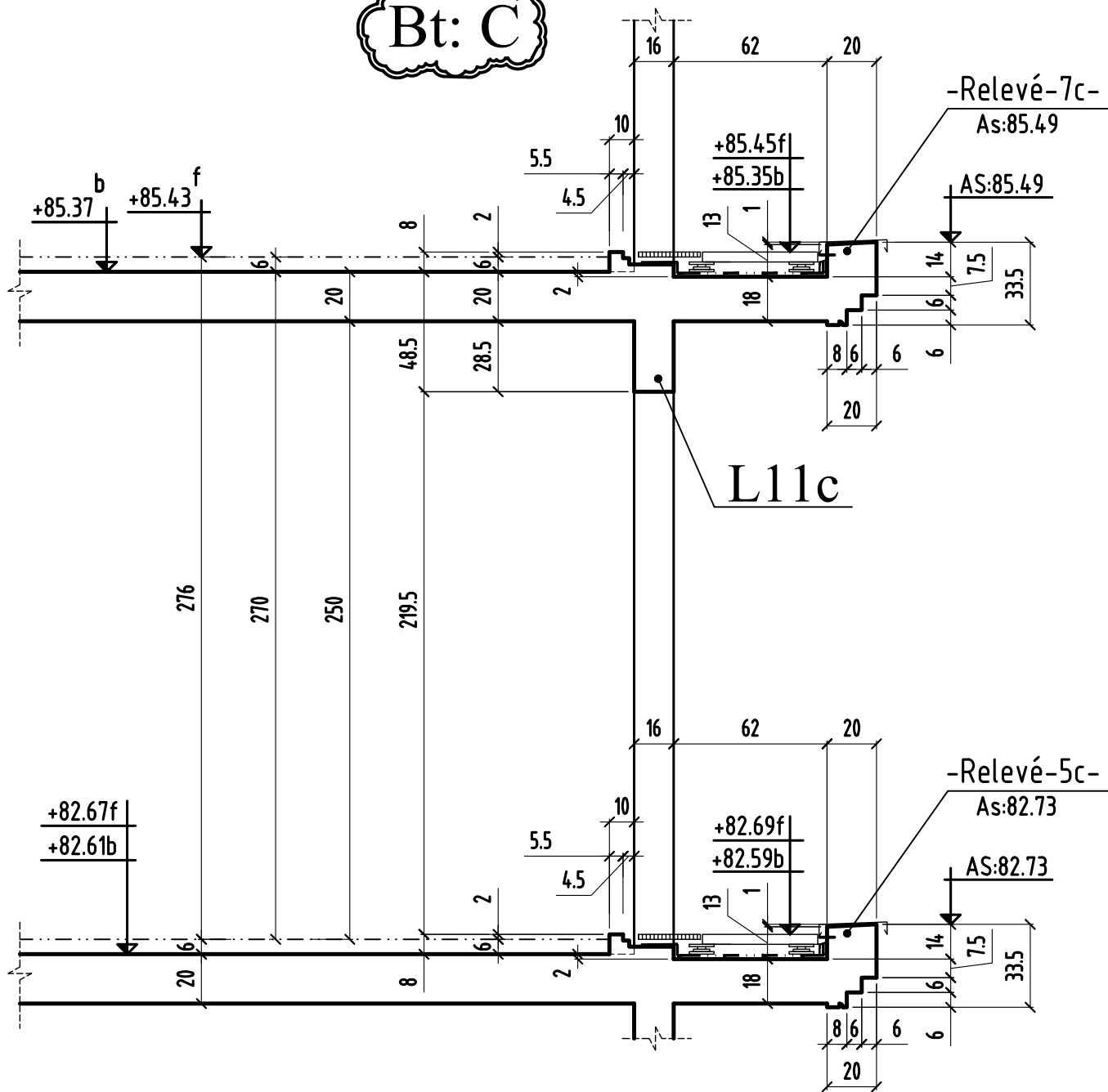

COUPE 29 - 29

MODIFICATIONS

A

AFFAIRE: 297

Cahier C.28

0

B

Ech:1/25

Page 09

# COUPE 30-30

Bt: C

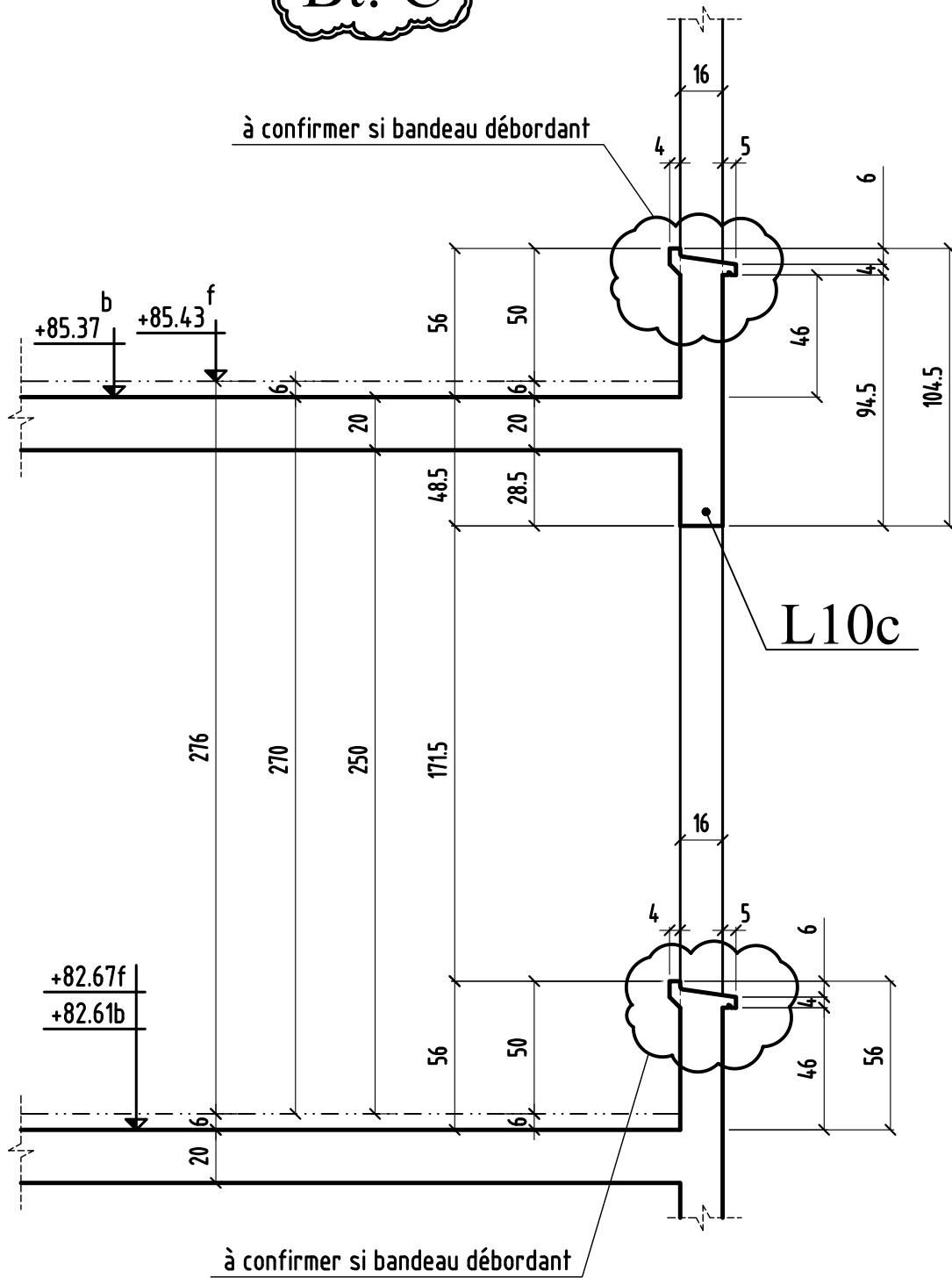



# COUPE 32-32

Bt: C

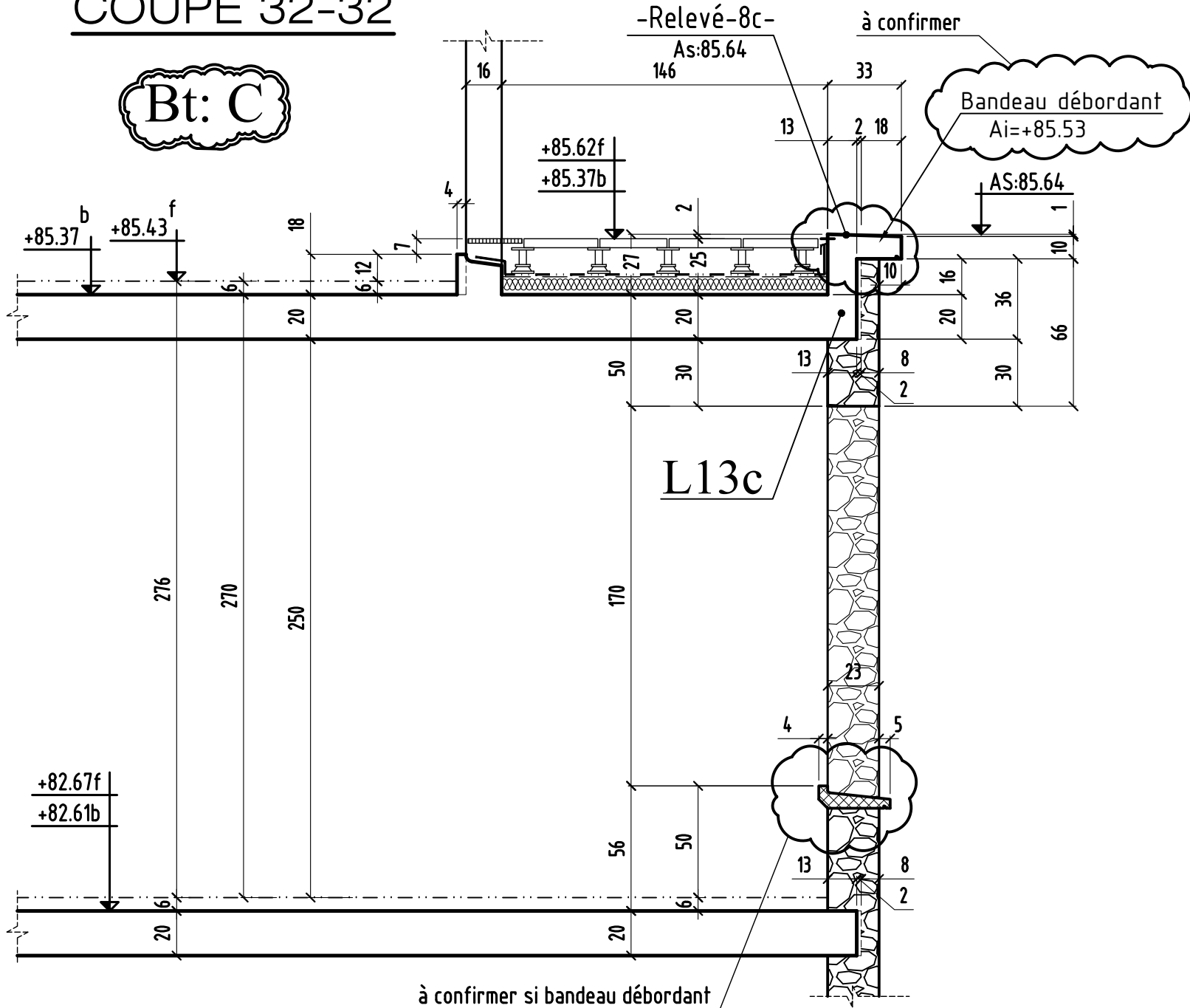

COUPE 32 - 32

MODIFICATIONS  
01

A  
B

AFFAIRE: 297  
Ech: 1/25

Cahier C.28  
Page 12

# COUPE 33-33

Bt: C

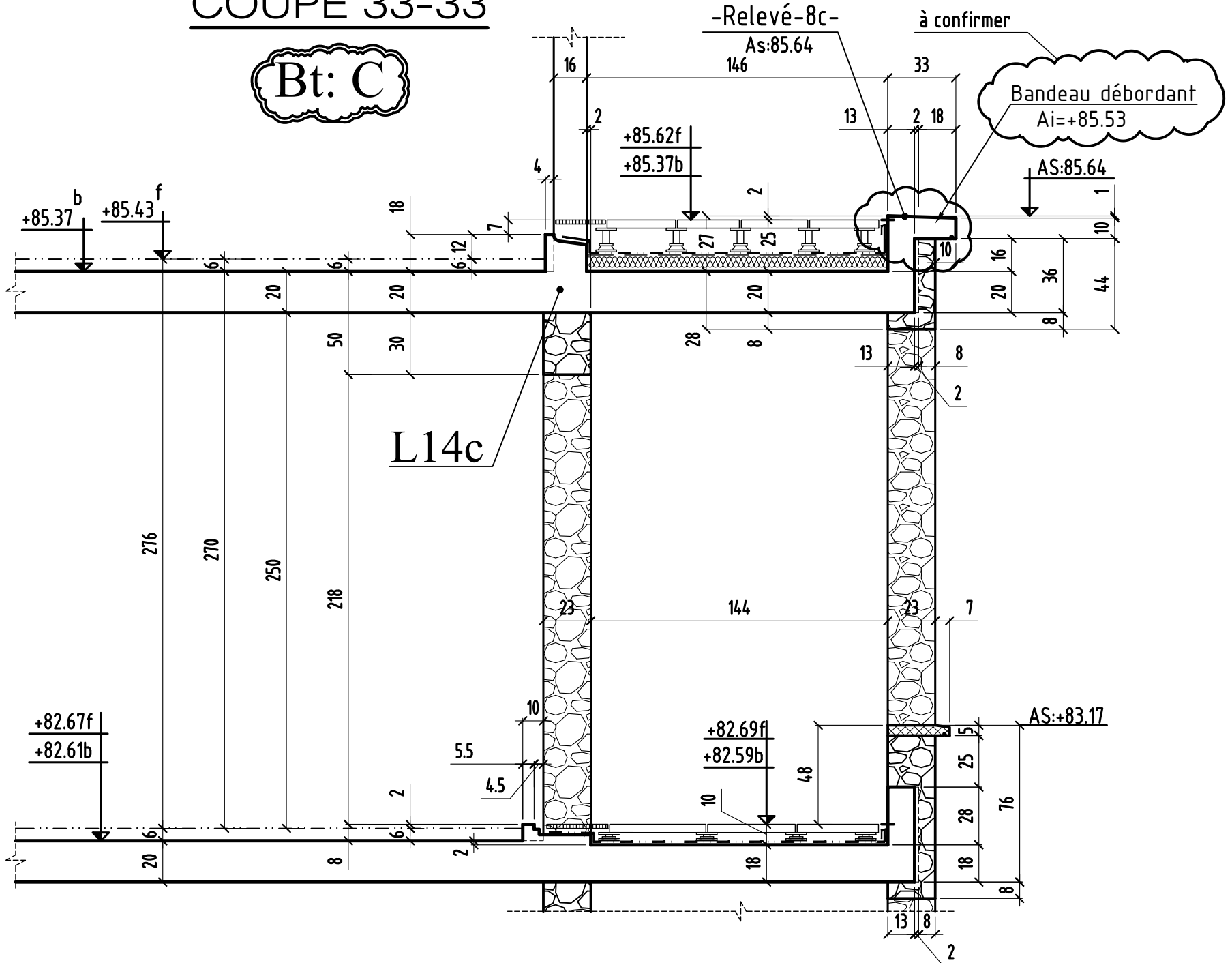

COUPE 33 - 33

MODIFICATIONS  
0

A

AFFAIRE: 297  
Ech: 1/25

Cahier C.28  
Page 13



# COUPE 35-35

Bt: C

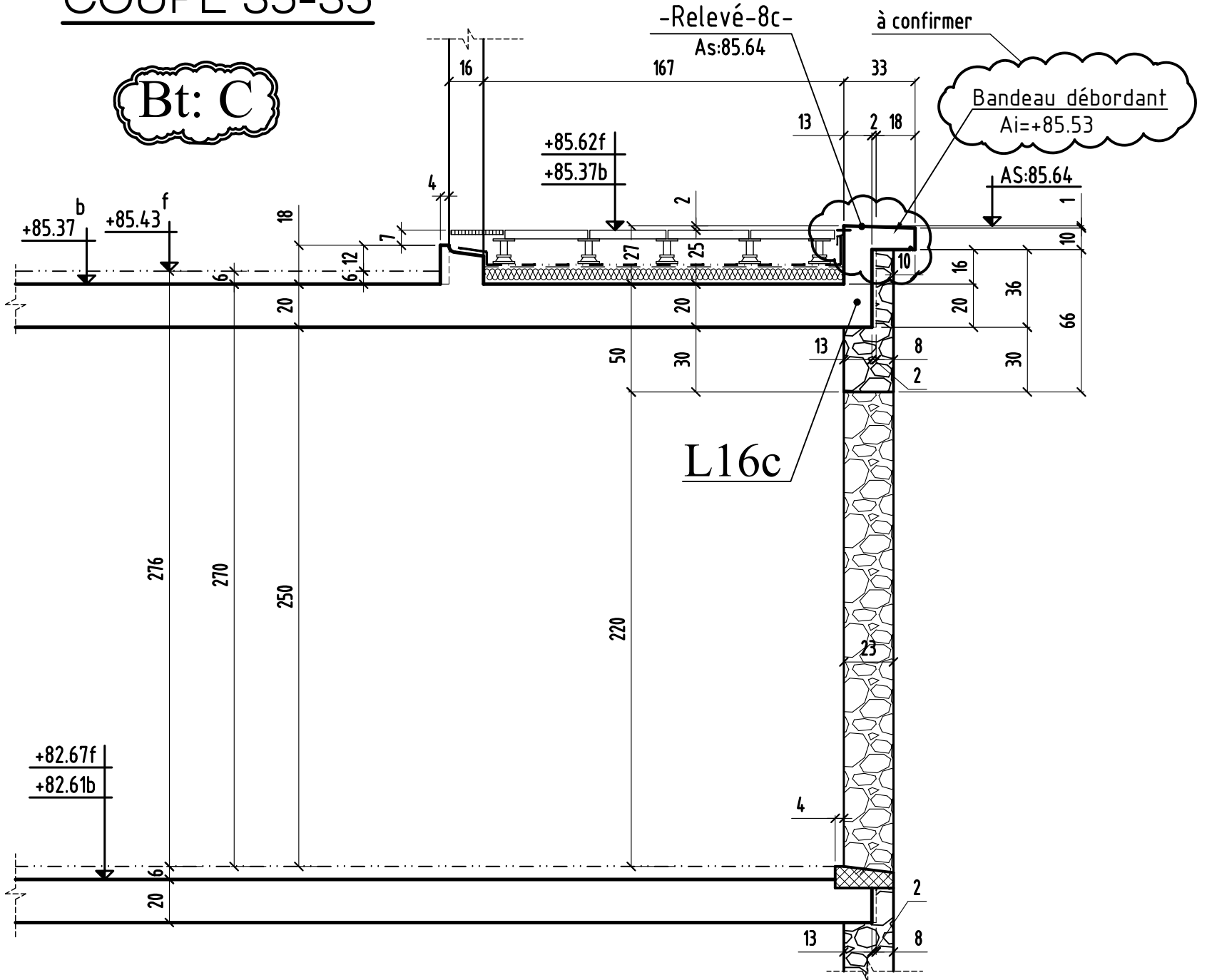

COUPE 35 - 35

MODIFICATIONS  
01

A

B

AFFAIRE: 297  
Ech: 1/25

Cahier C.28  
Page 15





# COUPE 37-37

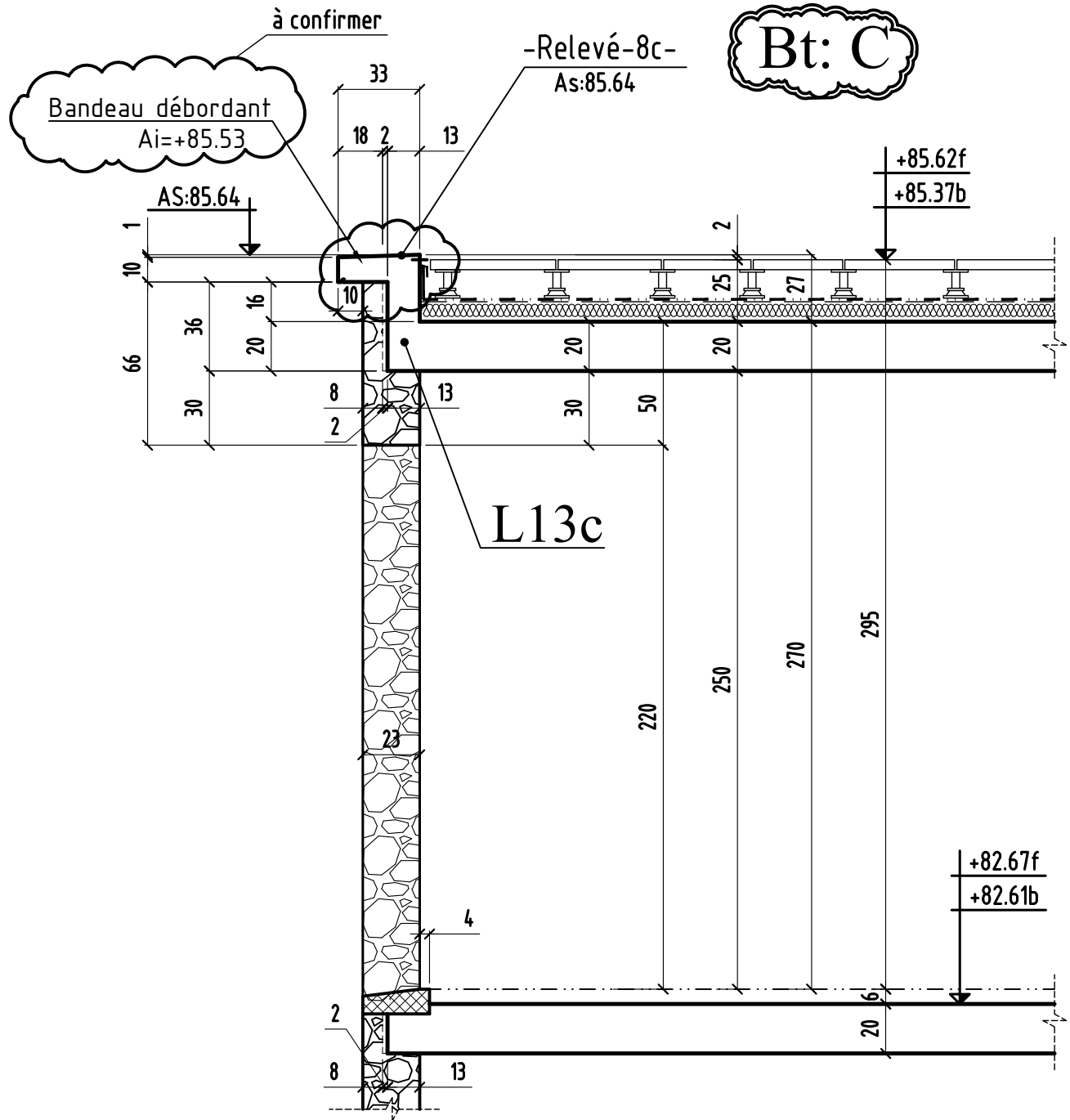





COUPE 40-40

Bt: C

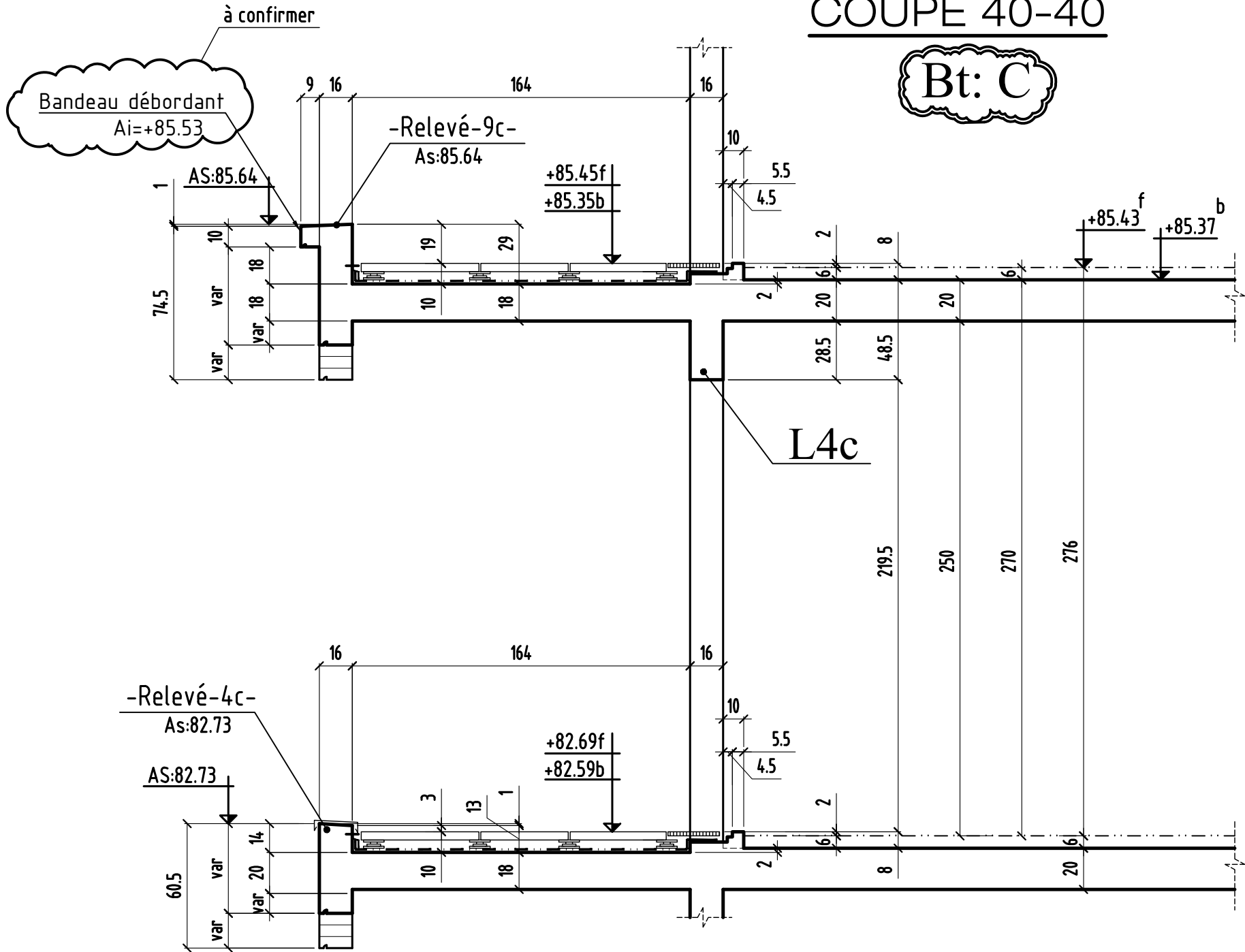

SAINT-LEU-LA FORET

95320

# CONSTRUCTION D'UN ENSEMBLE DE LOGEMENTS COLLECTIF

5 / 7 , Sente du bas troupillard  
17 / 29 , rue gambetta  
4 / 6 , rue guynemer  
département du val d'oise-95320

MAITRE D' OEUVRE	MAITRE D'OUVRAGE
<b>ELLEBOODE architecture</b> 26 RUE berthollet-75005 PARIS ☎: 01.44.34.44.34 ☎: 01.45.04.60.11	<b>SCCV GAMBETTA</b> 38bis,Avenue du général de Gaulle 93110 ROSNY-SOUS BOIS ☎: 01.48.94.51.09 ☎: 01.48.55.64.15
BUREAU DE CONTROLE	<b>ENTREPRISE G.O.</b>
<b>QUALICONSULT</b> 13,rue charles cros 93297 TREMBLAY EN FRANCE ☎: 01.48.19.93.00 ☎: 06.88.50.28.04 mail ; sebastien.cipoire@qualiconsult.fr	<b>M.T.R</b> 9, rue René Cassin 77173 CHEVRY-COSSIGNY ☎: 01.60.62.32.00 ☎: 01.60.62.32.01

PL HAUT 2 étage  
BATIMENTS (D) & (E) COUPES (coffrage)

ind.	date	modifications
0	16-07-18	1 ère diffusion.

	DOSSIER	PLAN		APD	
	297	C.30	EXE	PRO	
				EXE	X
				DOE	
	Ingenieur	Projeteur	Date	Echelle	
	<i>H.B.E</i>	<i>16/07/18</i>	<i>1/25</i>		

# COUPE 1-1

Bt: E

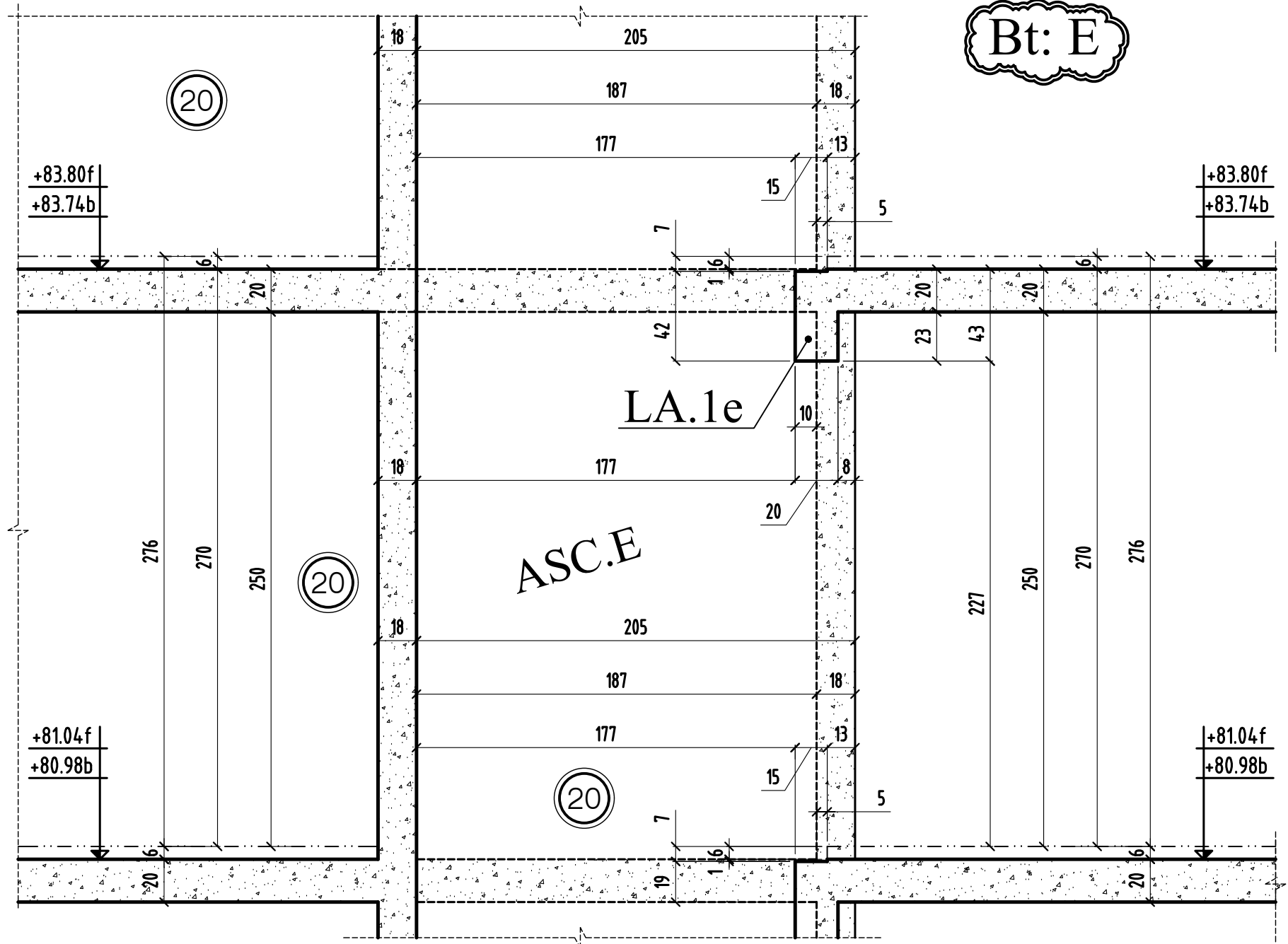

# COUPE 1 - 1

0	MODIFICATIONS	A	AFFAIRE: 297	Cahier C.30
		B	Ech: 1/25	Page 01





# COUPE 3-3

Bt: E

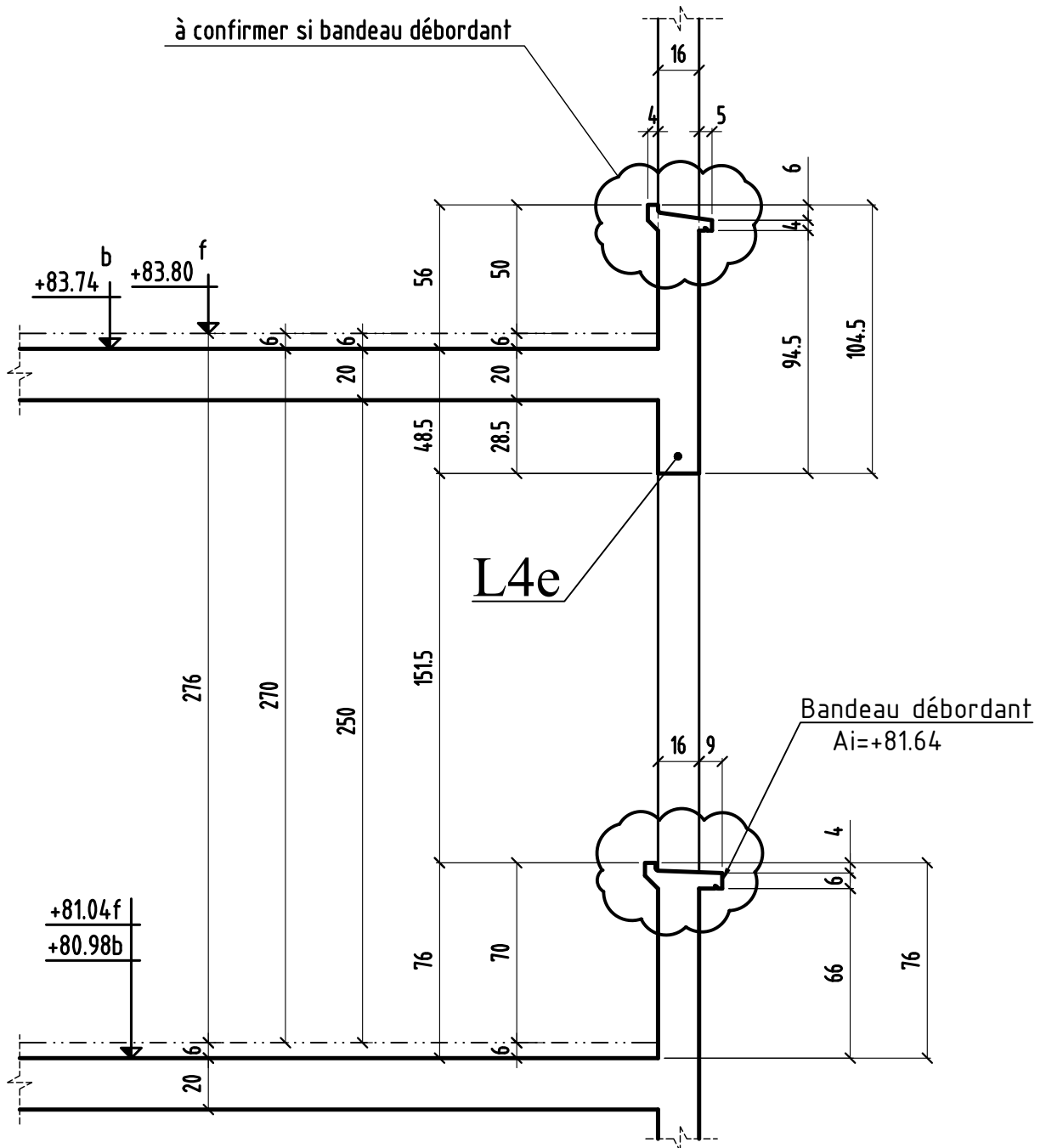



# COUPE 5-5

Bt: E

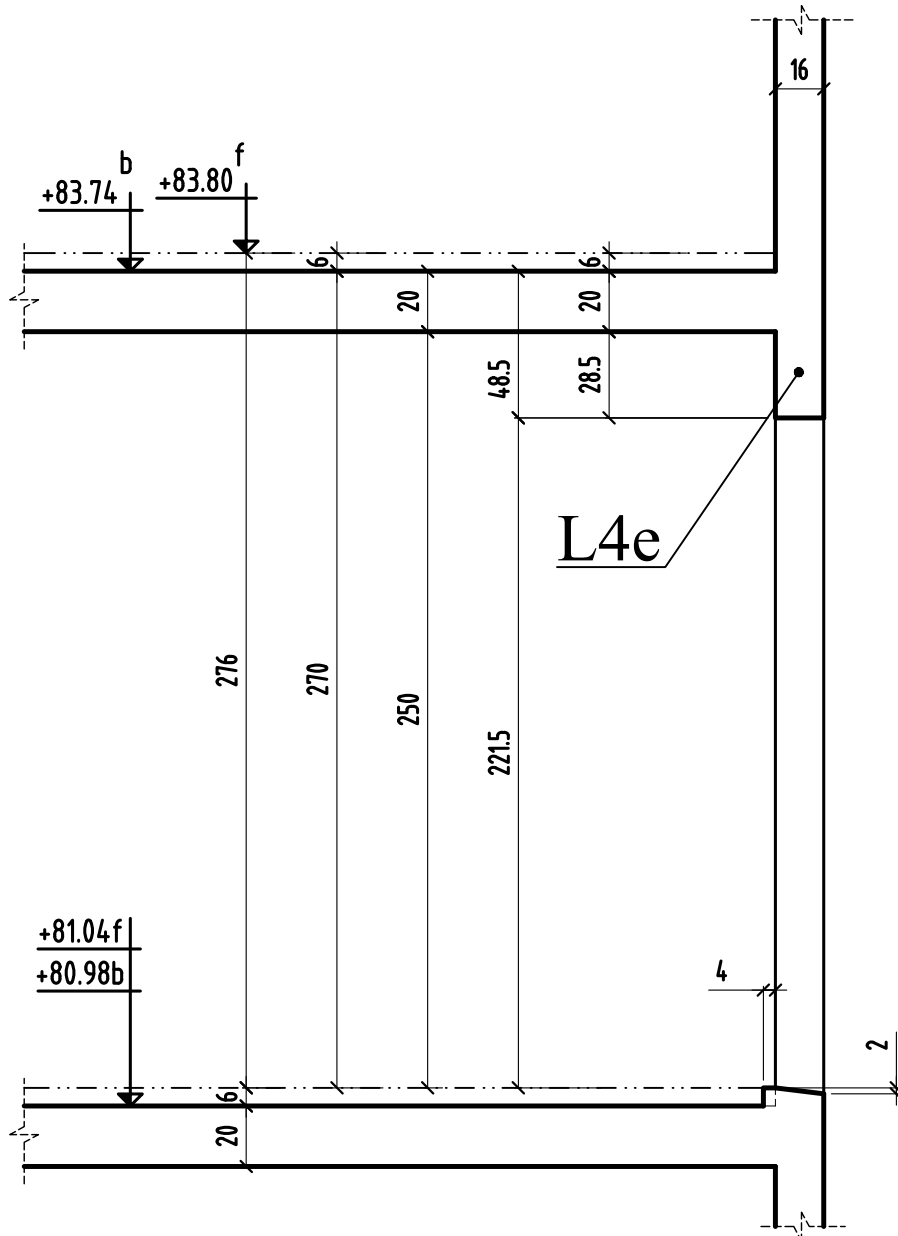

# COUPE 6-6

Bt: E

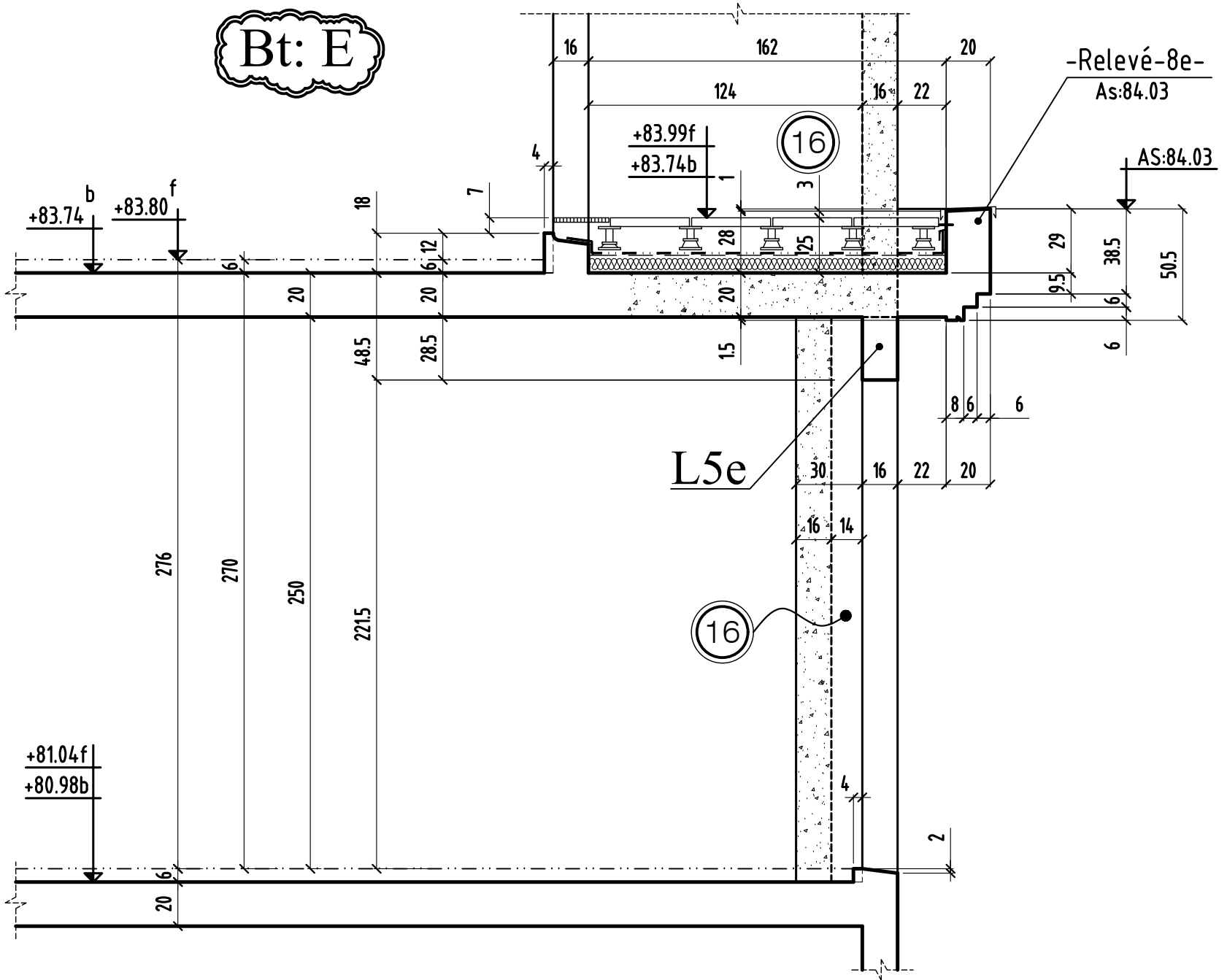

COUPE 5-5

MODIFICATIONS

A

B

AFFAIRE: 297

Ech: 1/25

Cahier C.30

Page 07

# COUPE 7-7

Bt: E

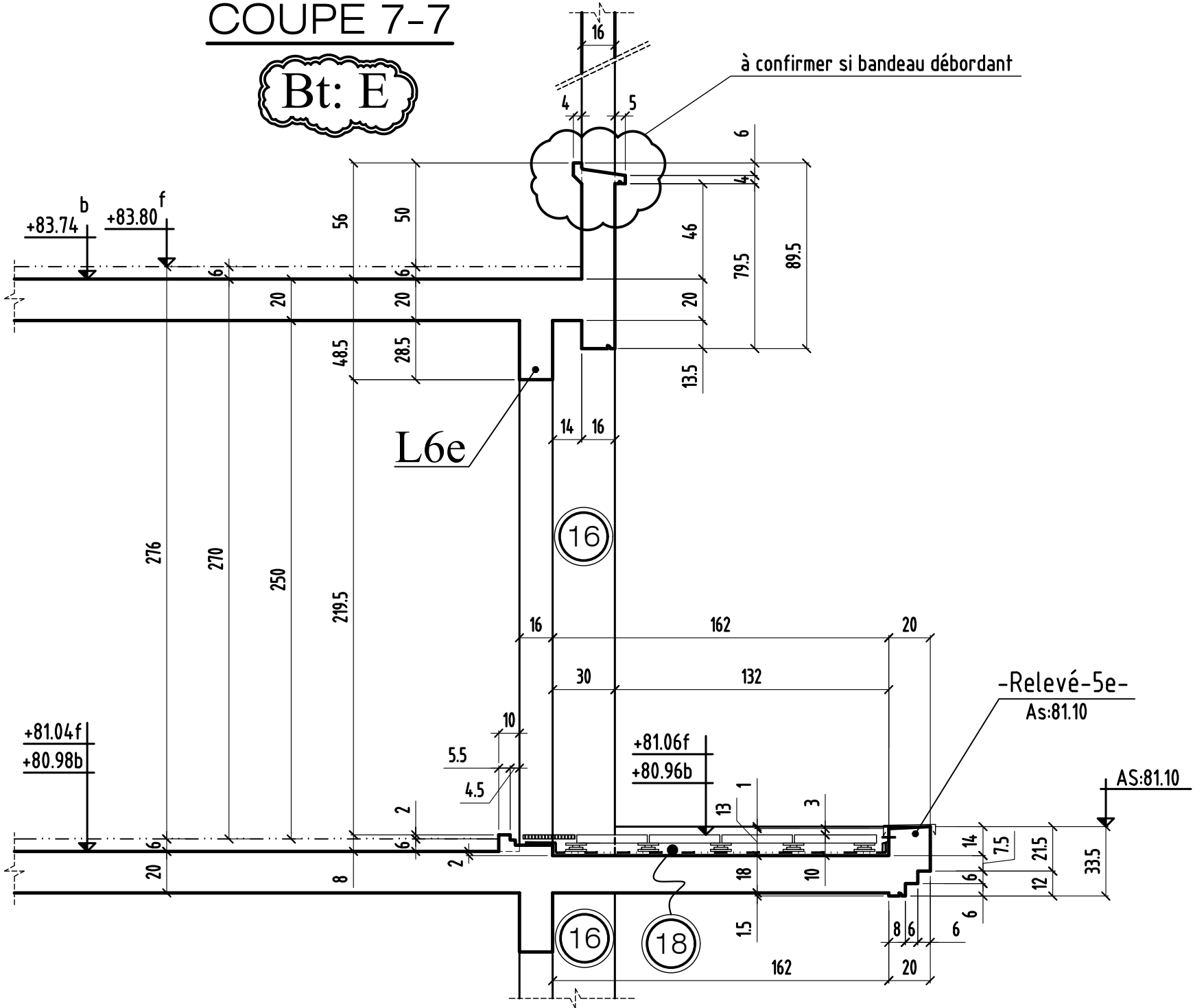

COUPE 7-7

01	MODIFICATIONS	A	AFFAIRE: 297	Cahier C.30
		B	Ech: 1/25	Page 07

# COUPE 8-8

Bt: E

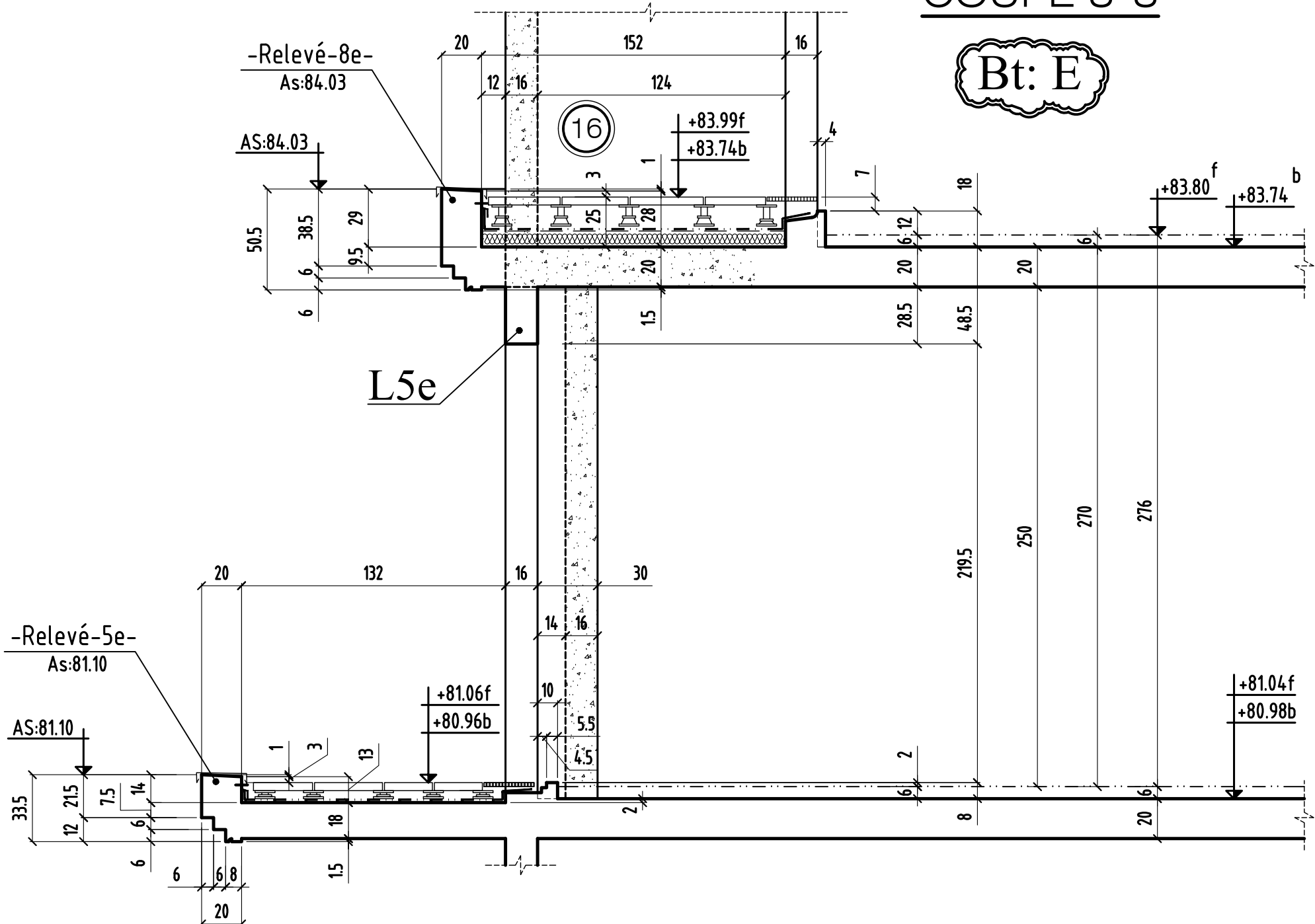

COUPE 8-8

MODIFICATIONS  
0

A  
B

AFFAIRE: 297  
Ech: 1/25

Cahier C.30  
Page 08



COUPE 10-10

COUPE 10-10

Bt: E

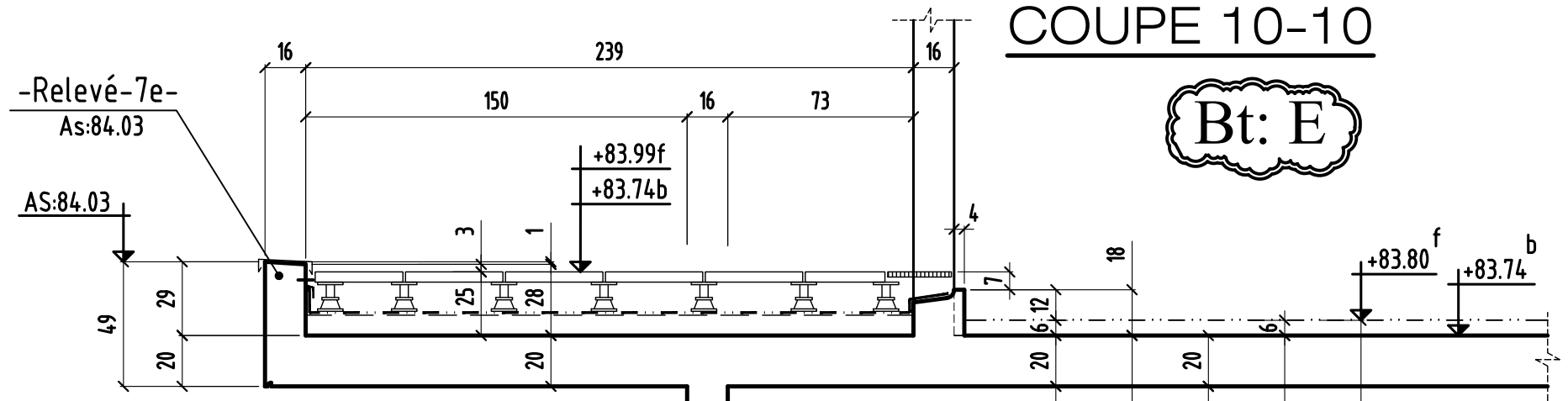

0	MODIFICATIONS	A	AFFAIRE: 297	Cahier C.30
B			Ech: 1/25	Page 10

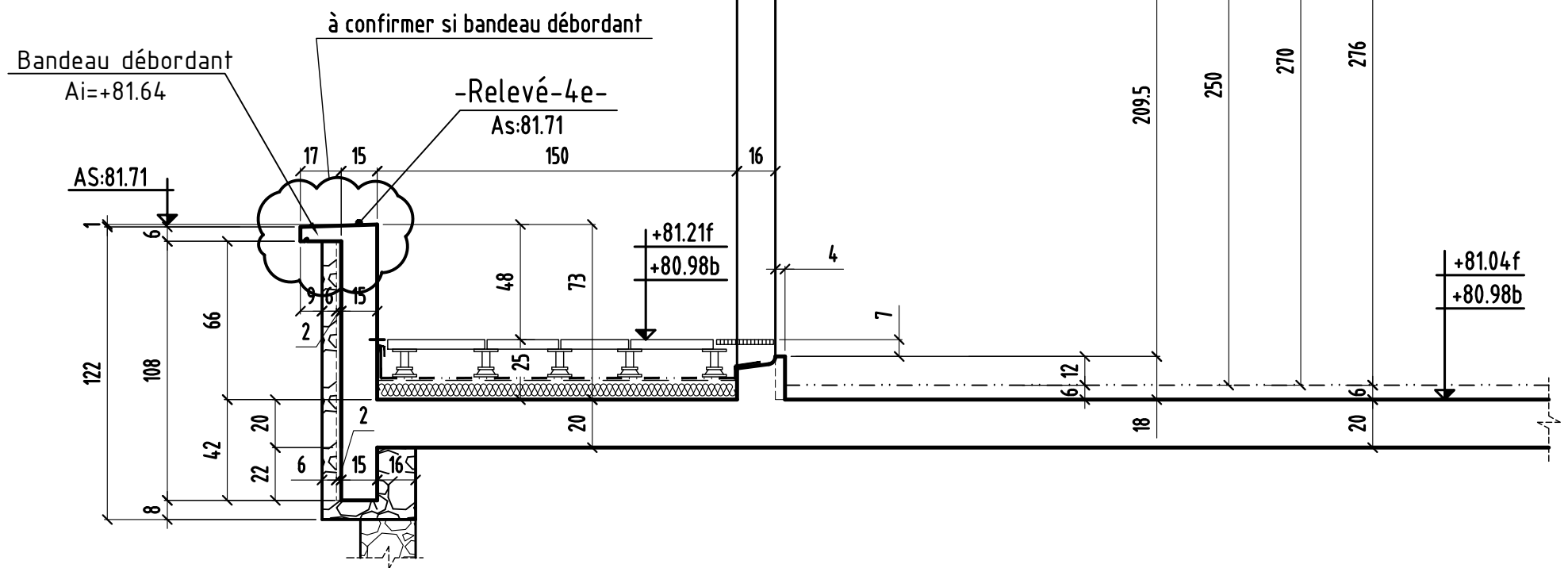



COUPE 11-11

Bt: D

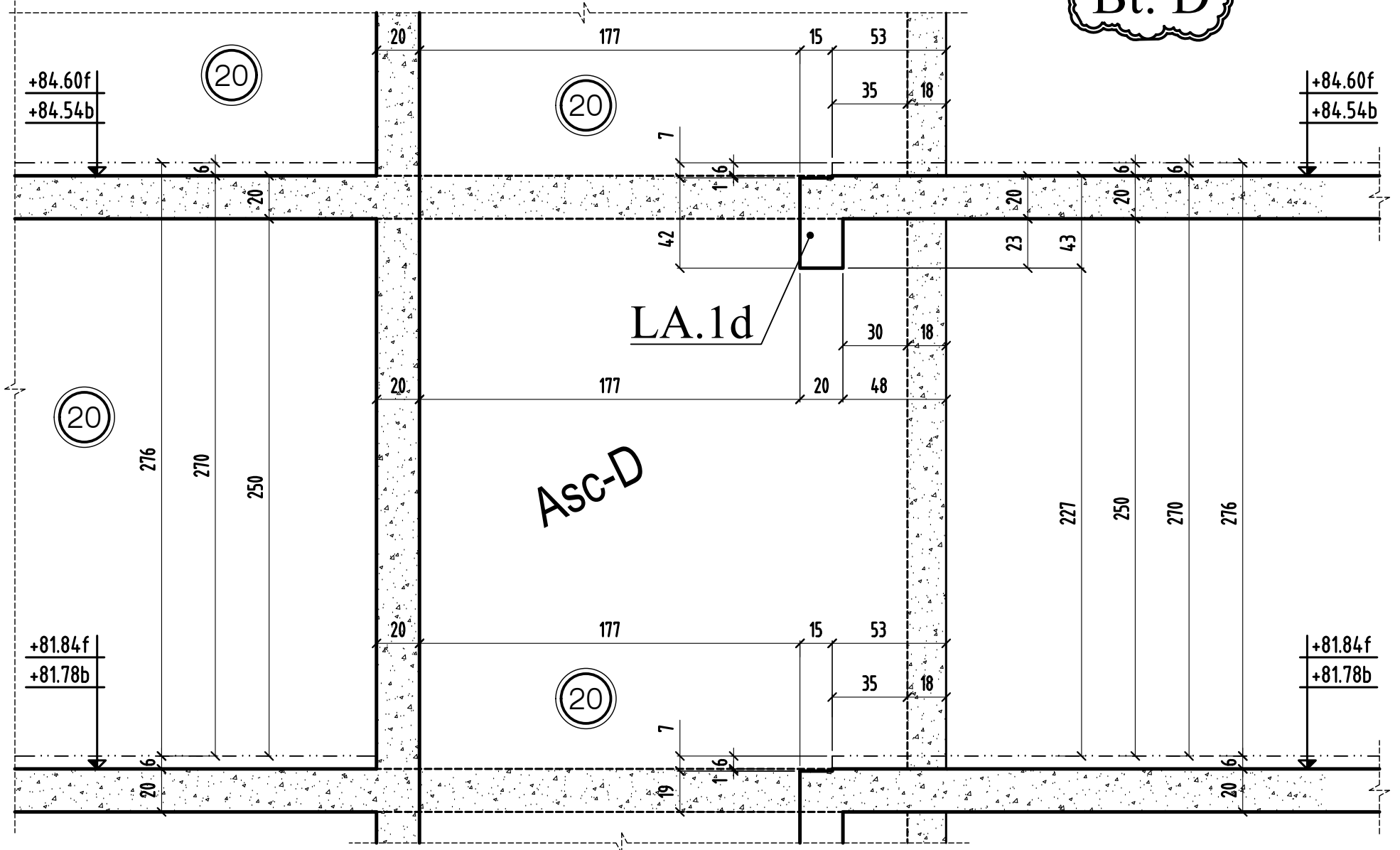

0	MODIFICATIONS
---	---------------

A	
B	

AFFAIRE: 297  
Ech: 1/25



# COUPE 13-13

Bt: D

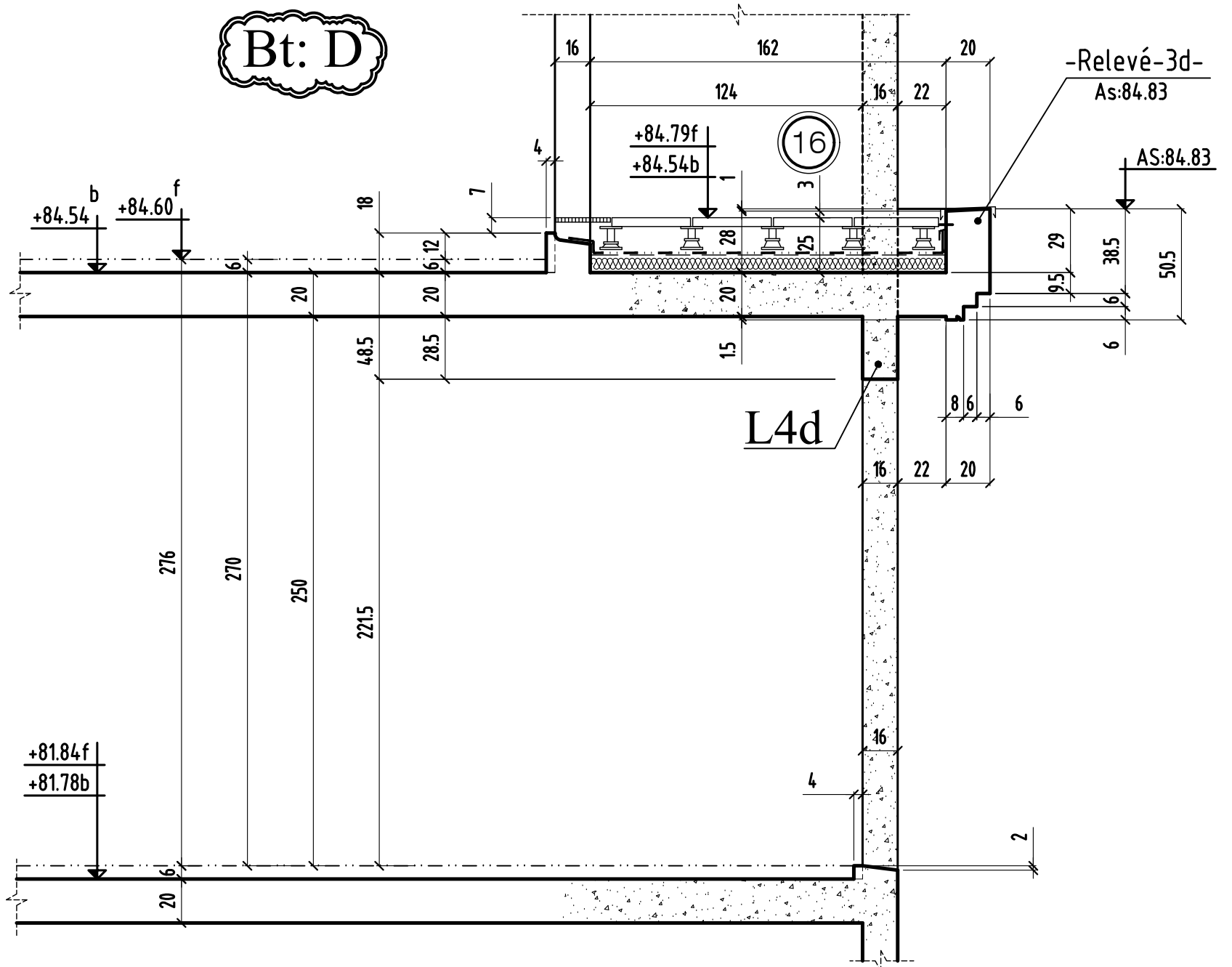

# COUPE 14-14

Bt: D

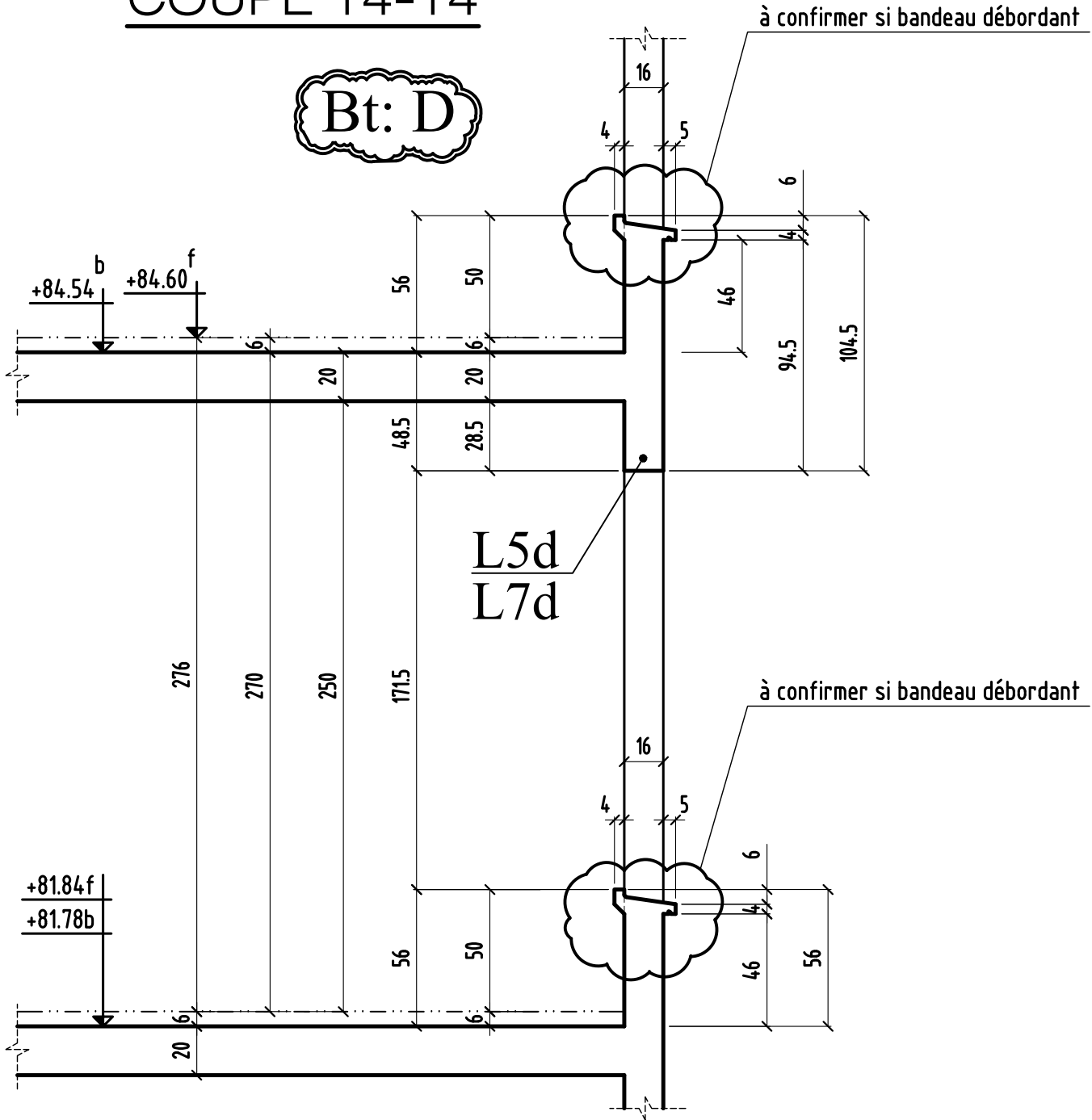

COUPE 14-14

MODIFICATIONS

A

B

AFFAIRE: 297  
Ech: 1/25

Cahier C.30  
Page 14

# COUPE 15-15

Bt: D

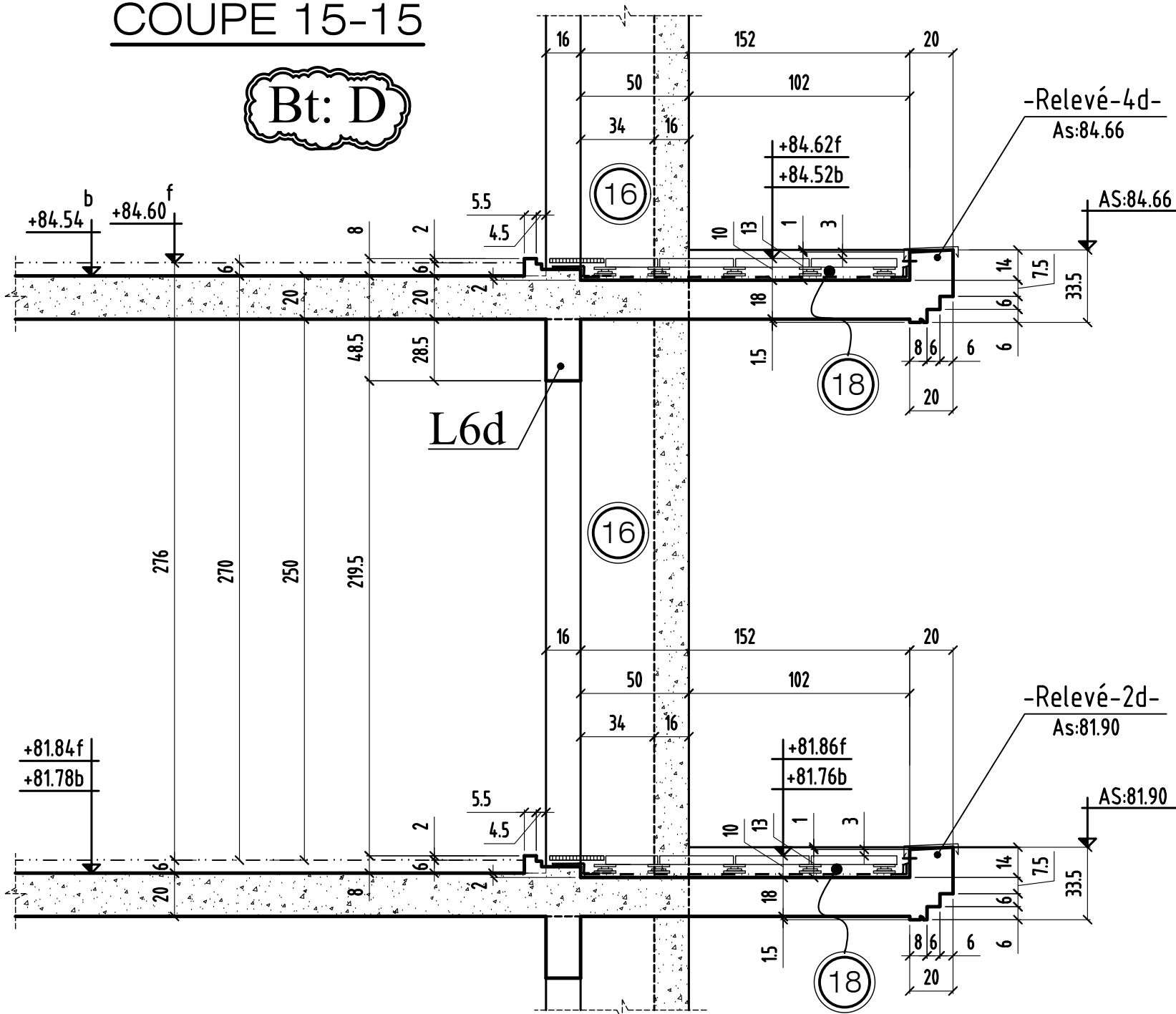

COUPE 15-15

0	MODIFICATIONS	A	AFFAIRE: 297	Cahier C.30
		B	Ech: 1/25	Page 15

# COUPE 16-16

Bt: D

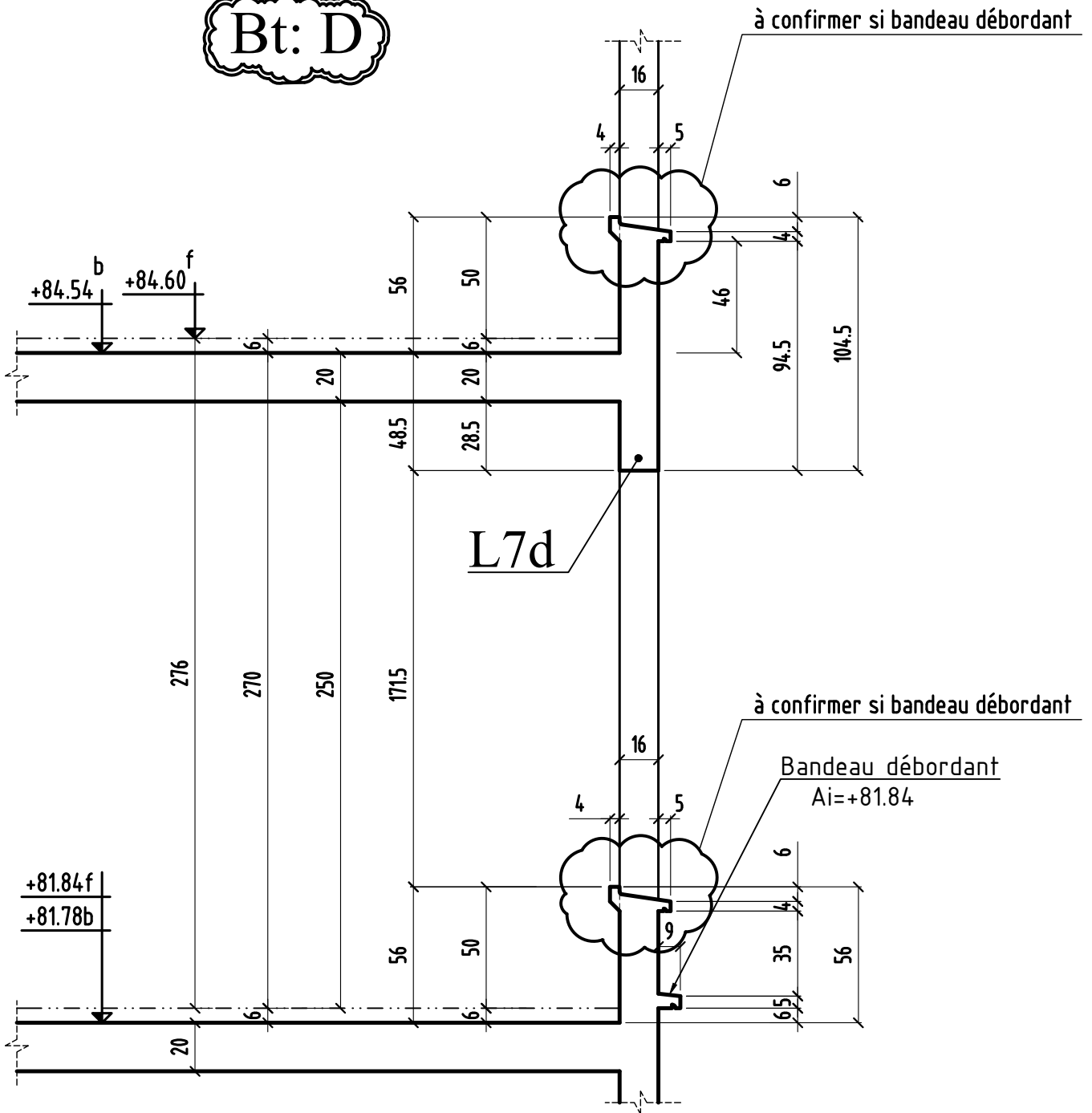

# COUPE 17-17

Bt: D

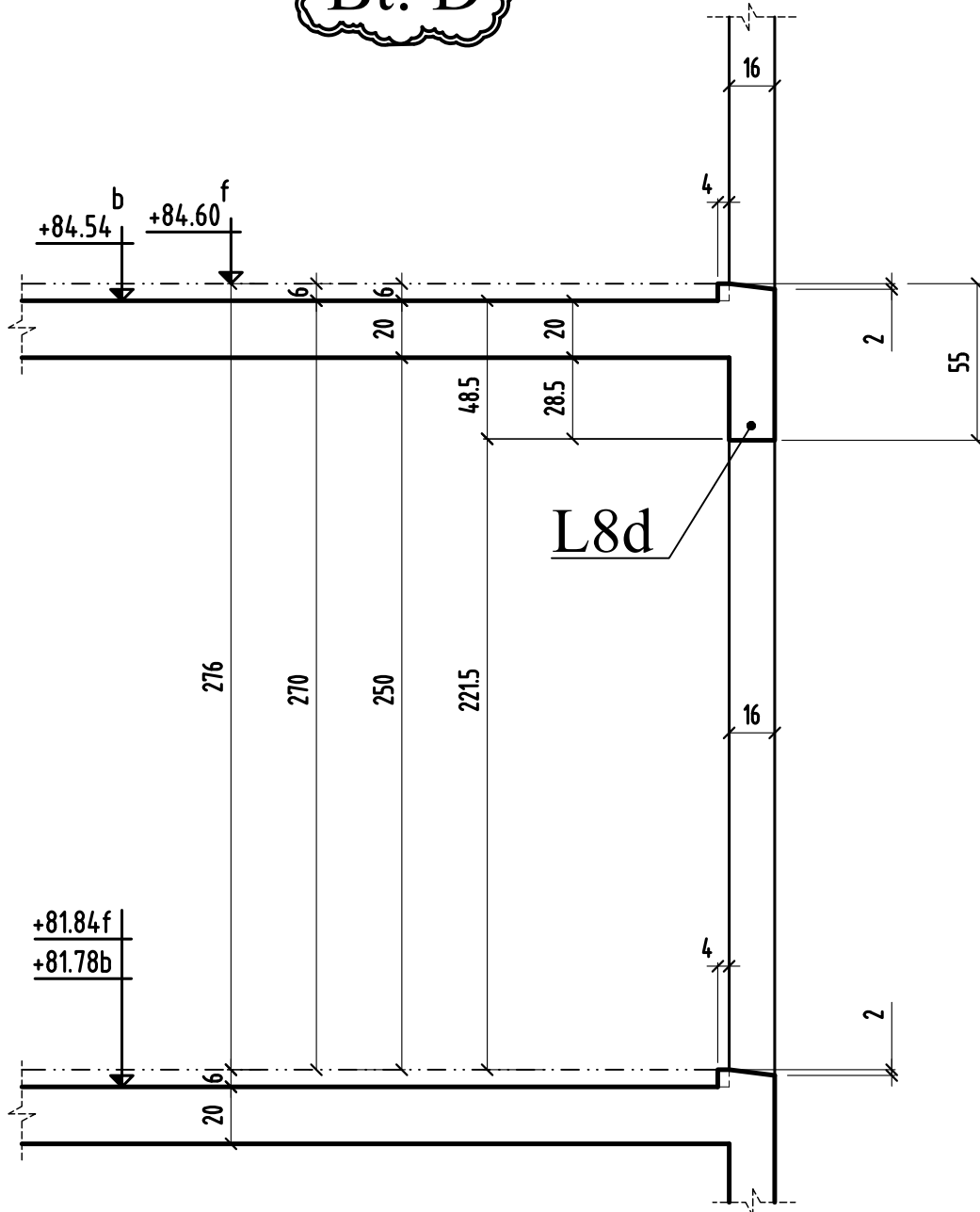

# COUPE 18-18

Bt: D

à confirmer si bandeau débordant

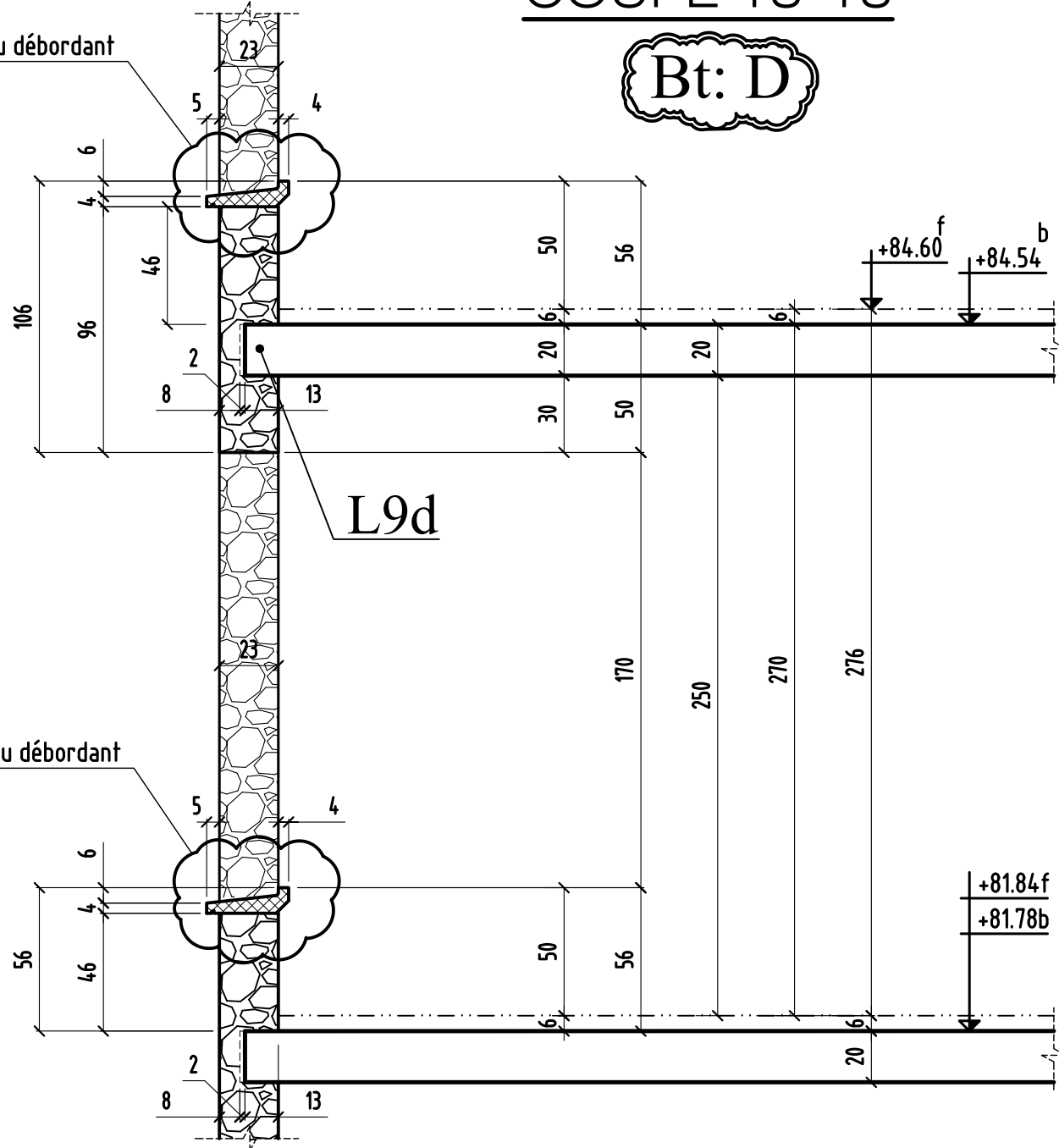

à confirmer si bandeau débordant

COUPE 18 - 18

MODIFICATIONS  
01

A  
B

AFFAIRE: 297  
Ech: 1/25

Cahier C.30  
Page 18





