

N°	AI	TYPE	Dim(cm) hxt ou ø
Y	4,2,3	EL	ø5
Z	4,2,1	EL	ø5
a	4,2,3	EL	ø5

N°	AI	TYPE	Dim(cm) hxt ou ø
50	4,2,30	PB	20x20h

N°	AI	TYPE	Dim(cm) hxt ou ø
1	4,1,5	PB	30x30h
2	4,2,3	PB	30x30h
3	4,1,5	PB	60x35h
4	4,1,5	PB	50x30h
5	4,1,5	PB	30x35h
6	4,1,5	PB	90x30h
7	4,2,10	EL	20x20h
8	4,2,10	EL	30x20h
9	4,2,27	PB	20x20h
10	4,2,24	PB	30x30h
11	4,2,26	PB	30x30h
12	4,2,23	EL	50x20h

Nota : suppression P14 & P15  
en attente détail 13.8

N°	AI	TYPE	Dim(cm) hxt ou ø
A	4,2,10	PB	ø17,5
B	4,2,05	PB	ø14
C	4,2,20	PB	ø14
D	4,2,23	PB	ø17,5
E	4,2,16	PB	ø14
F	4,2,08	PB	ø17,5
G	4,2,09	PB	ø17,5
H	4,2,17	PB	ø17,5
I	4,2,05	PB	ø17,5
J	4,2,08	PB	ø14
K	4,2,14	PB	ø14
L	4,2,18	PB	ø14
M	4,2,21	PB	ø17,5
N	4,2,10	EL	ø10
O	4,2,11	PB	ø14
P	4,2,23	PB	ø17,5
Q	4,2,26	PB	ø17,5
R	4,2,24	PB	ø17,5
S	4,2,16	PB	ø17,5
T	4,2,29	PB	ø17,5
U	4,2,28	PB	ø17,5
V	4,2,07	PB	ø17,5
W	4,2,12	PB	ø17,5
X	4,2,33	EL	ø10

VOIR PLAN N° : CO-31 - COUPES ET DETAILS

**Charges et surcharges :**

**Logements :**  
chape e=14cm

G : = PP+200 kg/m2 Q : = 150 kg/m2

Local poussettes - vélos, circulations Hall :

G : = PP+120 kg/m2 Q : = 250 kg/m2

Terrasses avec dalles sur plots :

G : = PP+100 kg/m2 Q : = 250 kg/m2

Dalle végétalisée inaccessibles :

G : = PP+300 kg/m2 Q : = 150 kg/m2

Cheminement d'accès au Häll :

G : = PP+300 kg/m2 Q : = 250 kg/m2

(sauf zone avec G=PP+1,17/m<sup>2</sup>)

Rampe :

G : = PP Q : = 250 kg/m2

Dalle au-dessus de la rampe :

G : = PP+500 kg/m2 Q : = 150 kg/m2

**Construction de 91 logements**

Avenue Chaumont  
Saint-Ouen launâtre

**Coffrage PHSS-1 CO-03 B**

DATE		NUMERO	
NOM	DATE	MODIFICATION	COULÉ
A	2022-05-20	MISE A JOUR STATUT FINANCIER ET FORTIFICATION ET DETAILS	EL
B	18-10-2024	MISE A JOUR STATUT FINANCIER ET FORTIFICATION	RJ
SMC ALVAREZ COFFRAGES 6 Rue de la République - 75001 PARIS - 01 57 26 26 26 01 57 26 26 26 01 57 26 26 26 01 57 26 26 26			SMC ALVAREZ COFFRAGES 01 57 26 26 26 01 57 26 26 26 01 57 26 26 26

# Construction de 91 logements

Avenue Chauvin

Saint-Ouen l'aumône

---

PLAN : TYPE : NUMERO : INDICE :  
**COFFRAGE : COUPES ET DETAILS PHSS-1 CO-31 B**

---

HYPOTHESES DE L'ETUDE

REPERAGE DE CHARGES:

INDICE	DATE	MODIFICATIONS	CALCUL	COFFRAGE
Ø	12.06.2019	PREMIERE DIFFUSION	R.J	H.M
A	23.07.2019	MODIF COUPE 8-8 & MISE A JOUR SUIVANT VISA 27	R.J	H.M
B	10.10.2019	MISE A JOUR SUIVANT MINUISERIE ( RDC ) ET VISA 27A	R.J	H.M

---

MAITRE D'OUVRAGE	SNC ALTAREA COGEDIM IDF	8, Avenue Delcassé - 75008 PARIS - Tél: 01.56.26.24.00
ARCHITECTE	ARCHIKUBIK	Calle Luis Antunez 6 - 08006 BARCELONA - TEL : +34.93.415.27.62
BUREAU DE CONTROLE	VERITAS	5, Boulevard Pourtout - 92563 RUEIL MALMAISON - Tél: 01.47.52.45.69
ENTREPRISE GROS OEUVRE	CFPB	10, Rue des Vieilles Vignes - 77183 CROISSY BEAUBOURG - Tél: 01.60.37.01.36

# COUPE 1-1

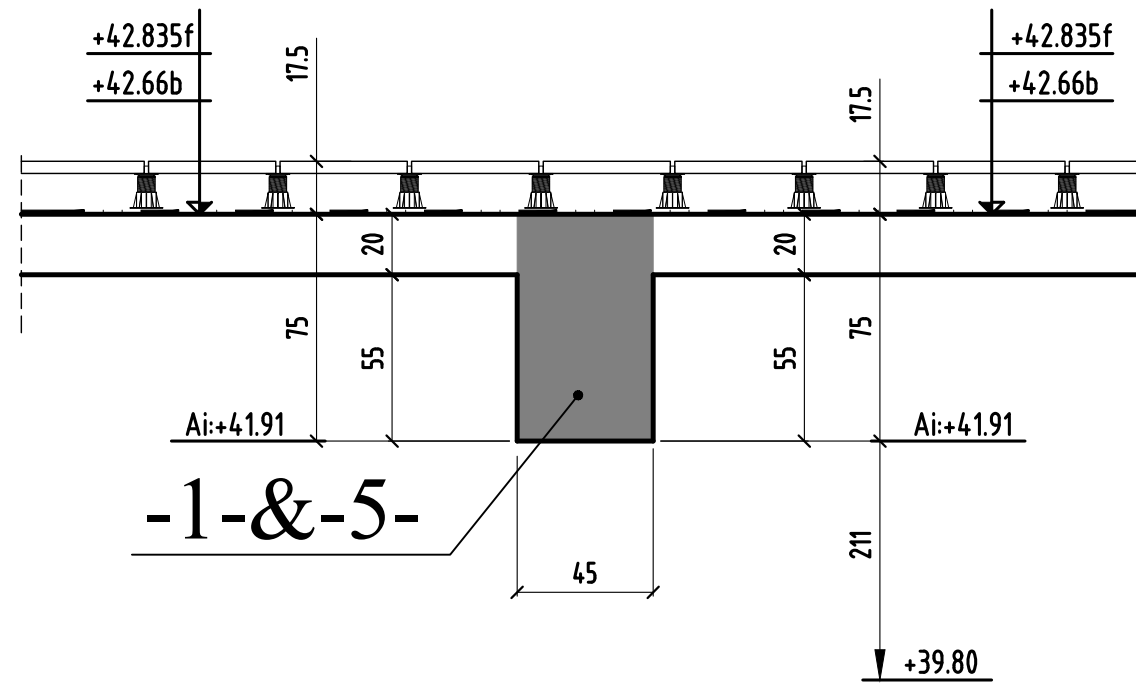

# COUPE 2-2

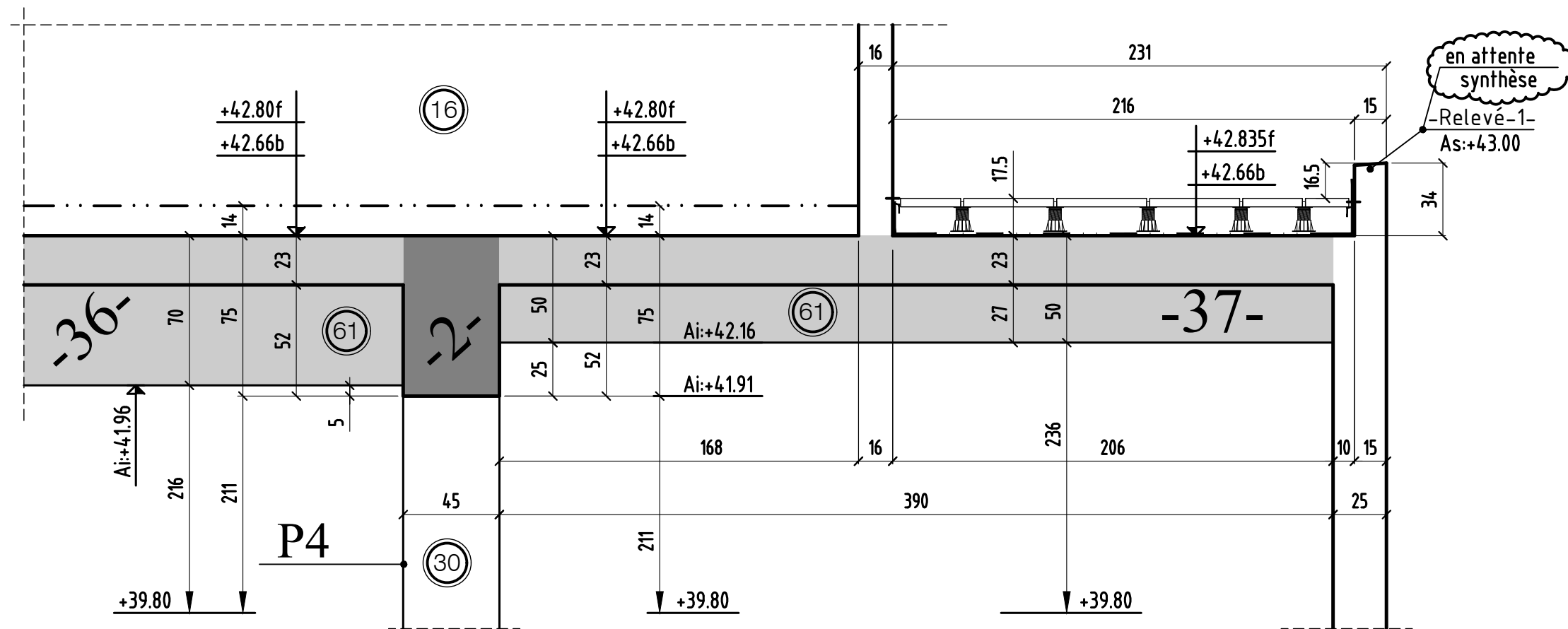

# COUPE 3-3

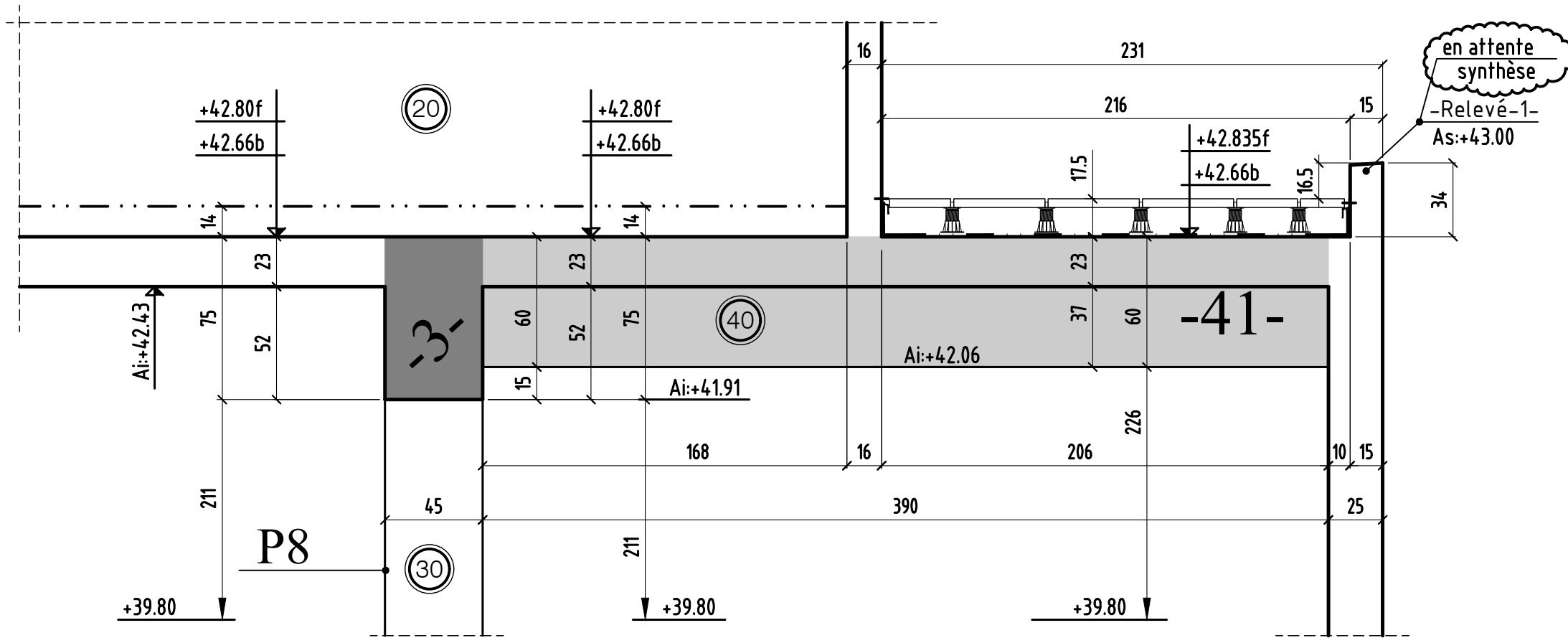

# COUPE 4-4

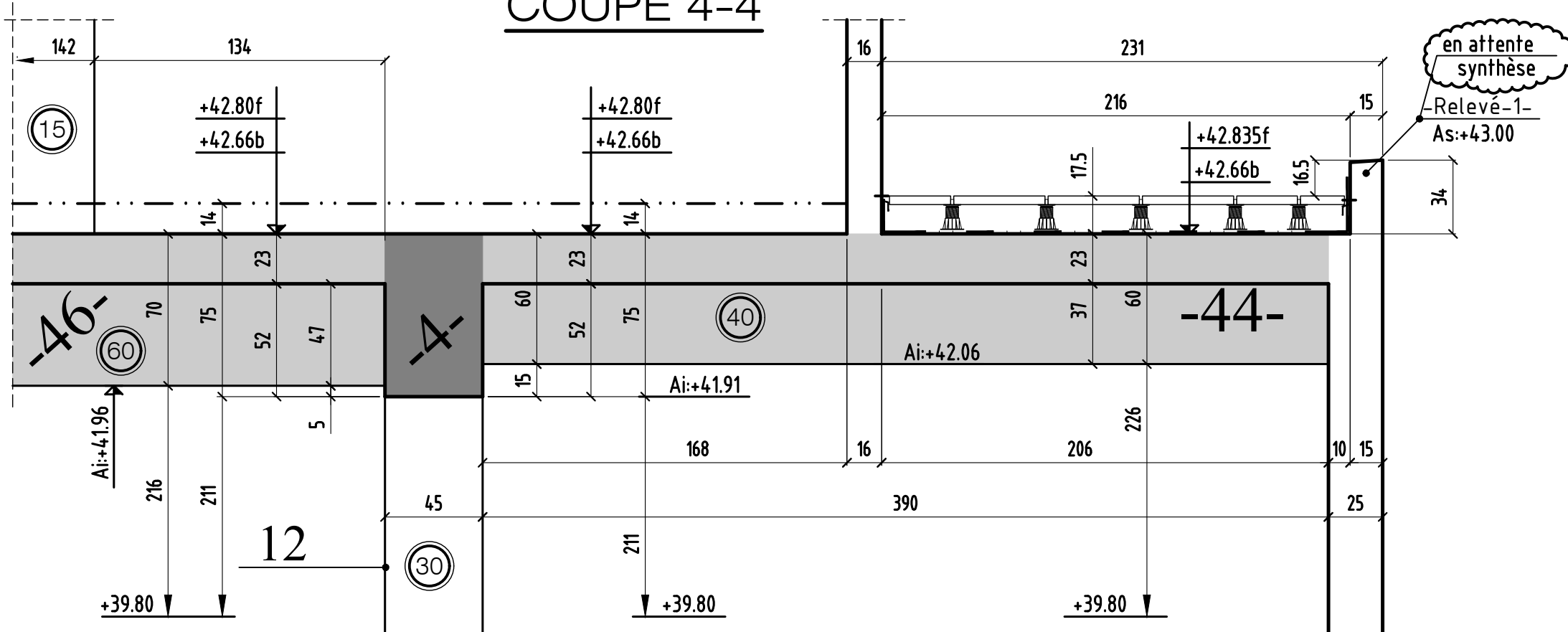

# COUPE 5-5

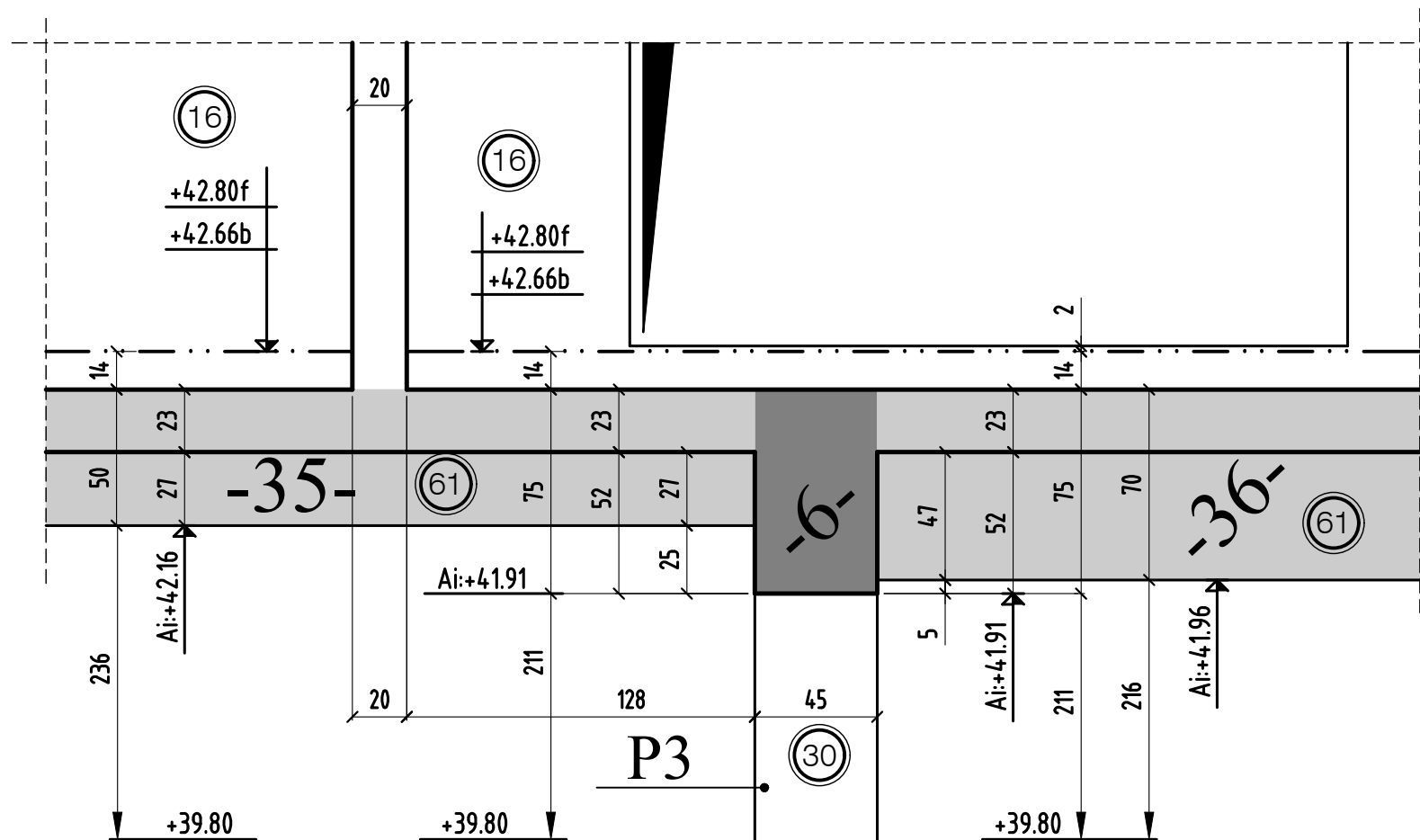

# COUPE 6-6

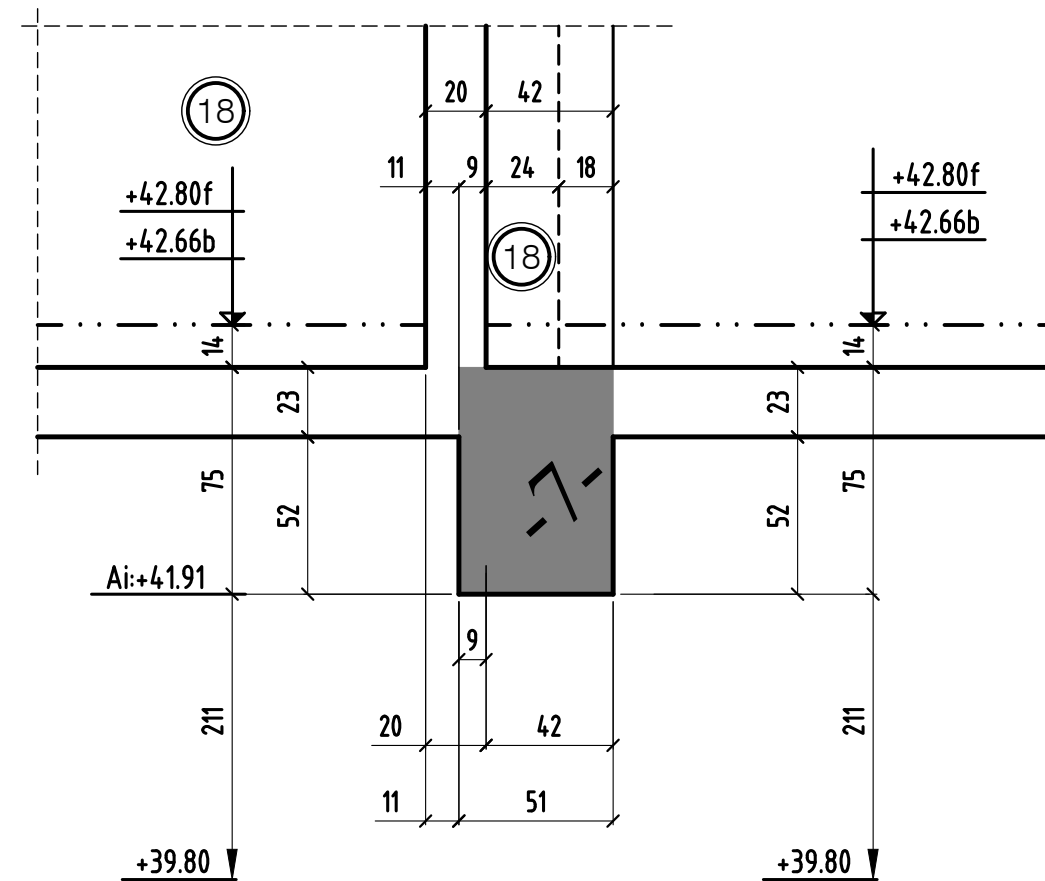

0	MODIFICATIONS	A	AFFAIRE:bâtiment CO	Cahier CO-31
		B		

### COUPE 7-7

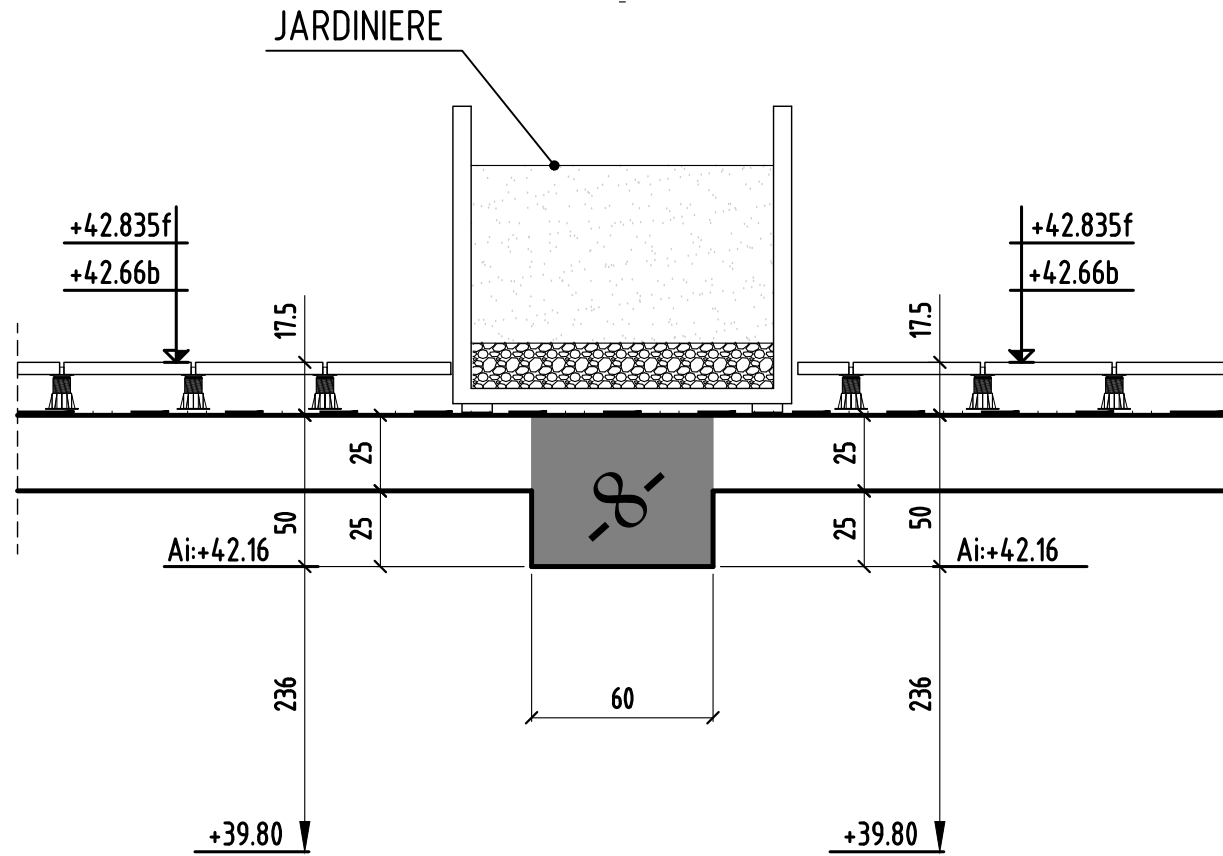

### COUPE 8-8

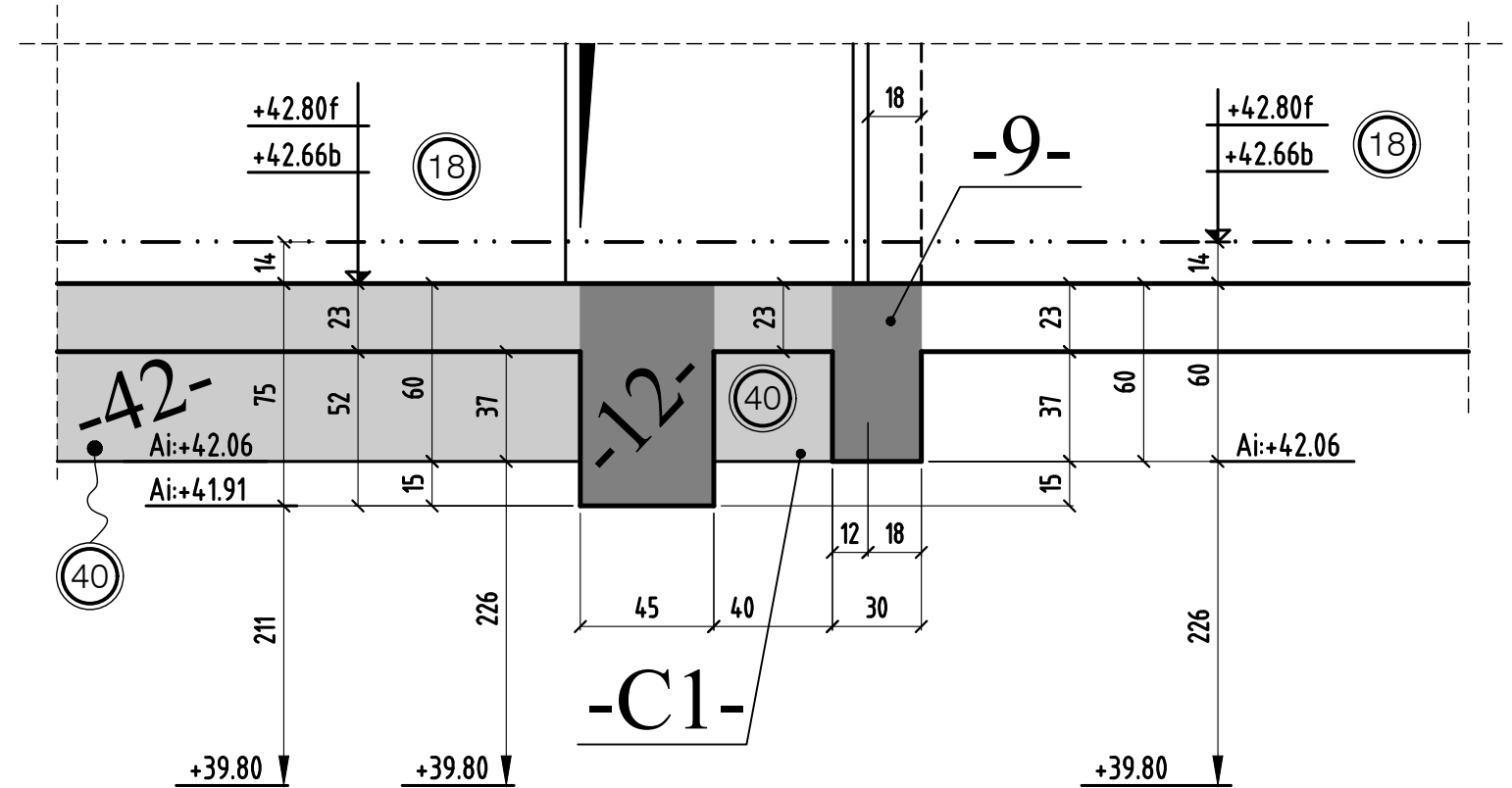

### COUPE 9-9

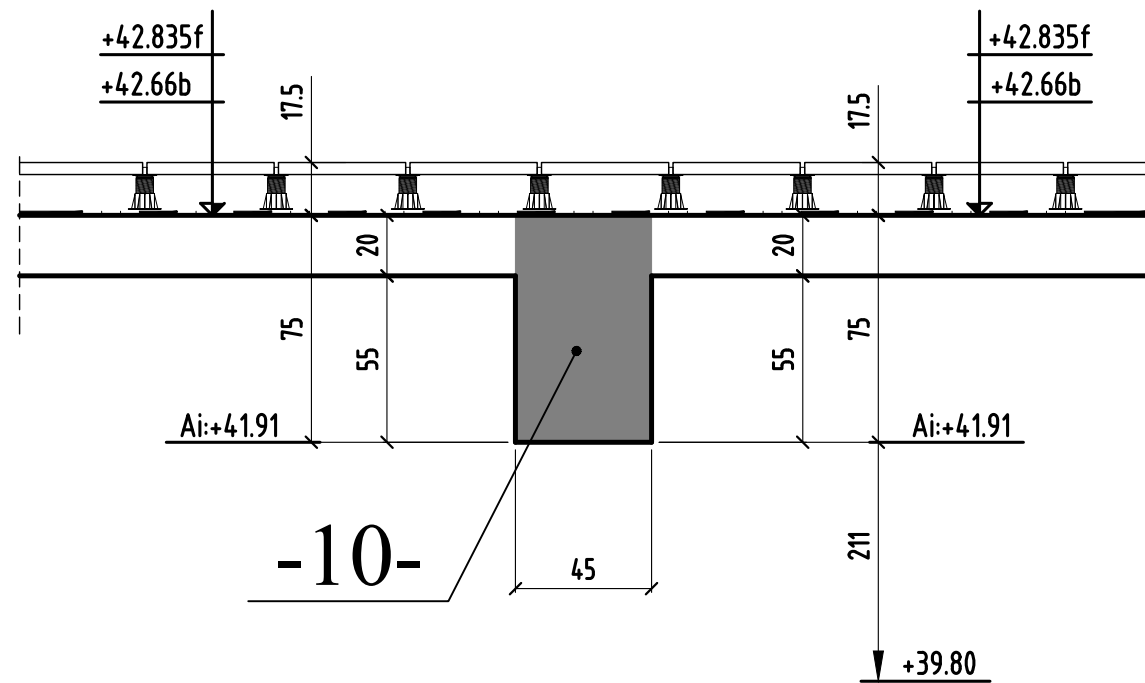

### COUPE 10-10

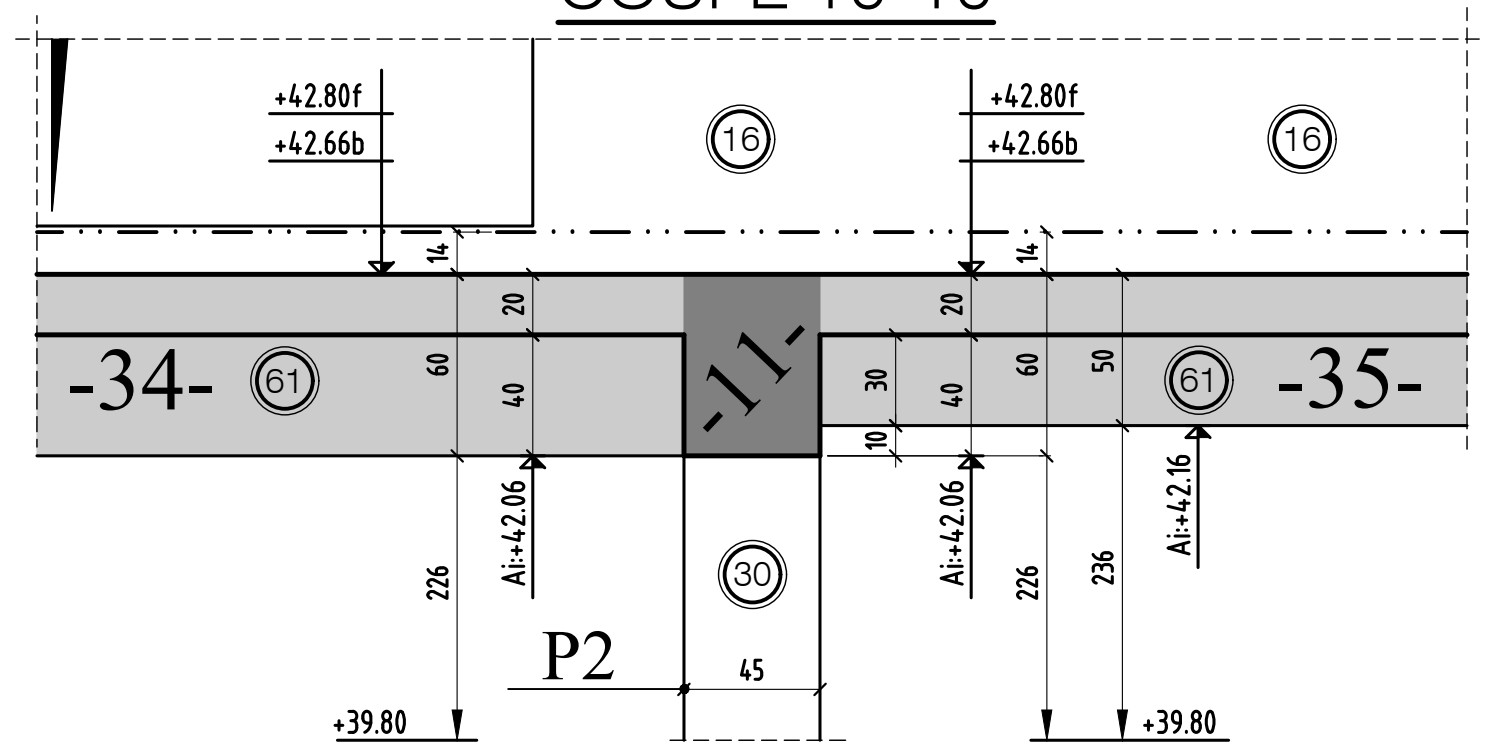

### COUPE 11-11

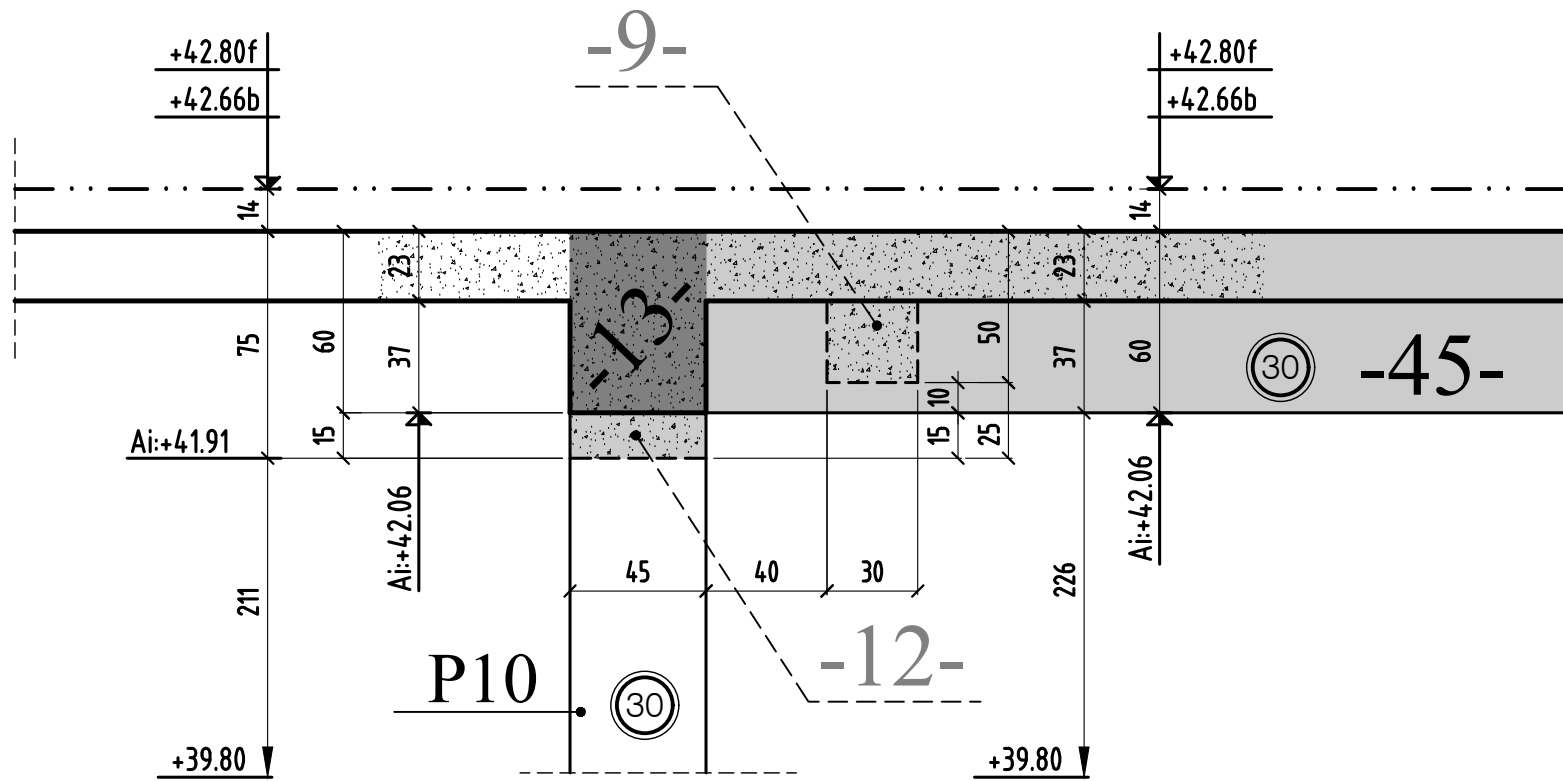

### COUPE 12-12

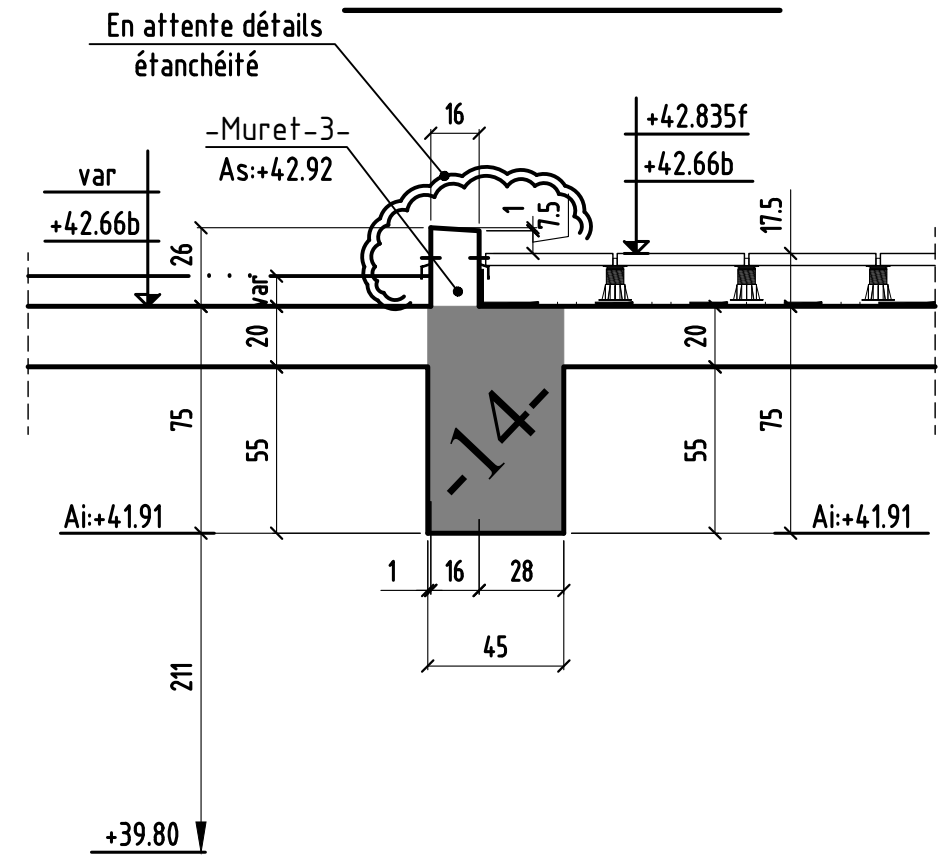

### COUPE 13-13

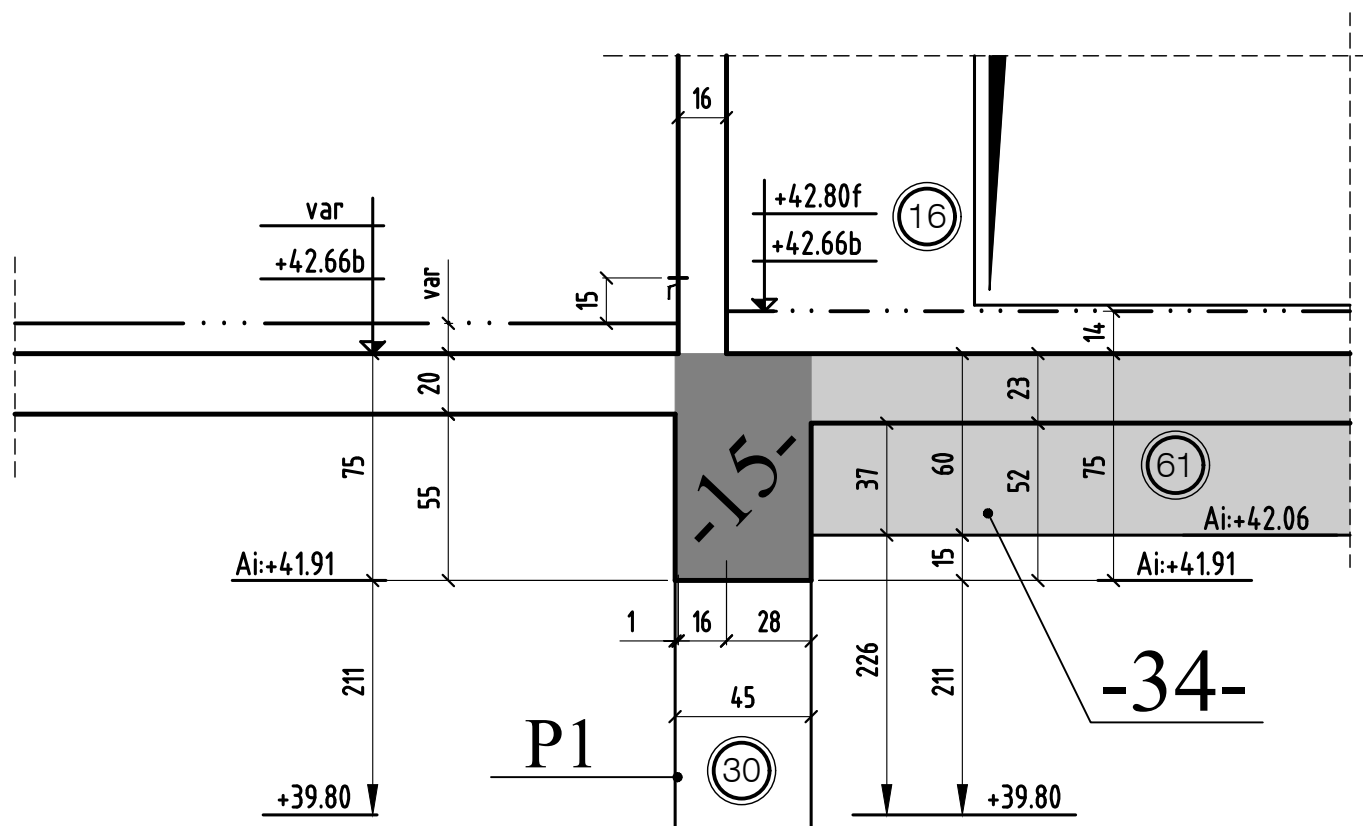

### COUPE 14-14

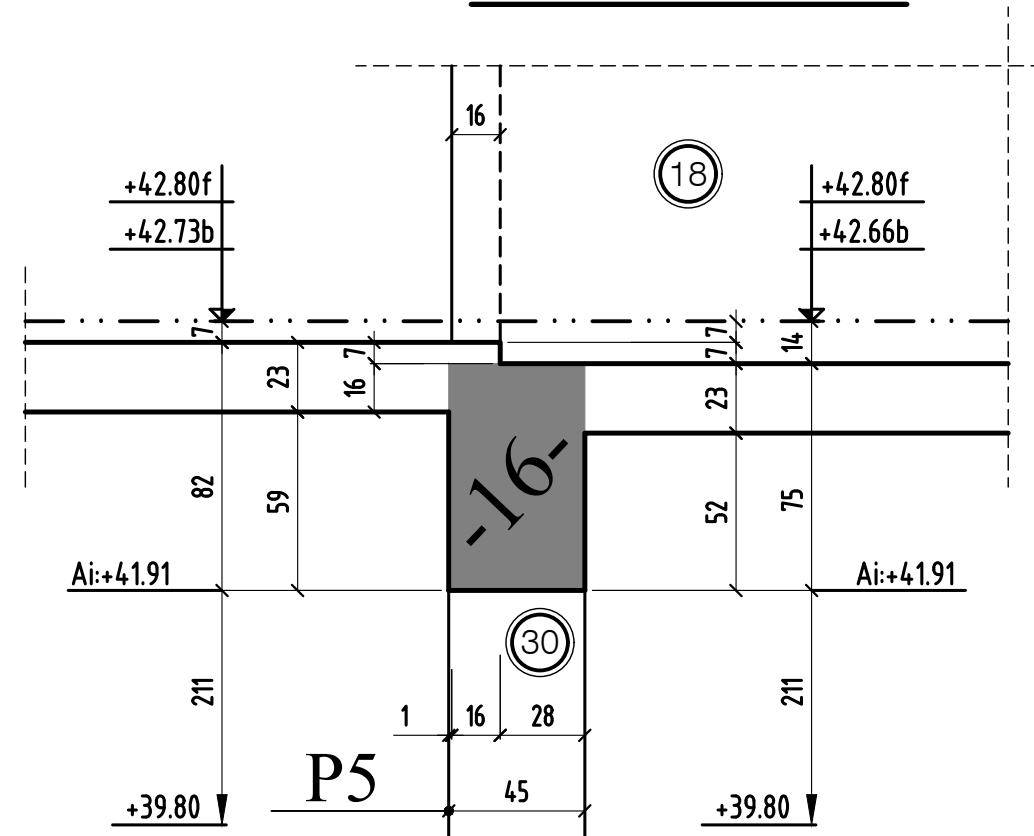

### COUPE 15-15

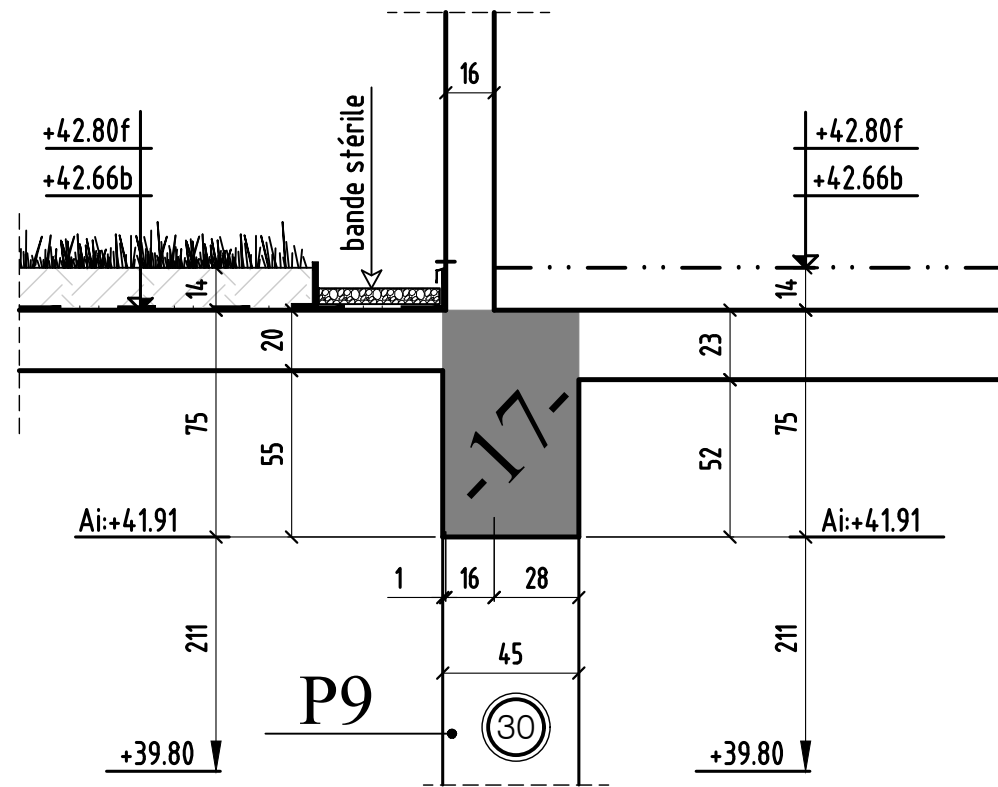

### COUPE 16-16

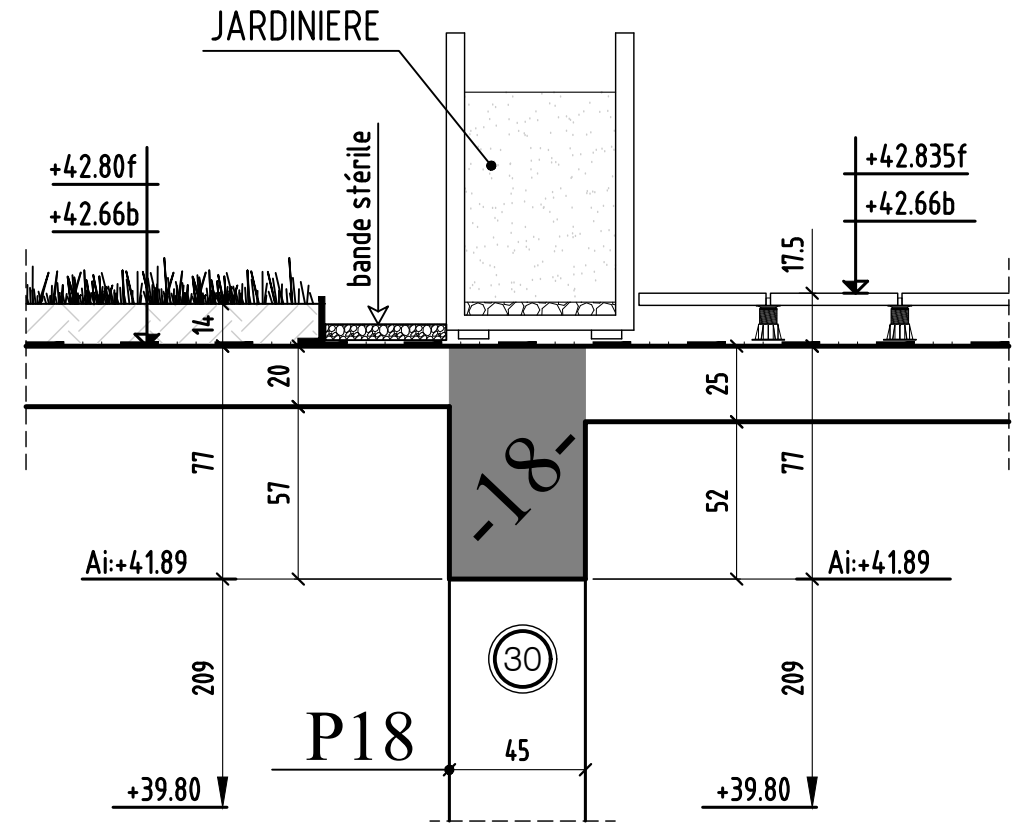

### COUPE 17-17

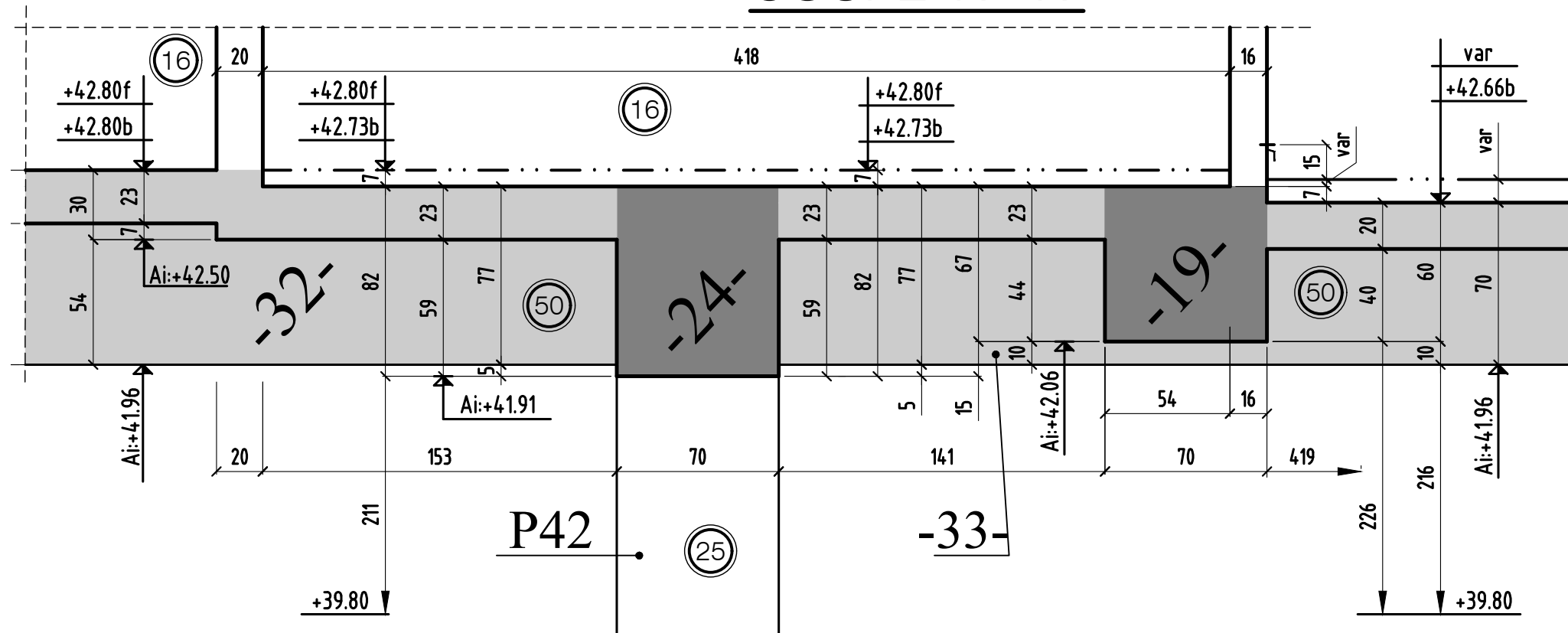



### COUPE 18-18

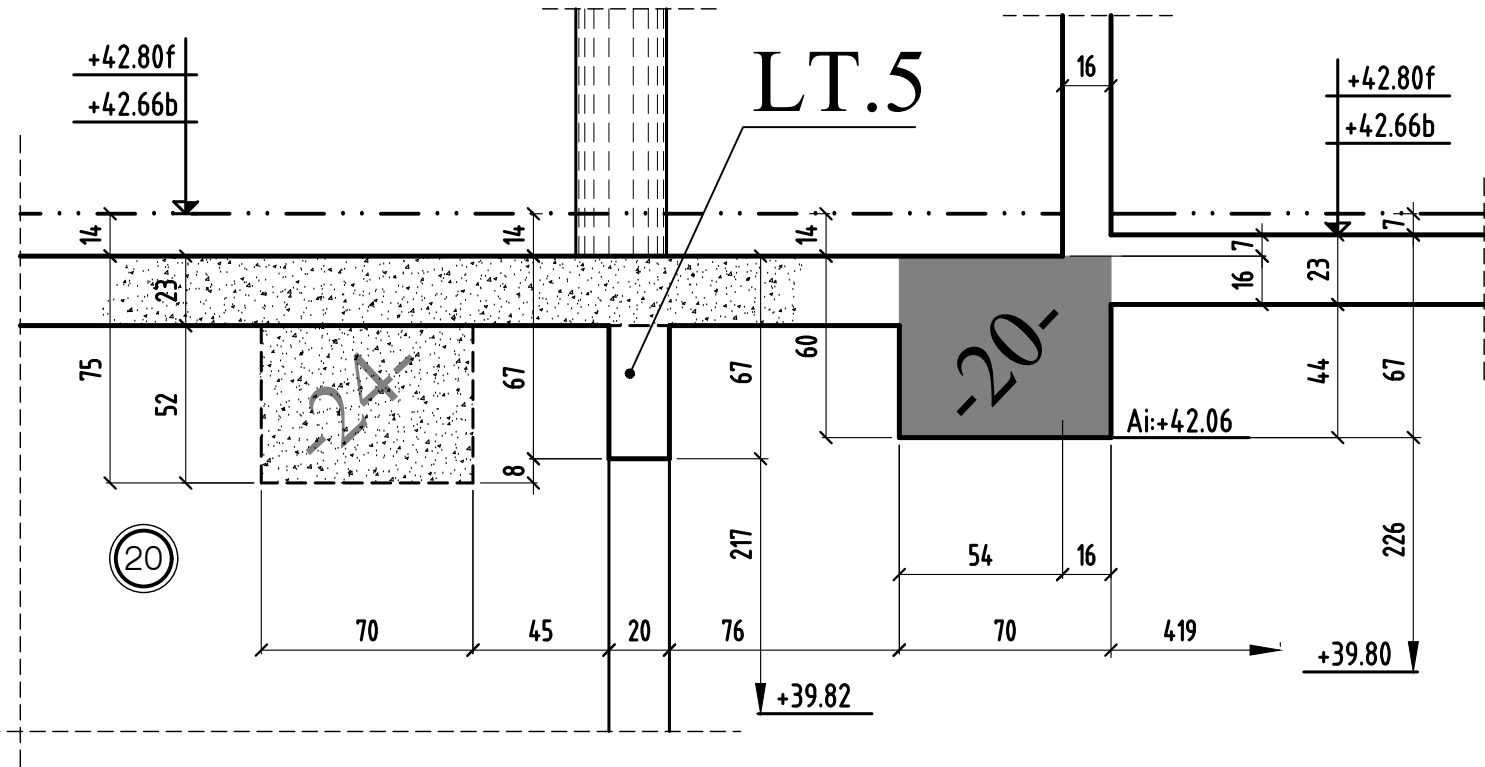

### COUPE 19-19

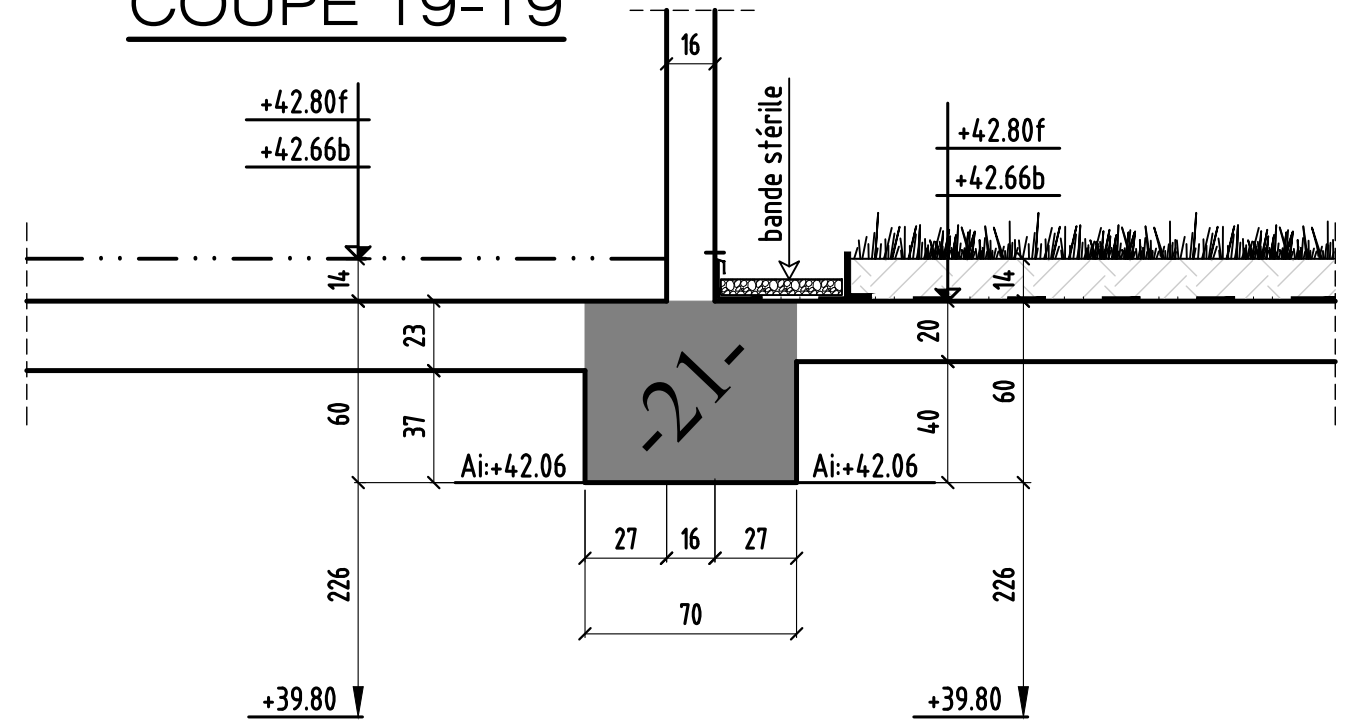

### COUPE 20-20

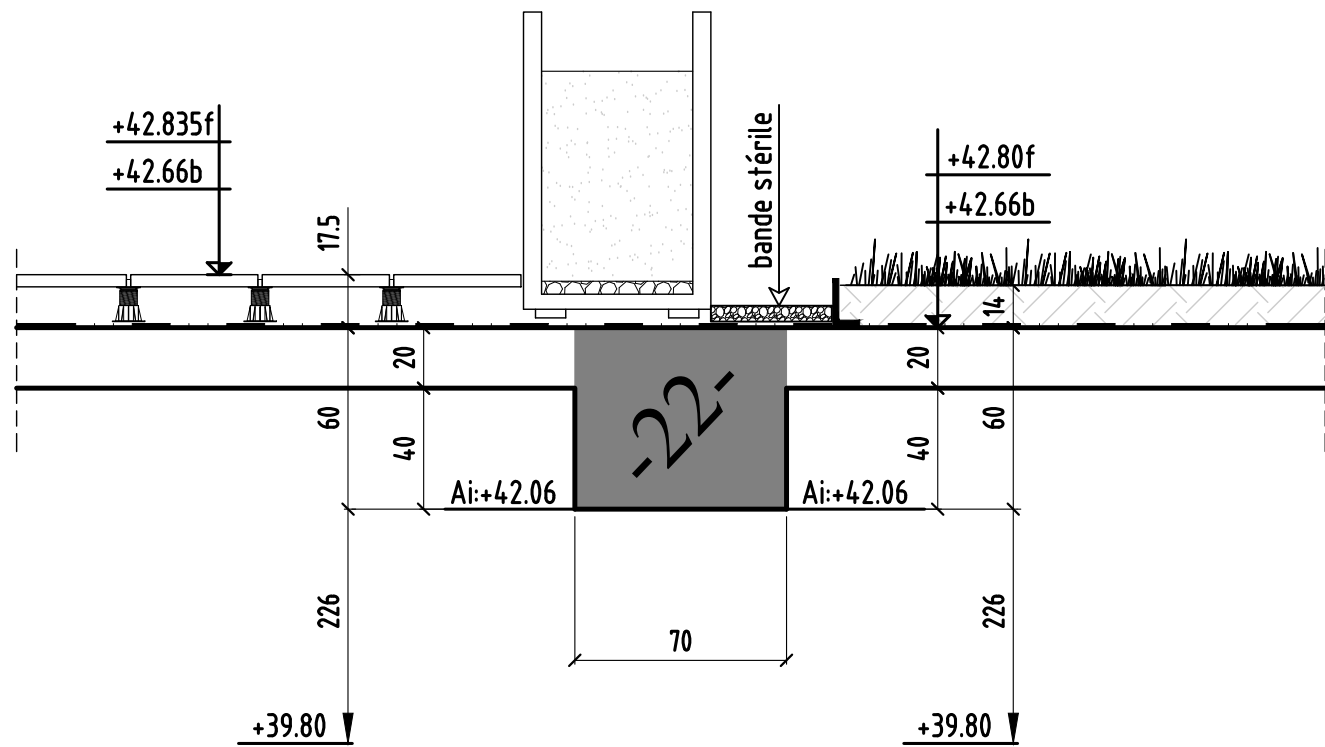

### COUPE 21-21

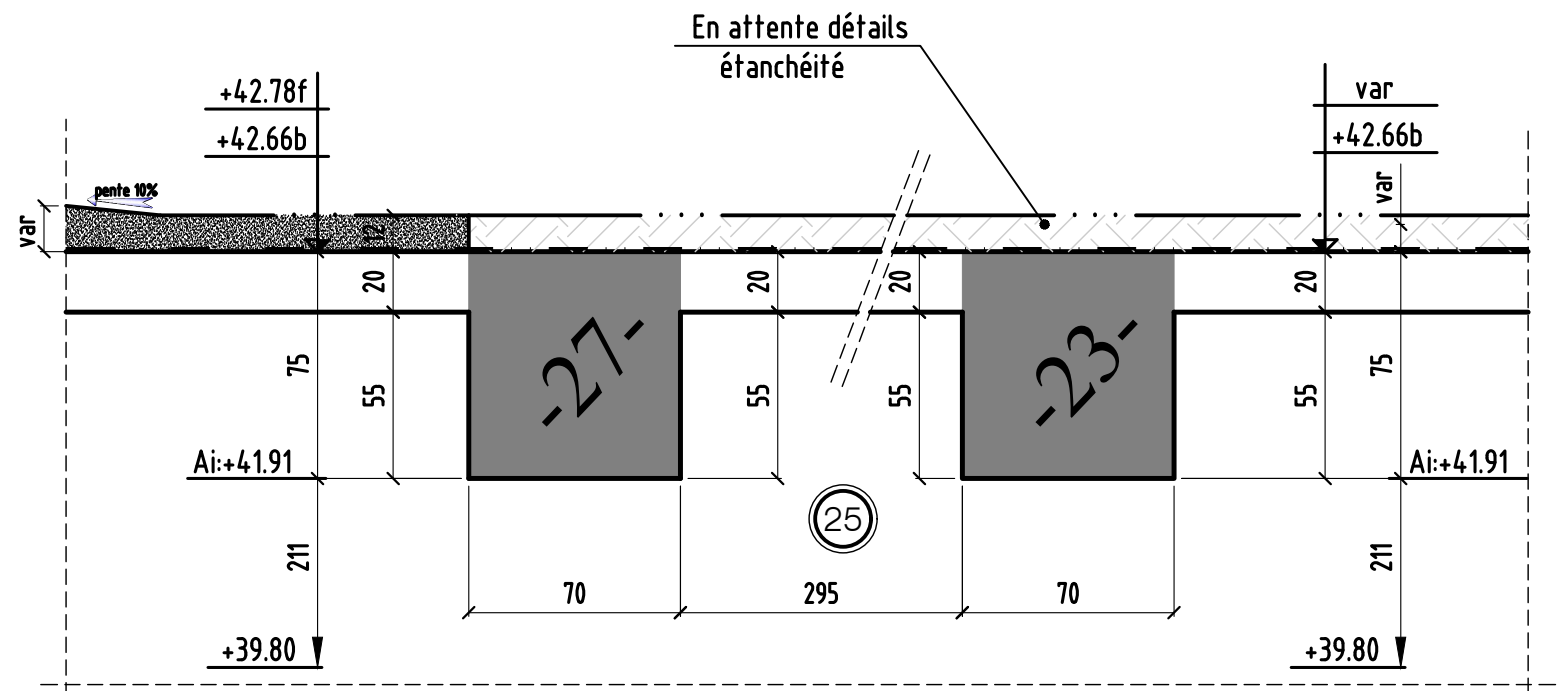

# COUPE 22-22

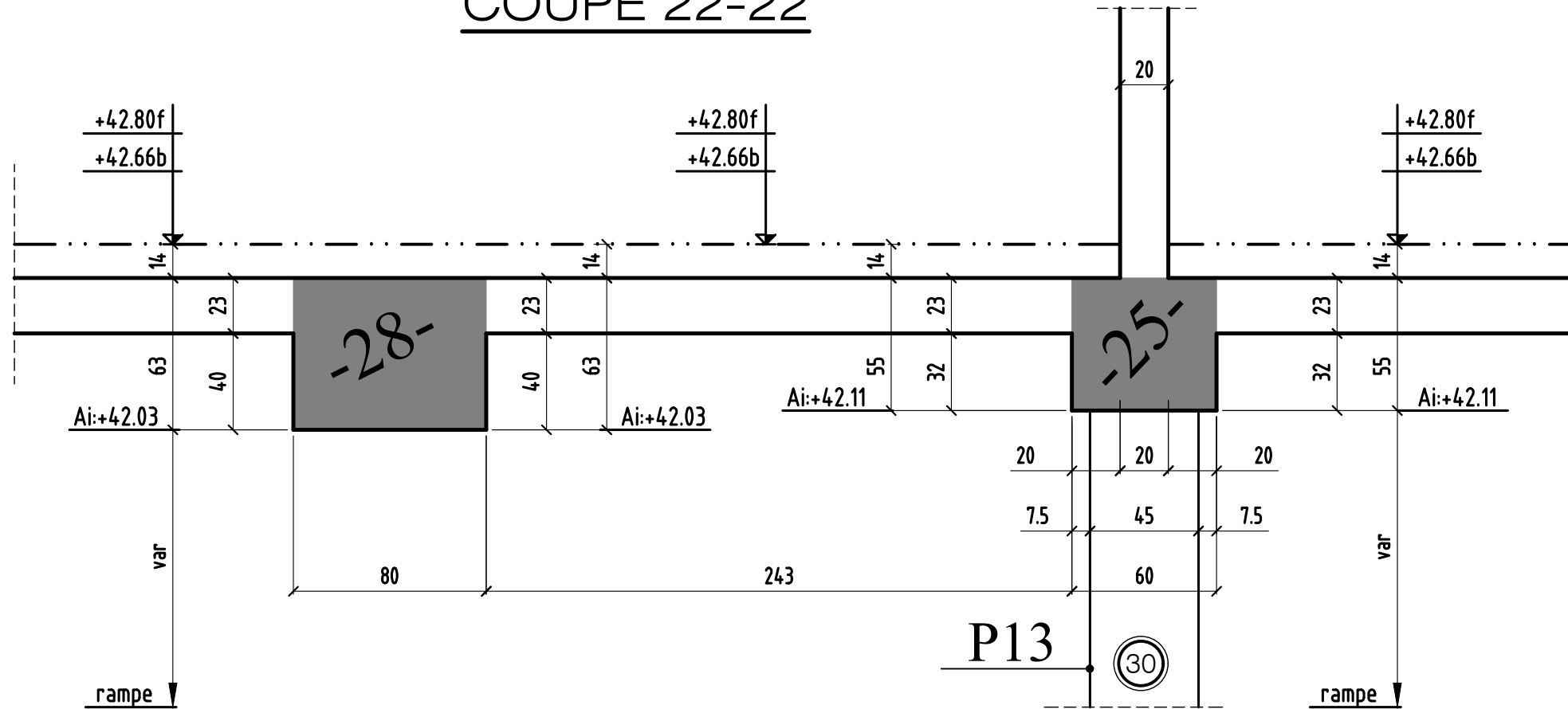

# COUPE 23-23

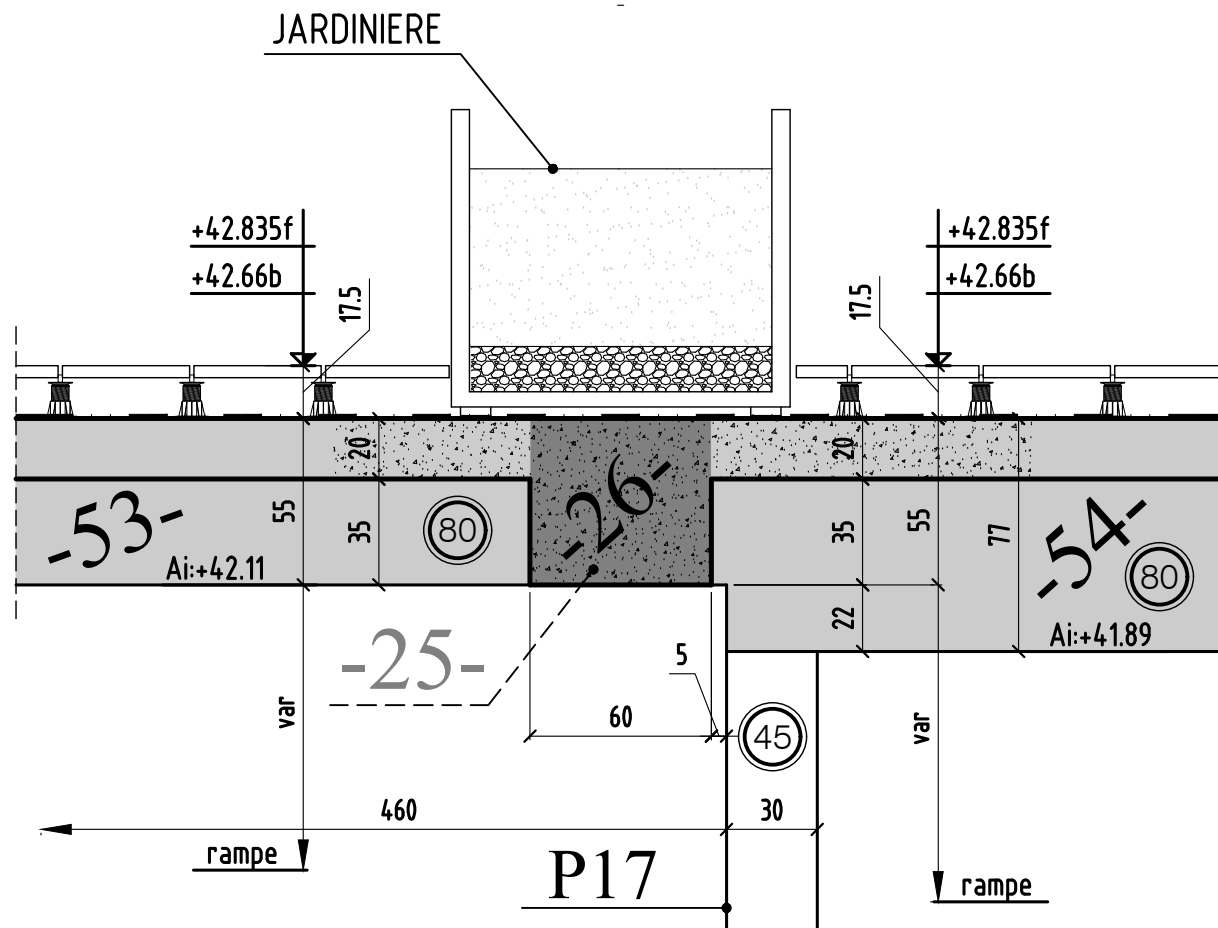

# COUPE 24-24

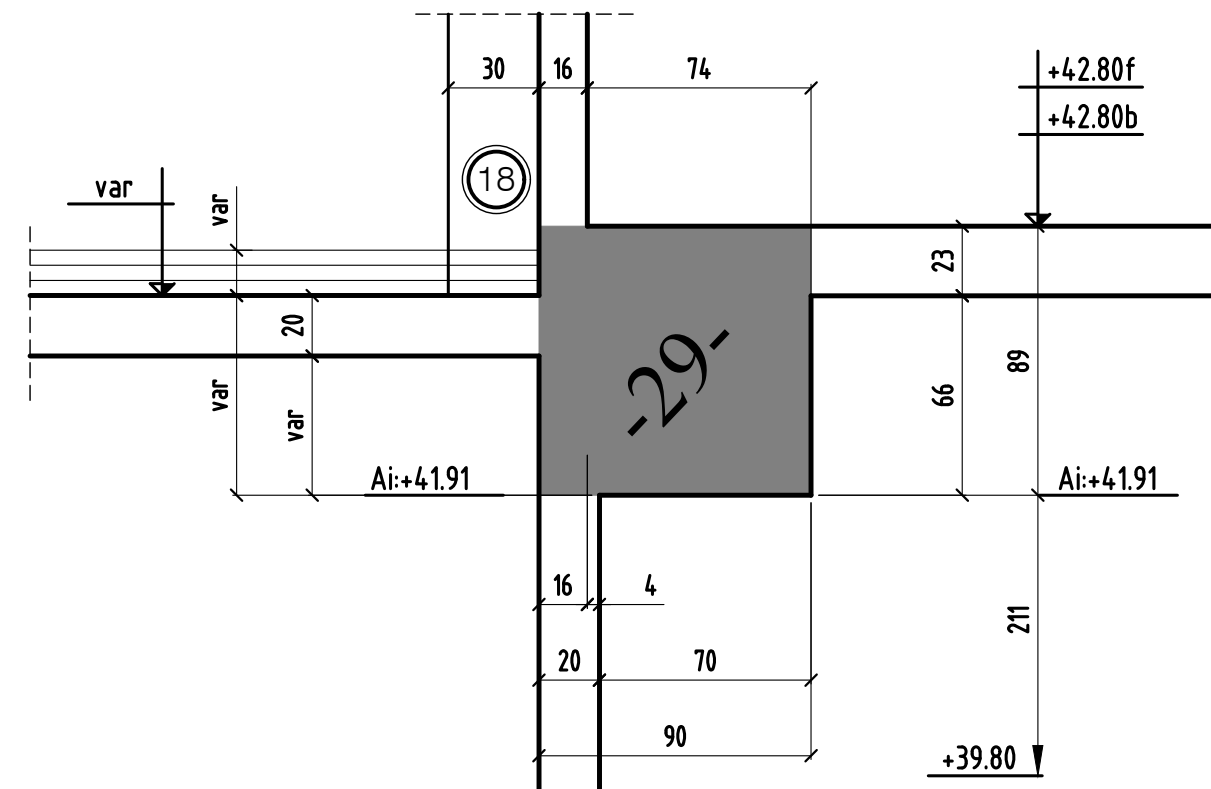



### COUPE 29-29

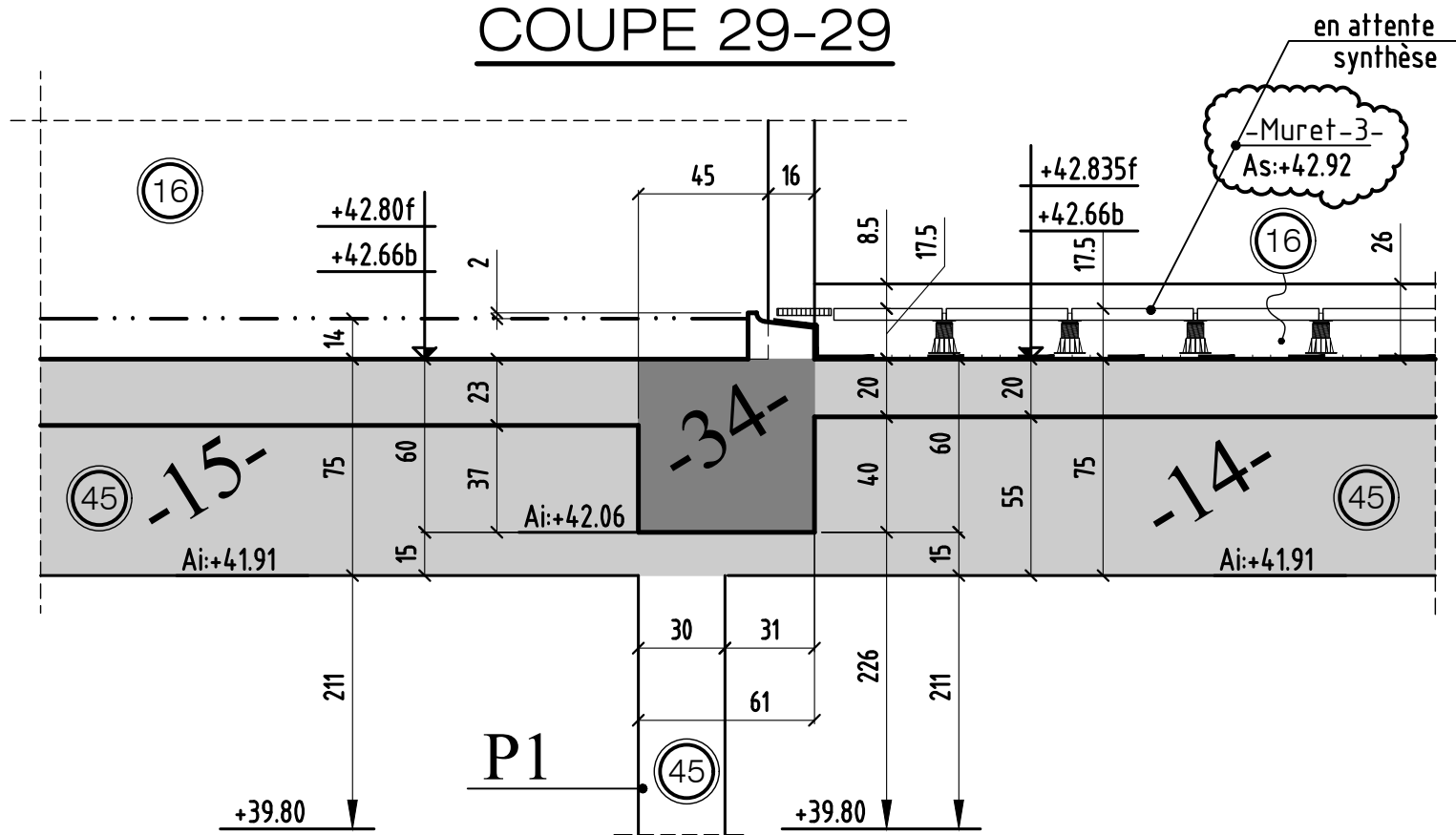

### COUPE 30-30

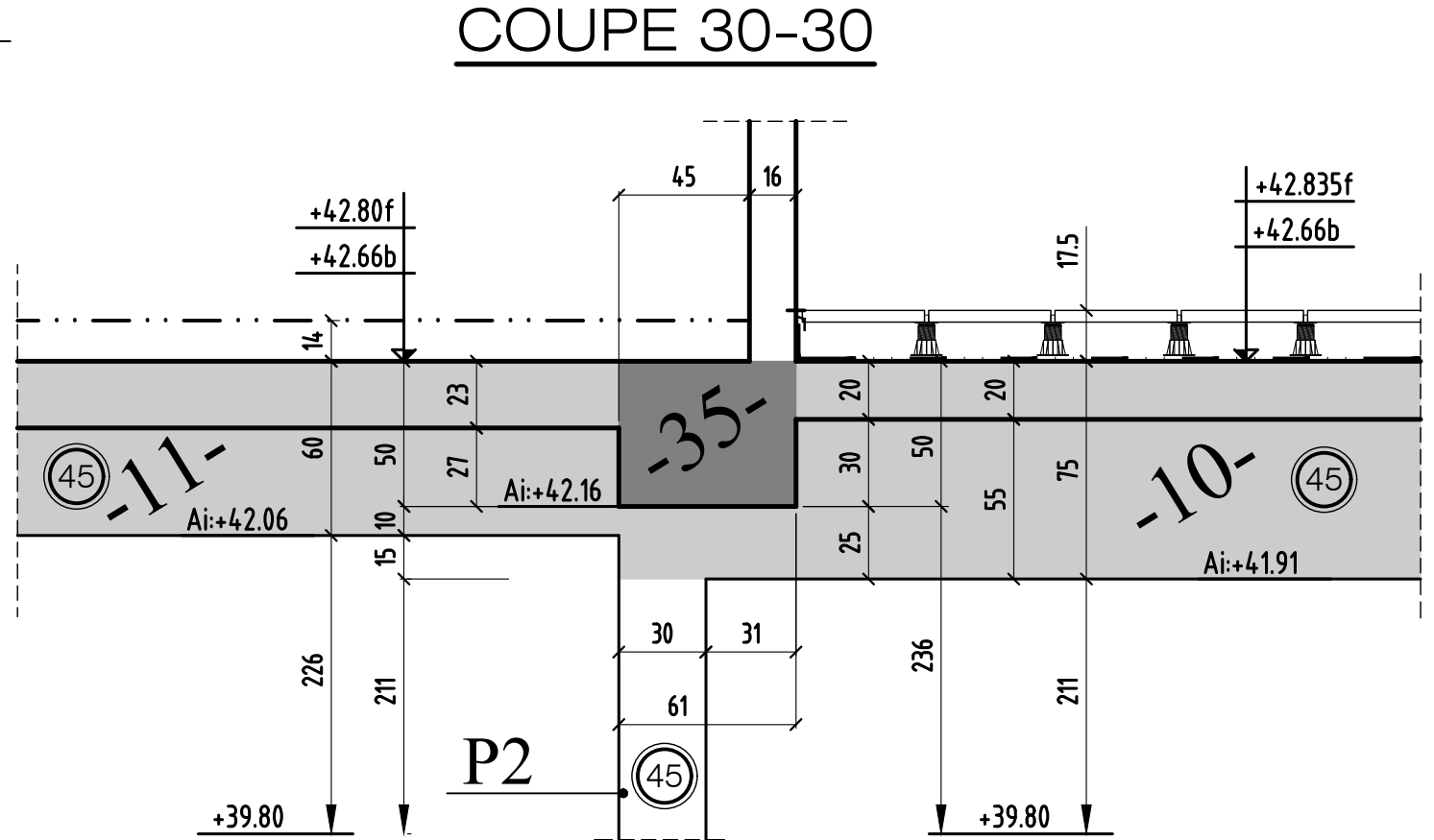

### COUPE 31-31

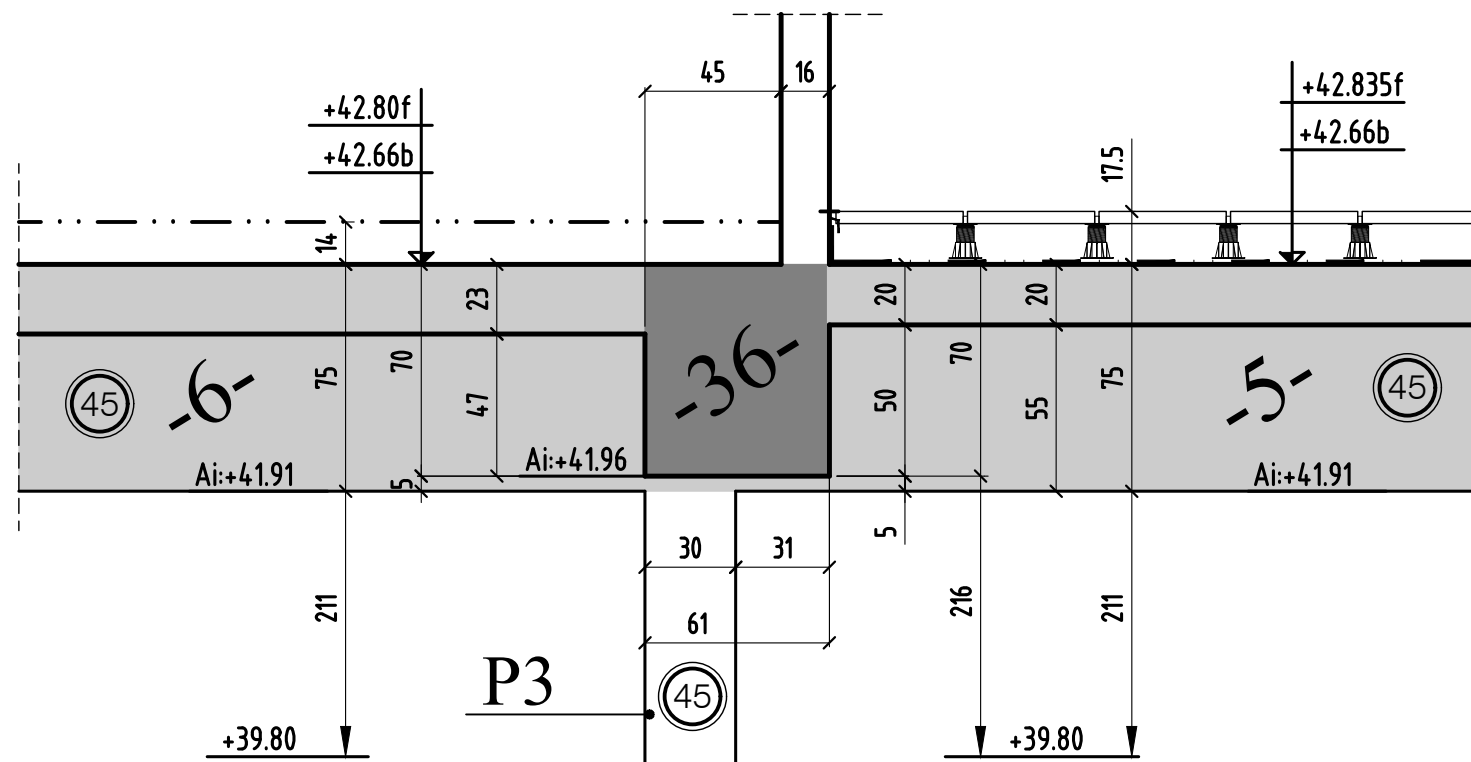

### COUPE 32-32

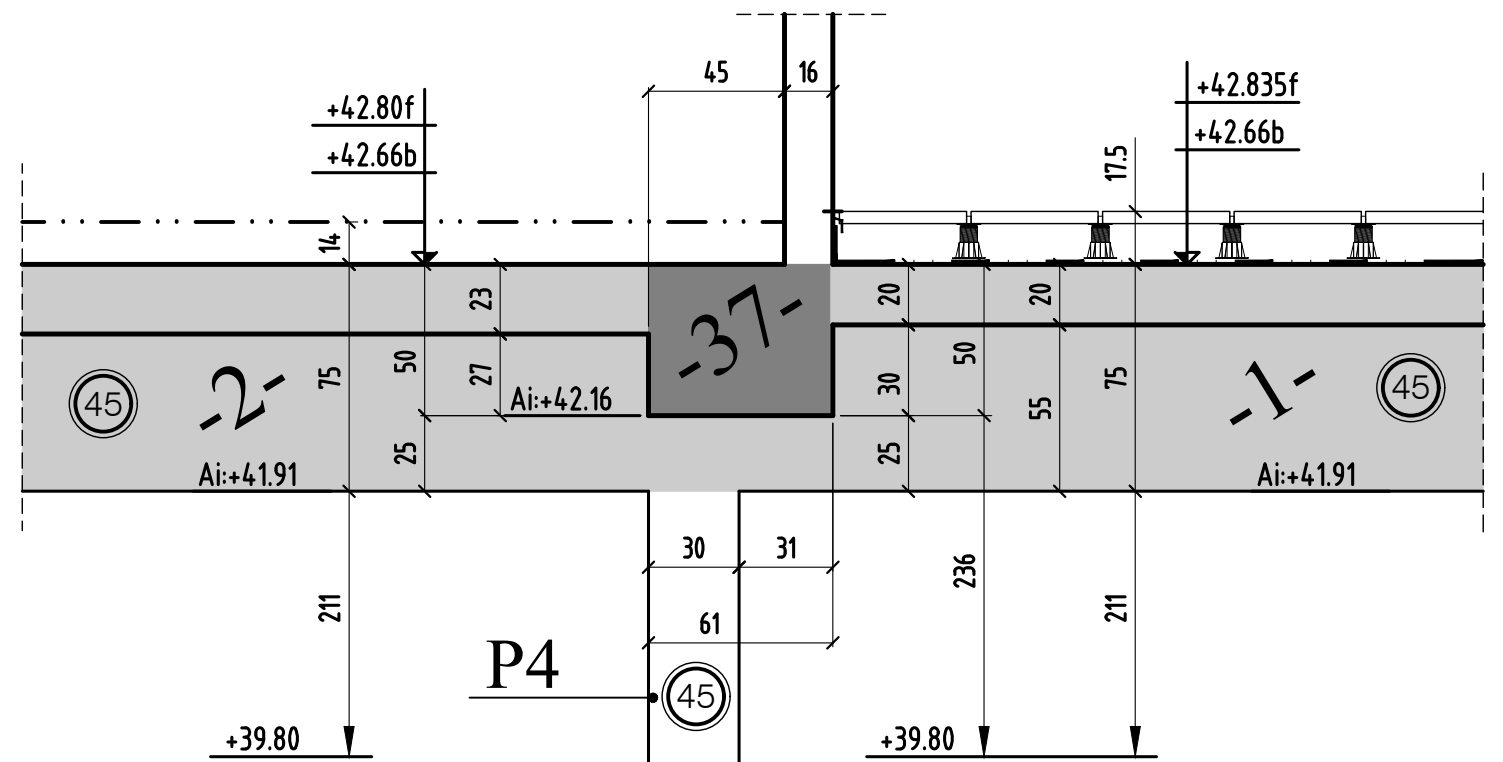

# COUPE 33-33

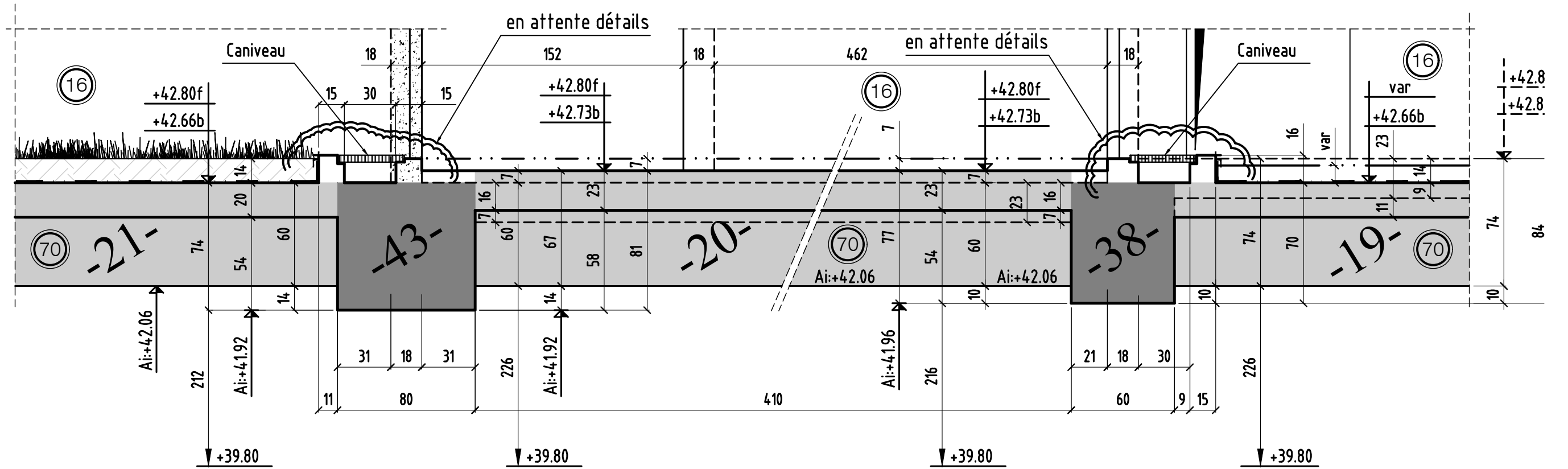

# COUPE 34-34

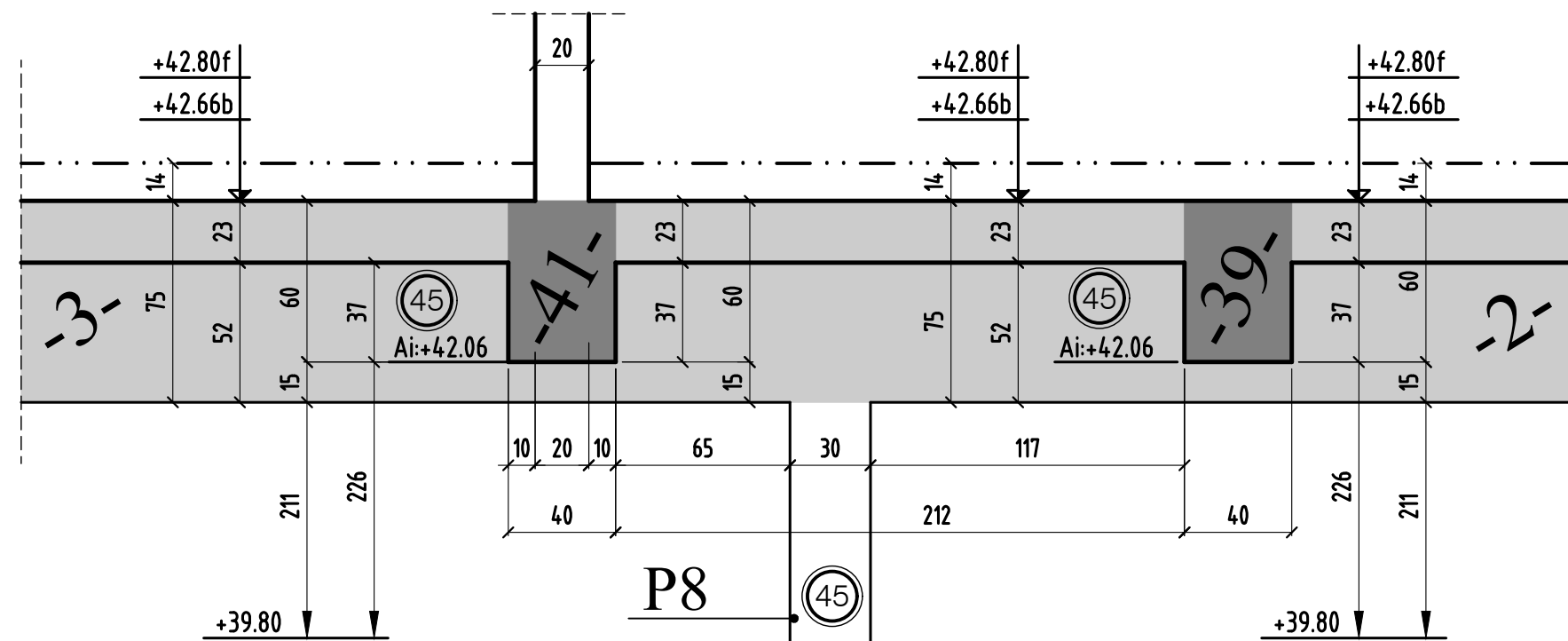

## COUPE 35-35

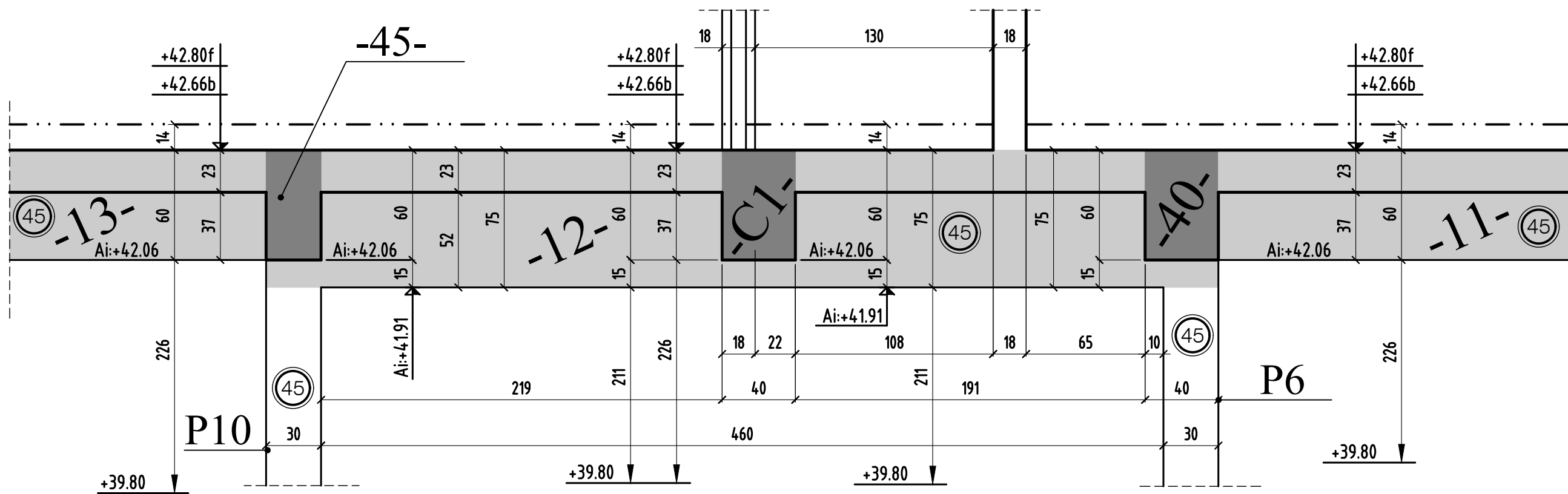

## COUPE 36-36

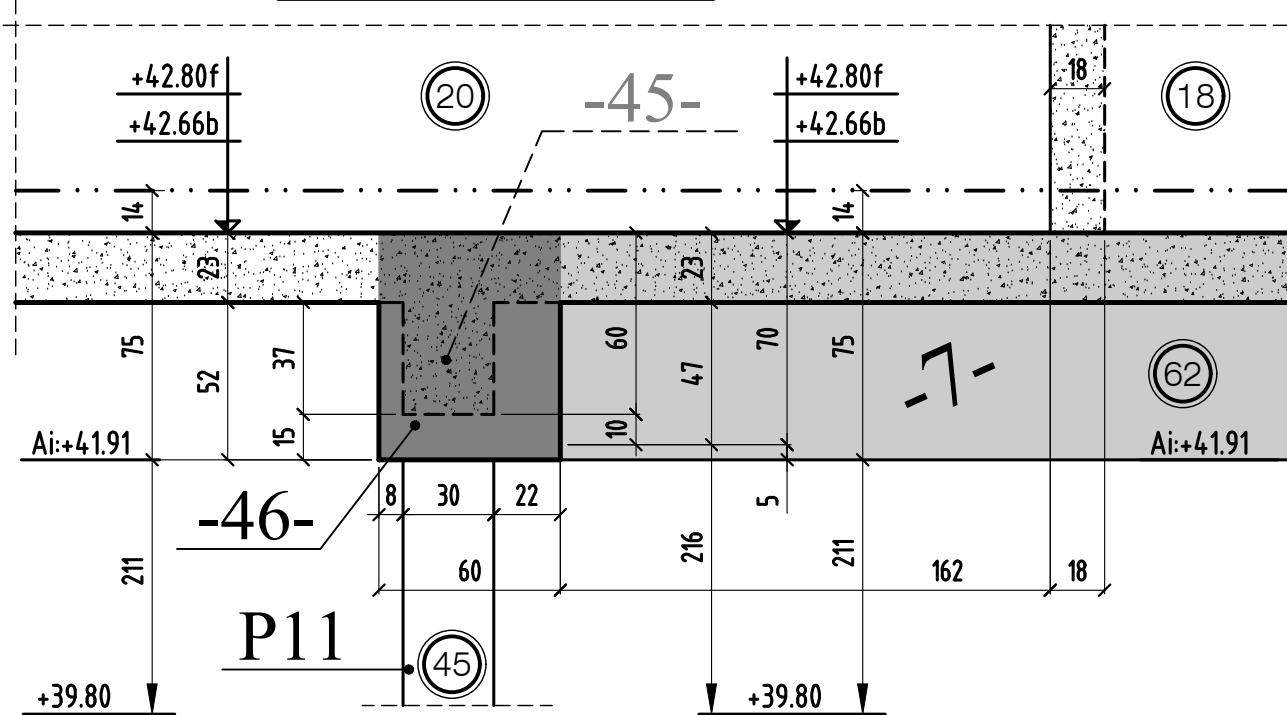

## COUPE 37-37

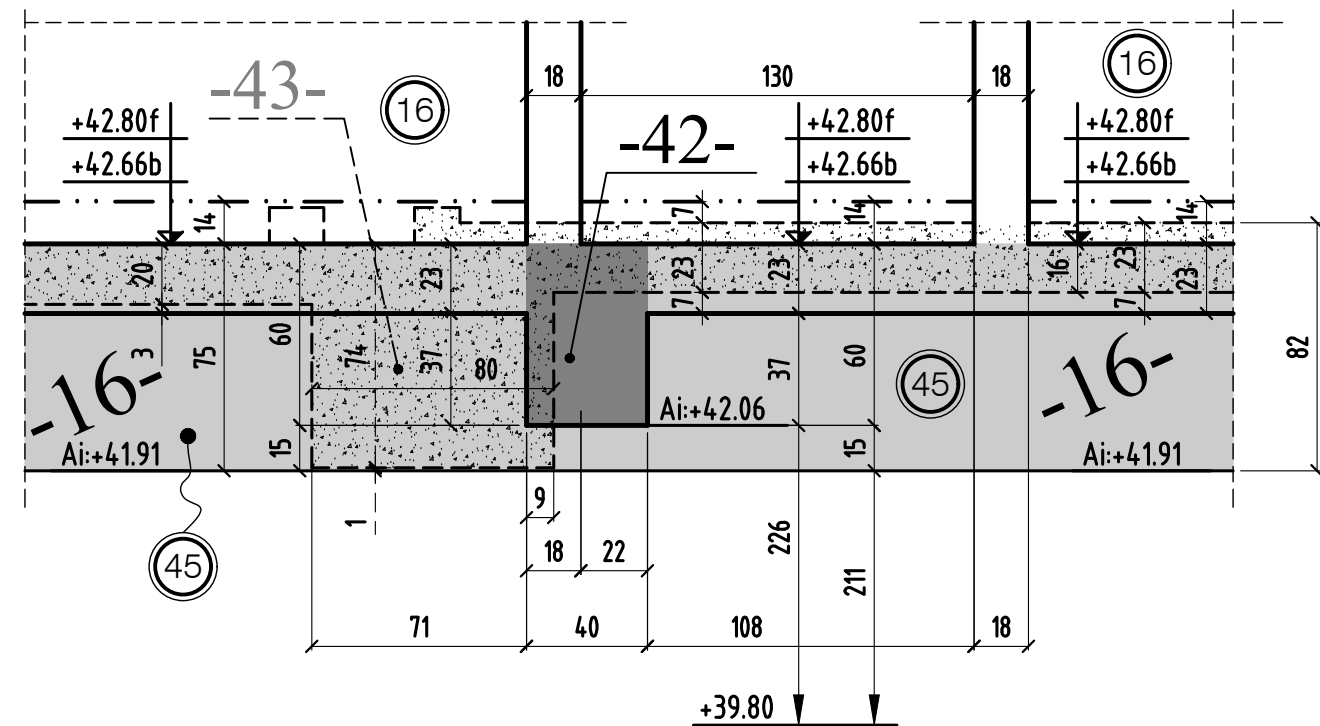

# COUPE 38-38

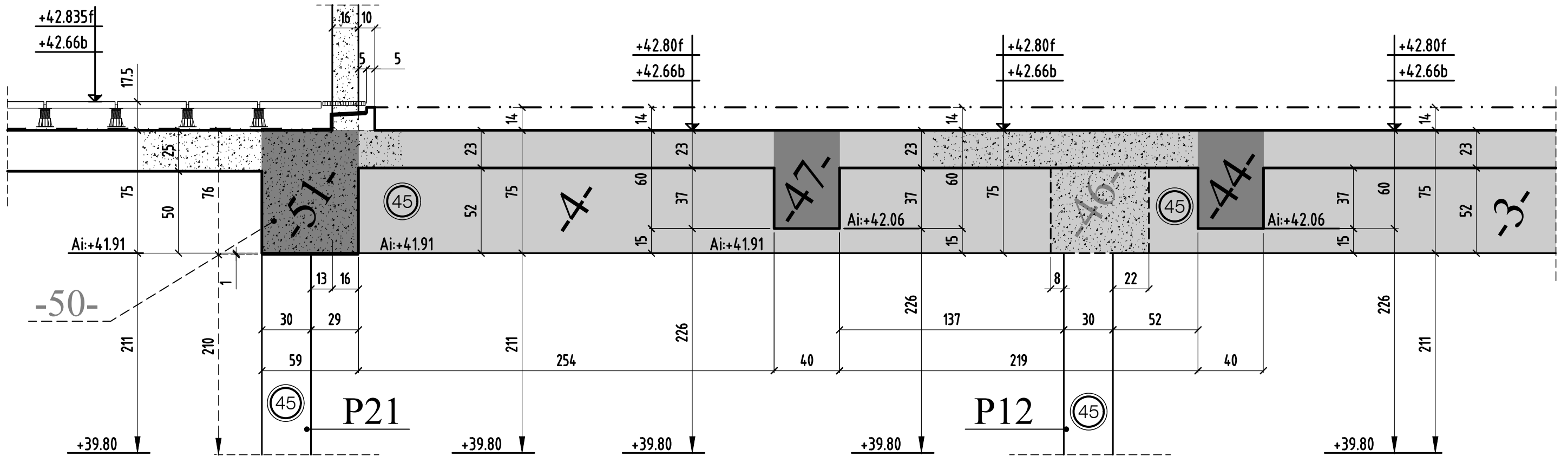

# COUPE 39-39

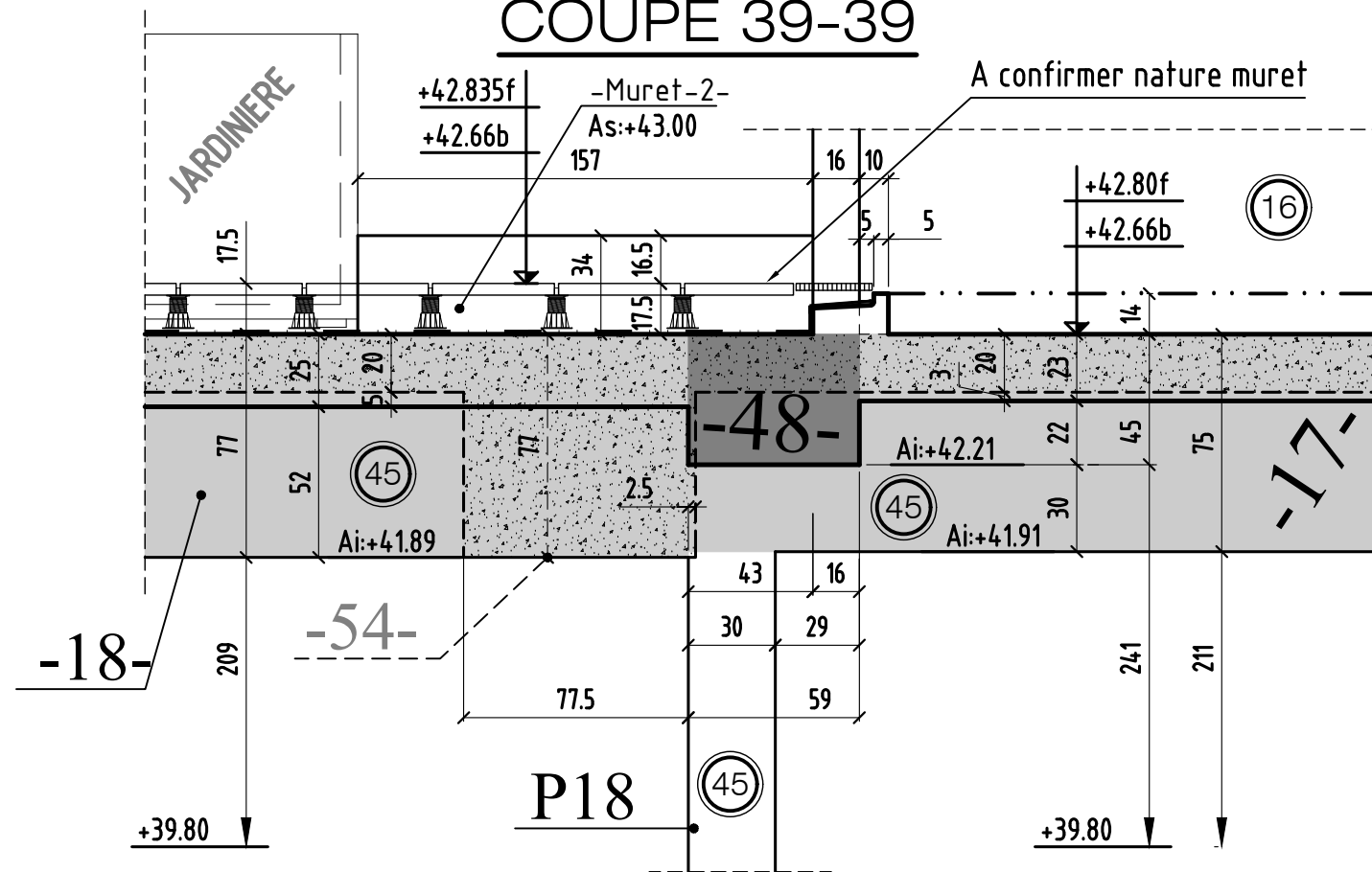

### COUPE 40-40

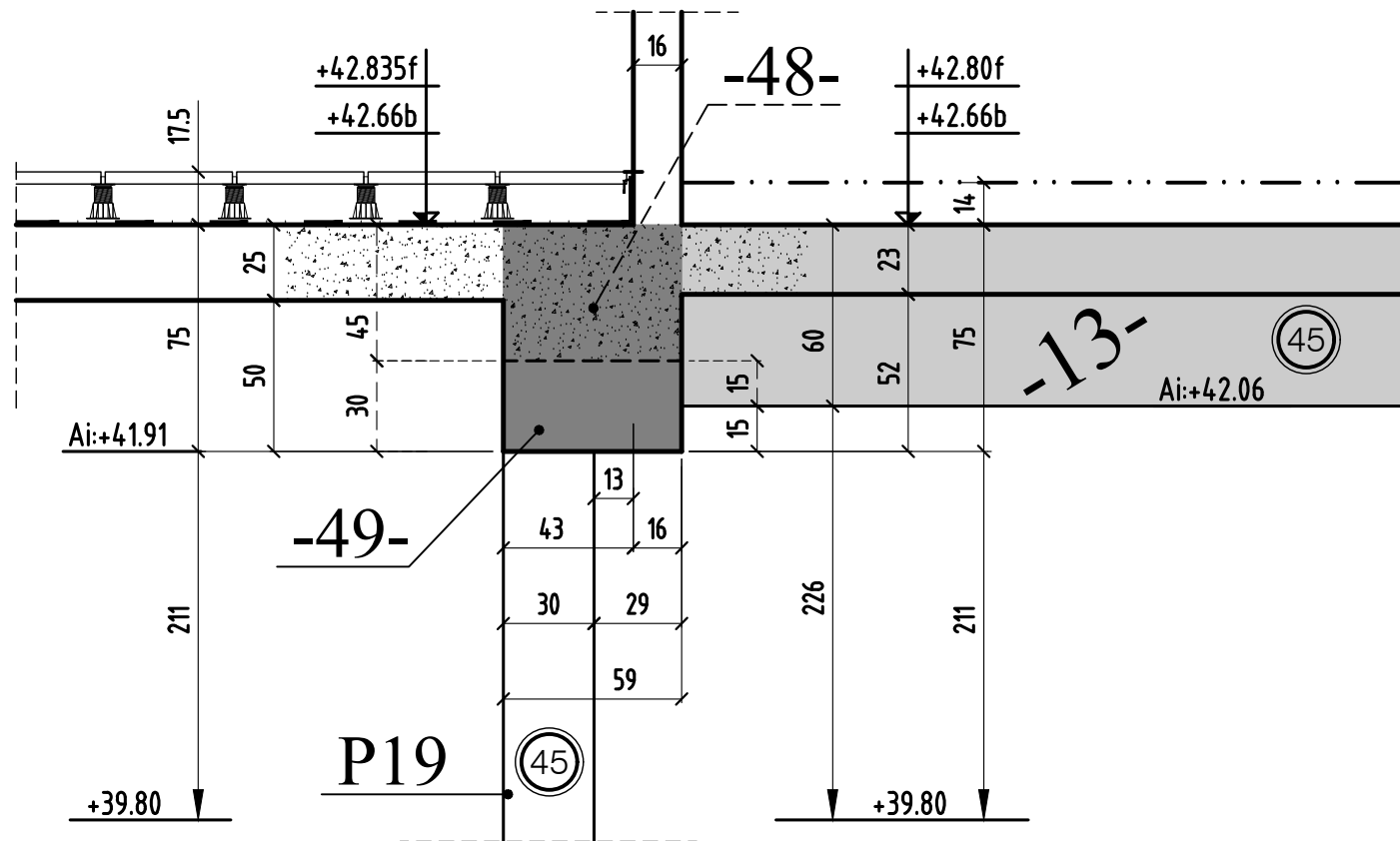

### COUPE 41-41

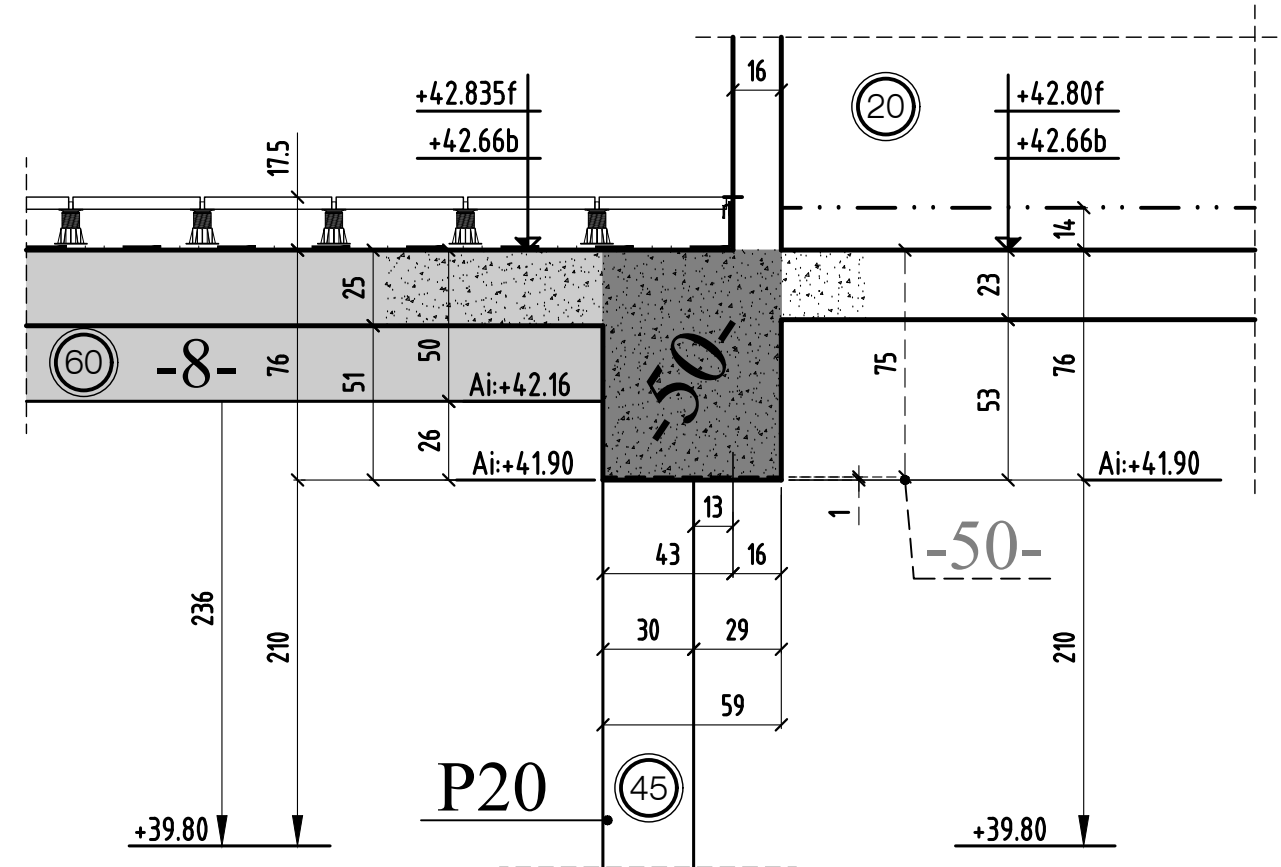

### COUPE 42-42

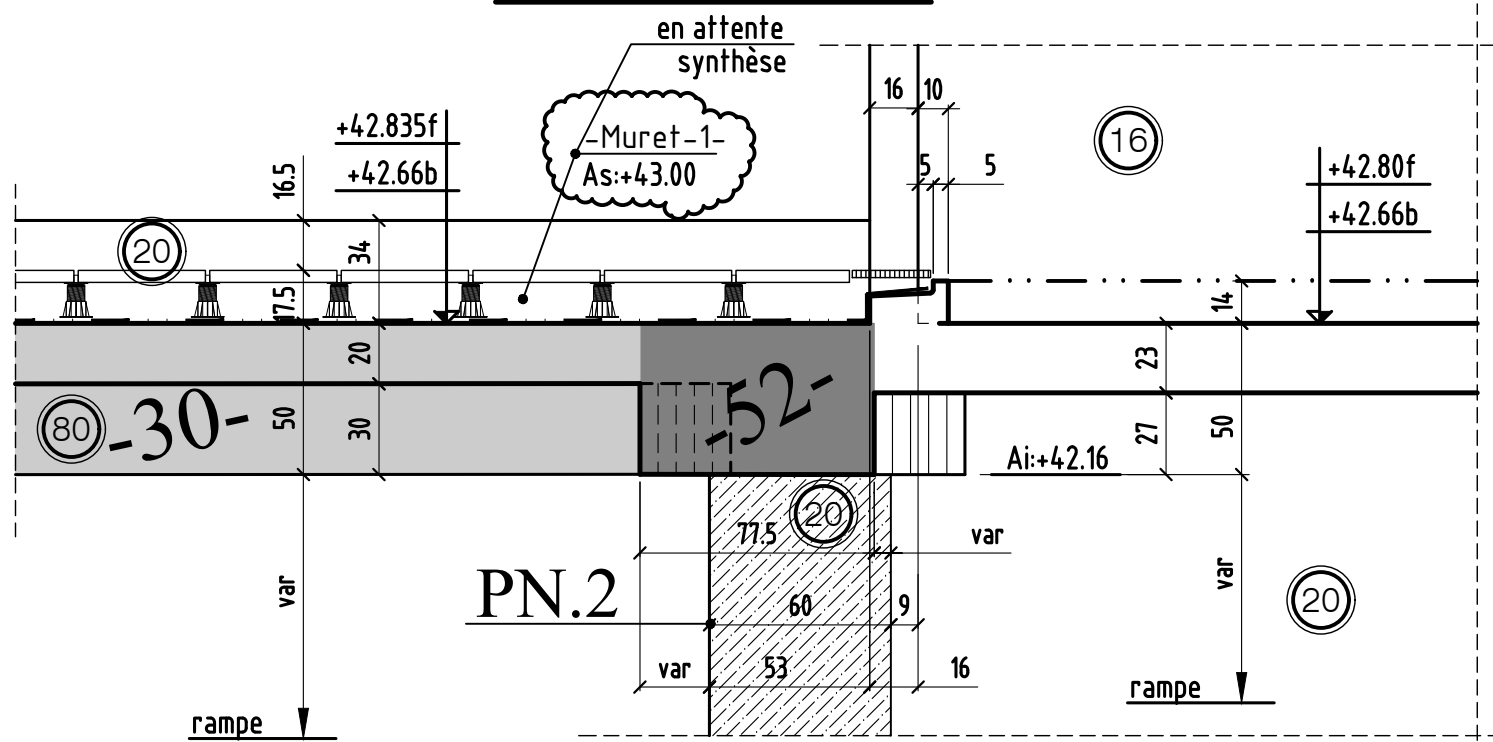

### COUPE 43-43

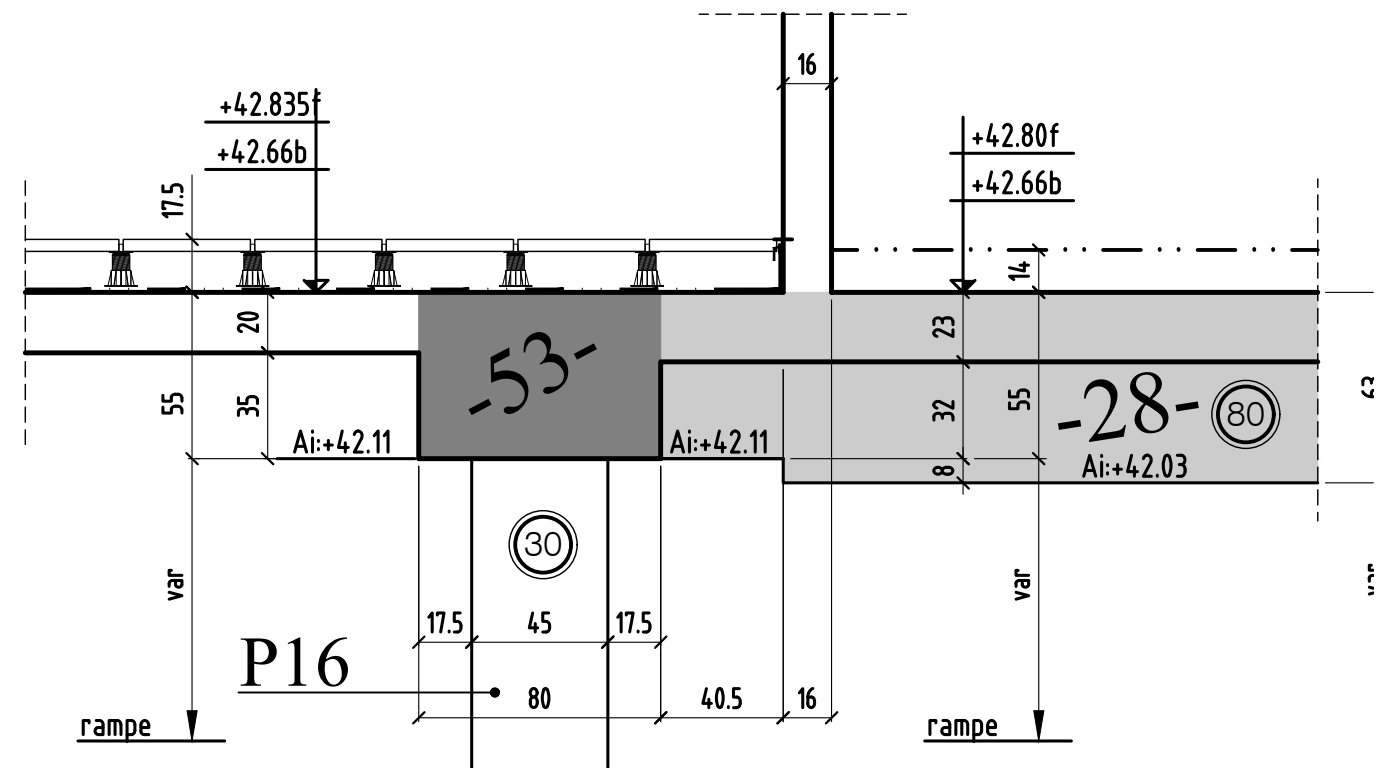

0	MODIFICATIONS	A	AFFAIRE:bâtiment CO	Cahier CO-31
		B	Ech:1/25	14



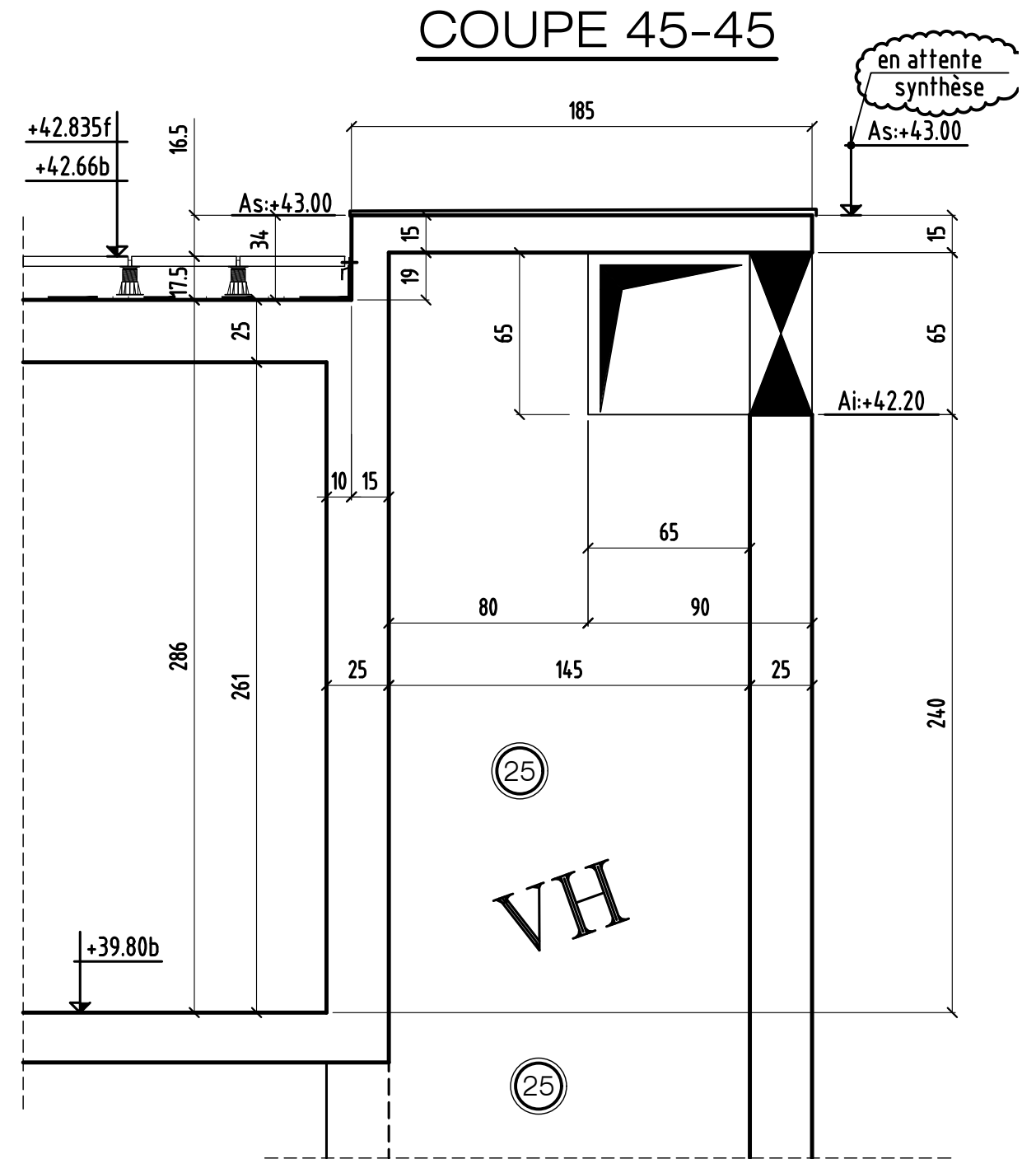
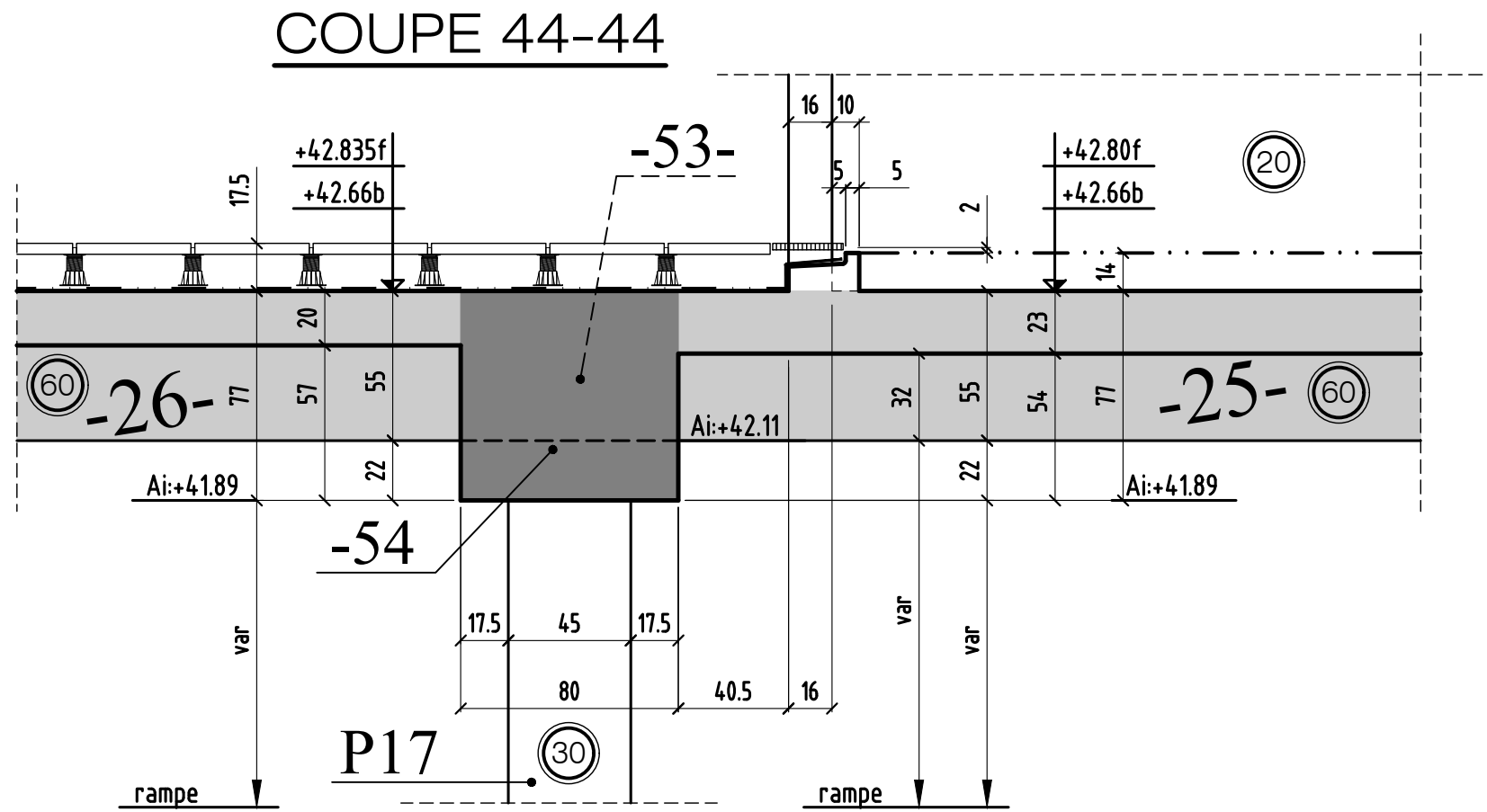

# COUPE 46-46

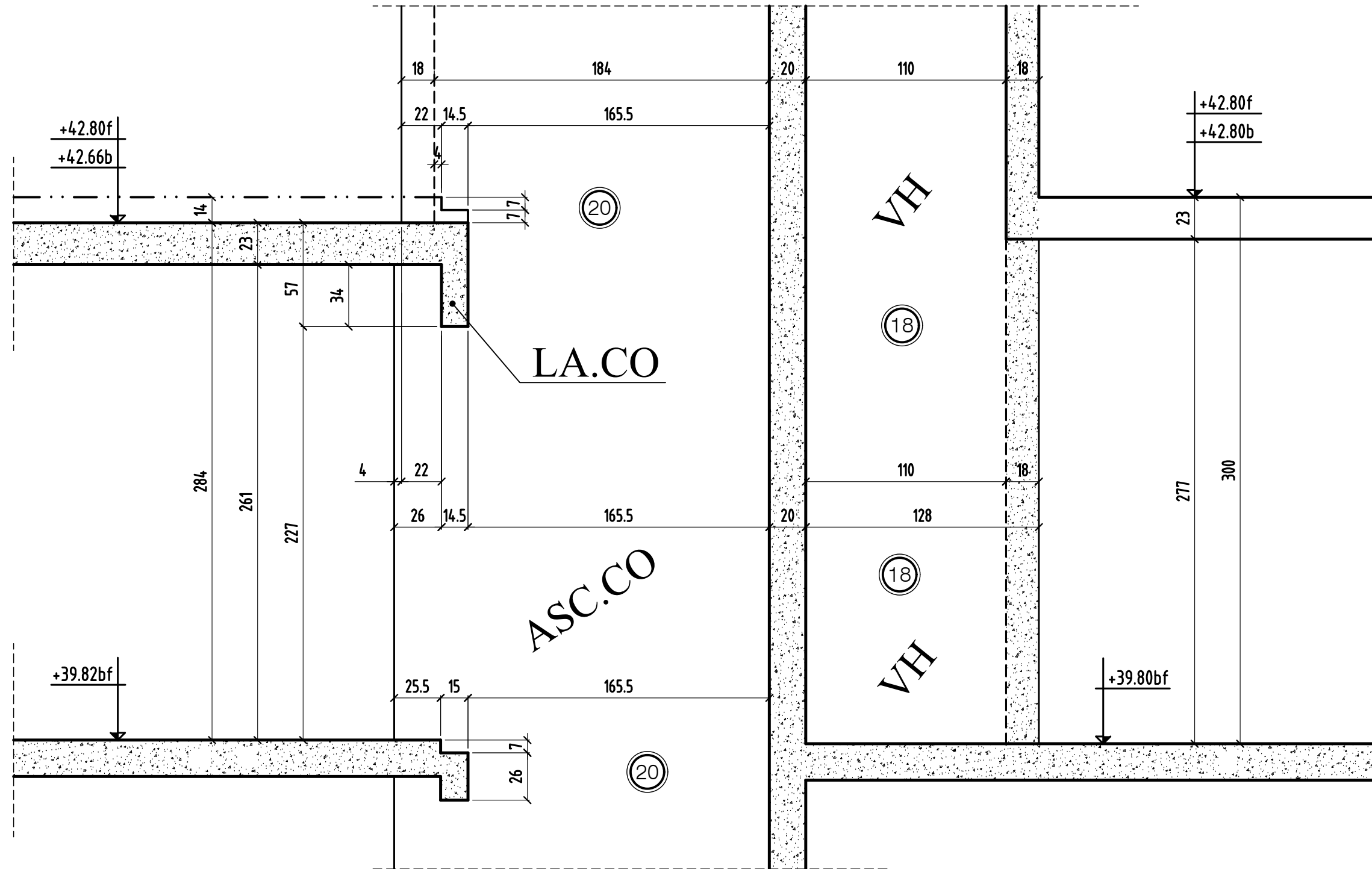

coupe 46-46

MODIFICATIONS	A		AFFAIRE:bâtiment CO	Cahier CO-31
0	B		Ech:1/25	16

# Coupe A-A

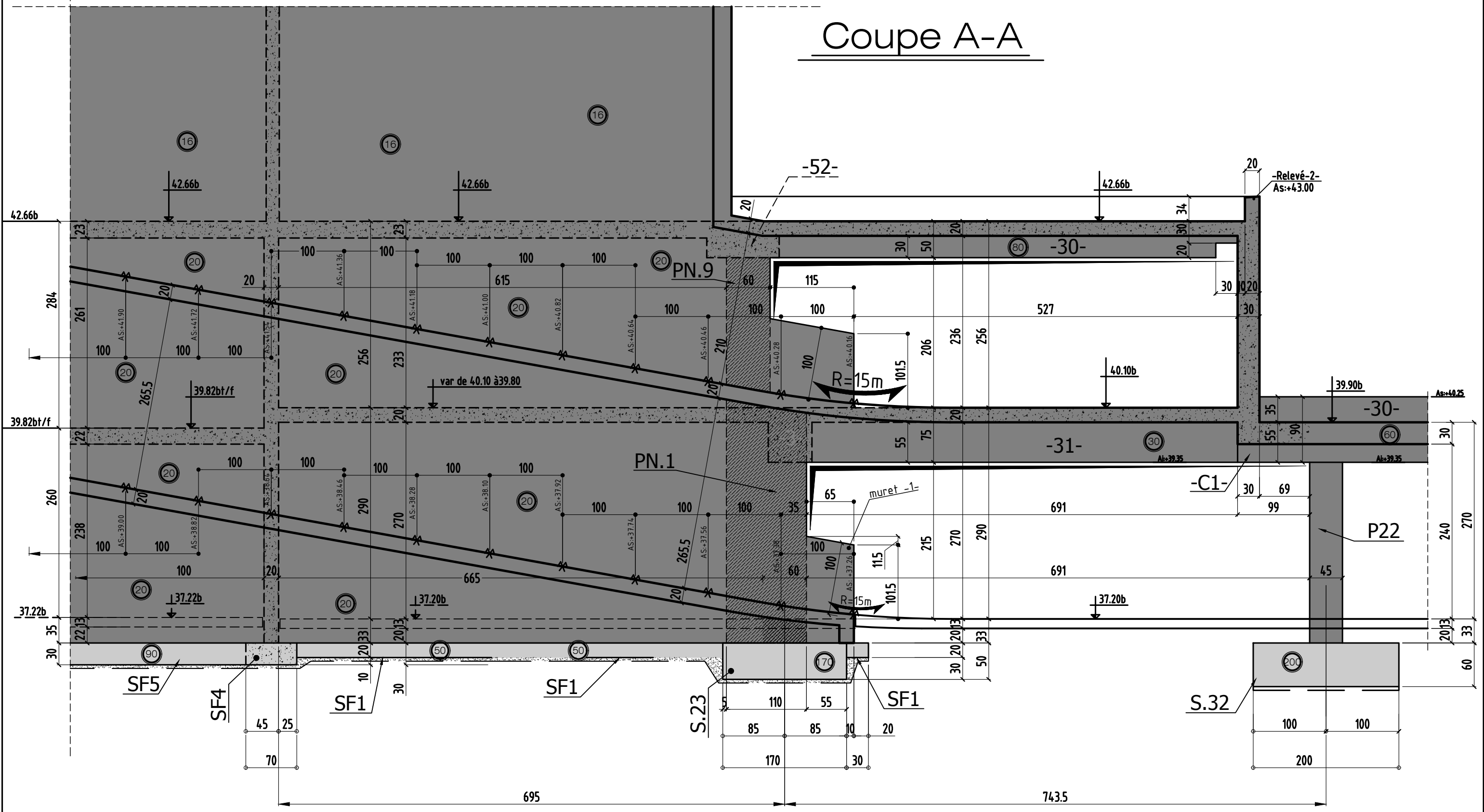

coupe A-A

MODIFICATIONS		A	AFFAIRE:bâtiment C0	Cahier C0-31
0		B	Ech:1/50	17

# COUPE B-B

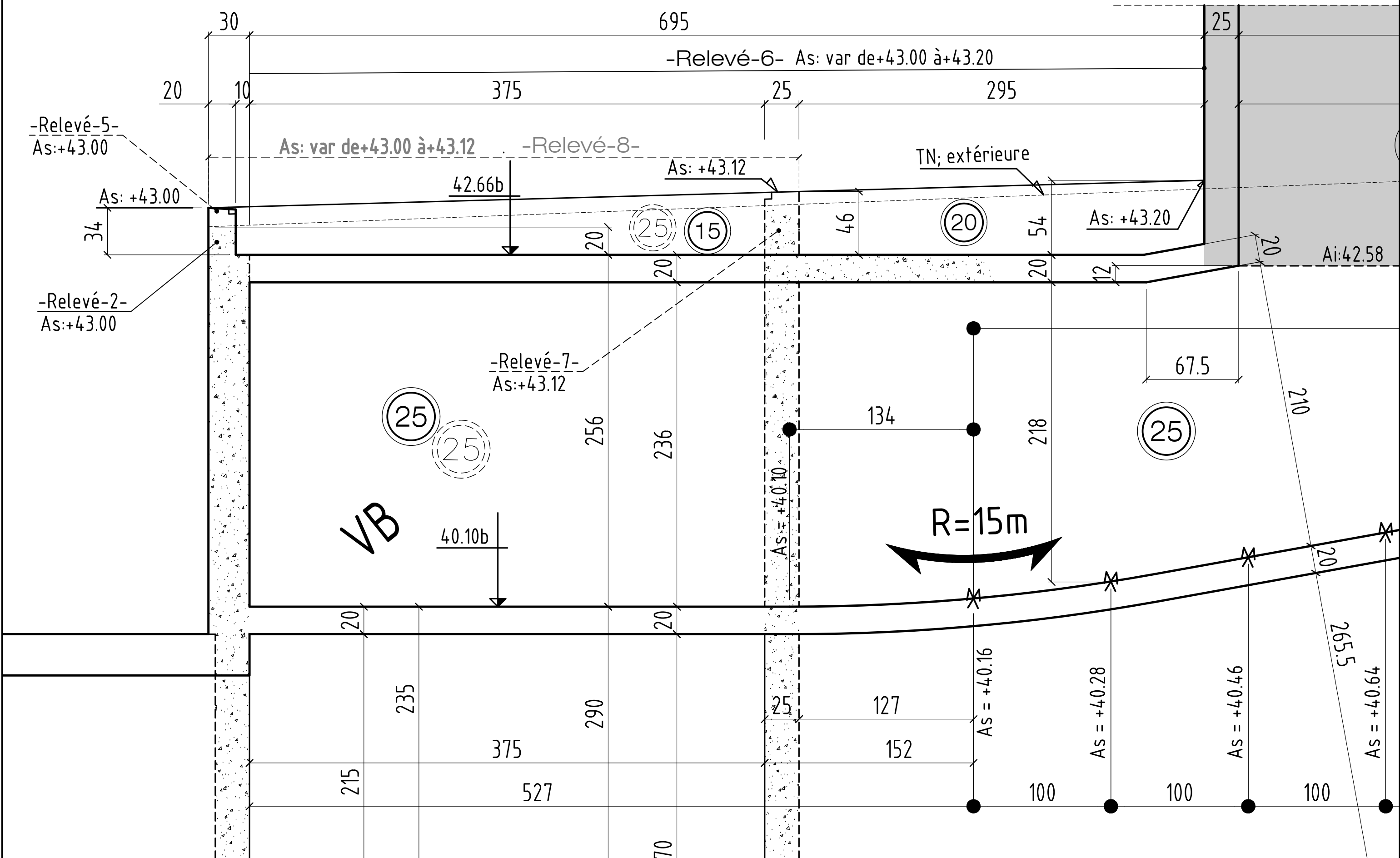

coupe B-B

0	MODIFICATIONS	A	AFFAIRE: bâtiment CO	Cahier CO-31
		B		