

NOTA : Plancher haut commerces  
 prévoir Les isolants en fond de coffrage sous les planchers béton

RESERVATIONS DANS LES VOILES			
N°	A.I	TYPE	Dim(cm) lxht ou Ø
15	42.11	PB	30x30ht
16	42.11	PB	30x30ht
17	42.11	PB	30x30ht
18	42.69	PB	Ø16
19	42.96	PB	Ø16
20	42.50	PB	20x20ht
21	42.11	PB	40x30ht
22	42.13	PB	30x30ht
23	42.18	PB	30x25ht
24	42.16	PB	30x25ht
25	41.35	PB	35x35ht

RESERVATIONS DANS LES POUTRES			
N°	A.I	TYPE	Dim(cm) lxht ou Ø
E	42.81	PB	Ø20
F	42.83	PB	Ø20
H	42.73	PB	Ø20
I	42.83	PB	Ø20
J	42.86	PB	Ø20
K	42.78	PB	Ø20
L	42.79	PB	Ø20
M	42.88	PB	Ø20

**NOTA :**  
 ZONE COUPE

VOIR PLAN N° : C.27 - Coupes et détails

**COUPE FEU:** PLANCHERS CF = 2 HEURE  
 STABLE AU FEU: VERTICAUX SF = 2 HEURE

**SURCHARGES D'EXPLOITATION:**  
 LOGEMENTS: 150 DaN/m2  
 PARTIES COMMUNES: 250 DaN/m2  
 JARDINS ET TERRASSES: 250 DaN/m2  
 BALCONS: 350 DaN/m2

**CHARGES PERMANENTES:**  
 LOGEMENTS (Revetements + cloisons): 150 DaN/m2  
 JARDINS ( Terres saturées ): 2000 DaN/m3

**PRECONISATIONS DES BETONS:**  
 NORME NF EN 206-1 en vigueur  
 Béton apparent: XC1 C25/30 Fc28 = 25 Mpa  
 Béton Voiles sous terre: XF1 C25/30 Fc28 = 25 MPa  
 Gros Béton: XF1 C16/20 Fc28 = 20 MPa

sauf cas contraires indiqués sur la vue en plan

Repérage des voiles contre terres

**Eléments de structure :**

- Béton porteur
- Poteaux noyés
- Poteaux porteurs
- Poutres béton armé
- Béton Non Porteur
- Maçonnerie Pleine Porteuse
- Maçonnerie Creuse Porteuse
- Maçonnerie Pleine Non Porteuse
- Maçonnerie Creuse Non Porteuse
- Béton Préfabriqué
- Impact des voiles béton porteur
- Impact garde-corps et relevés BA

**Complexes et revêtements :**

- Gros Béton et recharges
- Dalles sur plots
- Terre, pelouses
- Jardinières

± : Environ DAP : Dalle Alvéolaire Précontrainte  
 VAR : Variable S.L.C. : Selon la Cote  
 Lg : Longrine Tr : Trumeau R : Raidisseur  
 C : Chevêtre M : Massif V : Voile  
 Ch : Chainage P : Poteau Vct : Voile contre terre  
 L : Linteau PN : Poteau noyé T : Tirant  
 Lib : Libage S : Semelle PV : Amorce Poutre V  
 BN : Bande-noyée SF : Semelle filante PV : Poutre-voile

**CHOISY LE ROI 94600**

**CONSTRUCTION D'UN ENSEMBLE DE 107 LOGEMENTS SOCIAUX & commerces**

94600 CHOISY LE ROI  
 ILOT 1

<b>MAITRE D'OEUVRE</b> CITE ARCHITECTURE 11 RUE FLATTERS 75005 PARIS ☎ 01.48.28.44.10 ☎ 01.48.28.44.18	<b>MAITRE D'OUVRAGE</b> BOUYGUES IMMOBILIER 27, avenue des Murs du Parc 94300 Vincennes ☎ 01.58.64.53.54 ☎ 01.58.64.53.03
<b>BUREAU DE CONTROLE</b> QUALICONSULT 127/121 chemin des Bassins 93035 CRETEIL ☎ 01.49.56.06.00 ☎ 01.48.71.65.61	<b>ENTREPRISE G.O.</b> M.T.R. 9, rue René Cassin 77173 CHEVRY-COSSIGNY ☎ 01.60.62.32.00 ☎ 01.60.62.32.01

**VUE EN PLAN (Vue de dessous) - COFFRAGE PH RDC batiment A**

ind.	date	modifications
0	06-12-17	1 ère diffusion.
A	10-01-18	MISE A JOUR GENERAL
B	02-04-18	MISE A JOUR VISA MOE
C	23-04-18	MISE A JOUR VISA MOE
D	26-04-18	MISE A JOUR AS POTEAUX P110à P115 SUIVANT DETAILS PLATINES
E	04-05-18	MISE A JOUR AS POTEAUX SUIVANT VISA SUR DETAILS PLATINES

DOSSIER	PLAN	APD
294	C.09	PRO
Ingenieur	Projeteur	Date
	H.B.E	06/12/17
		Echelle
		1/50



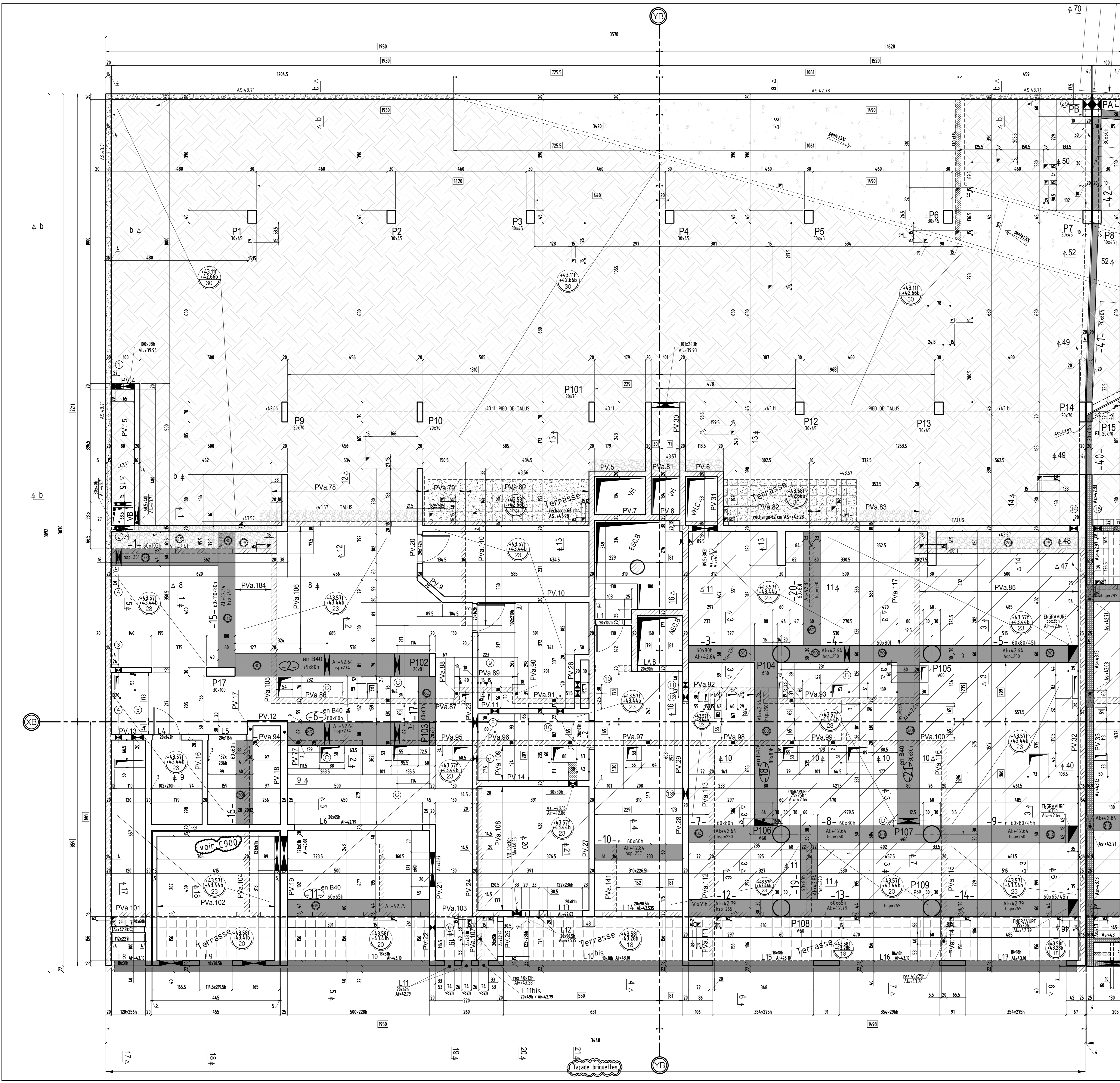

NOTA : Plancher haut commerces  
prevoir Les isolants en fond de coffrage sous les planchers béton

RESERVATIONS DANS LES VOILES

N°	A.I	TYPE	Dim(cm) lxht ou Ø
1	42.03	PB	30x30ht
2	42.11	PB	30x30ht
3	42.72	PB	25x25ht
4	42.77	PB	25x25ht
5	42.88	PB	44x25ht
6	42.75	PB	25x25ht
7	42.69	PB	25x25ht
8	42.43	PB	60x30ht
9	42.50	PB	30x30ht
10	42.90	EL	25x25ht
11	42.50	PB	20x30ht
12	42.50	PB	30x30ht
13	42.51	PB	53x25ht
14	42.11	PB	30x30ht

RESERVATIONS DANS LES POUTRES

N°	A.I	TYPE	Dim(cm) lxht ou Ø
A	42.60	PB	Ø20
B	42.89	PB	Ø20
C	42.94	PB	Ø20
D	42.80	PB	Ø20

VOIR PLAN N° : C.08 - Coupes et détails

COUPE FEU : PLANCHERS CF = 2 HEURE  
STABLE AU FEU : VERTICAUX SF = 2 HEURE

**SURCHARGES D'EXPLOITATION:**  
 LOGEMENTS : 150 DaNm<sup>2</sup>  
 PARTIES COMMUNES : 250 DaNm<sup>2</sup>  
 JARDINS ET TERRASSES : 250 DaNm<sup>2</sup>  
 BALCONS : 350 DaNm<sup>2</sup>

**CHARGES PERMANENTES:**  
 LOGEMENTS (Revetements + cloisons) : 150 DaNm<sup>2</sup>  
 JARDINS (Terres saturées) : 2000 DaNm<sup>3</sup>

**PREDONISATIONS DES BETONS:**  
 NORME NF EN 206-1 en vigueur  
 Béton apparent : XC1 C25/30 Fc28 = 25 Mpa  
 Béton Voiles sous terre : XF1 C25/30 Fc28 = 25 MPa  
 Gros Béton : XF1 C16/20 Fc28 = 20 MPa  
 sauf cas contraire indiqués sur la vue en plan

Rapéage des voiles contre terres

**Eléments de structure:**  
 Béton porteur  
 Poteaux noyés  
 Poteaux béton armé  
 Béton Non Porteur  
 Maçonnerie Plaine Porteuse  
 Maçonnerie Creuse Porteuse  
 Maçonnerie Plaine Non Porteuse  
 Maçonnerie Creuse Non Porteuse  
 Béton Préfabriqué  
 Impact des voiles béton porteur  
 Impact garde-corps et relevés BA

**Complexes et revêtements:**  
 Gros Béton et recharges  
 Dalles sur plots  
 Terre, pelouses  
 Jardinières

**Legende:**  
 A. : Environ DAP : Dalle Alvéolaire Précontrainte  
 VAR : Variable S.L.C. : Selon la Cote  
 Lg : Longrine Tr : Trameau R : Raidisseur  
 C : Chevêtre M : Massif V : Voile  
 Ch : Châtrage P : Poteau Vct : Voile contre terre  
 L : Linteau PK : Poteau noyé T : Trans  
 Lib : Librage S : Semelle Pv.a : Almoira Poutre V  
 BN : Bande-noyée SF : Semelle fixée PV : Poutre-voile

CHOISY LE ROI 94600  
**CONSTRUCTION D'UN ENSEMBLE**  
**DE 107 LOGEMENTS SOCIAUX & commerces**  
 94600 CHOISY LE ROI  
 ILOT 1

<b>MAITRE D'OEUVRE</b> <b>CITE ARCHITECTURE</b> 11 RUE PLATERS 75005 PARIS ☎ 01.48.28.44.19 ☎ 01.48.28.44.18	<b>MAITRE D'OUVRAGE</b> <b>BOUYGUES IMMOBILIER</b> 27, avenue des Murs du Parc 94300 Vincennes ☎ 01.56.64.53.54 ☎ 01.56.64.53.03
<b>BUREAU DE CONTROLE</b> <b>QUALICONSULT</b> 127/121 chemin des Bassins 93035 CRETEIL 78190 - TRAPPES CREDEX ☎ 01.49.56.06.00 ☎ 01.48.71.85.81	<b>ENTREPRISE G.O.</b> <b>M.T.R</b> 9, rue René Cassin 77173 CHEVRY-COSSIGNY ☎ 01.60.62.32.00 ☎ 01.60.62.32.01

VUE EN PLAN (vue de dessous) - COFFRAGE  
 PH RDC batiment B

ind.	date	modifications
0	06-12-17	1 ère diffusion
A	20-12-17	MISE A JOUR FACADE BRIQUETTE
B	26-03-18	MISE A JOUR SUIVANT VISA MDE
C	23-04-18	MISE A JOUR SUIVANT VISA MDE

DOSSIER	PLAN	APD
294	C.07	IND. PRO
Ingenieur	Projeteur	DATE
H.D.B.	06/12/17	1/50



SOUS JOINT

DESSUS JOINT

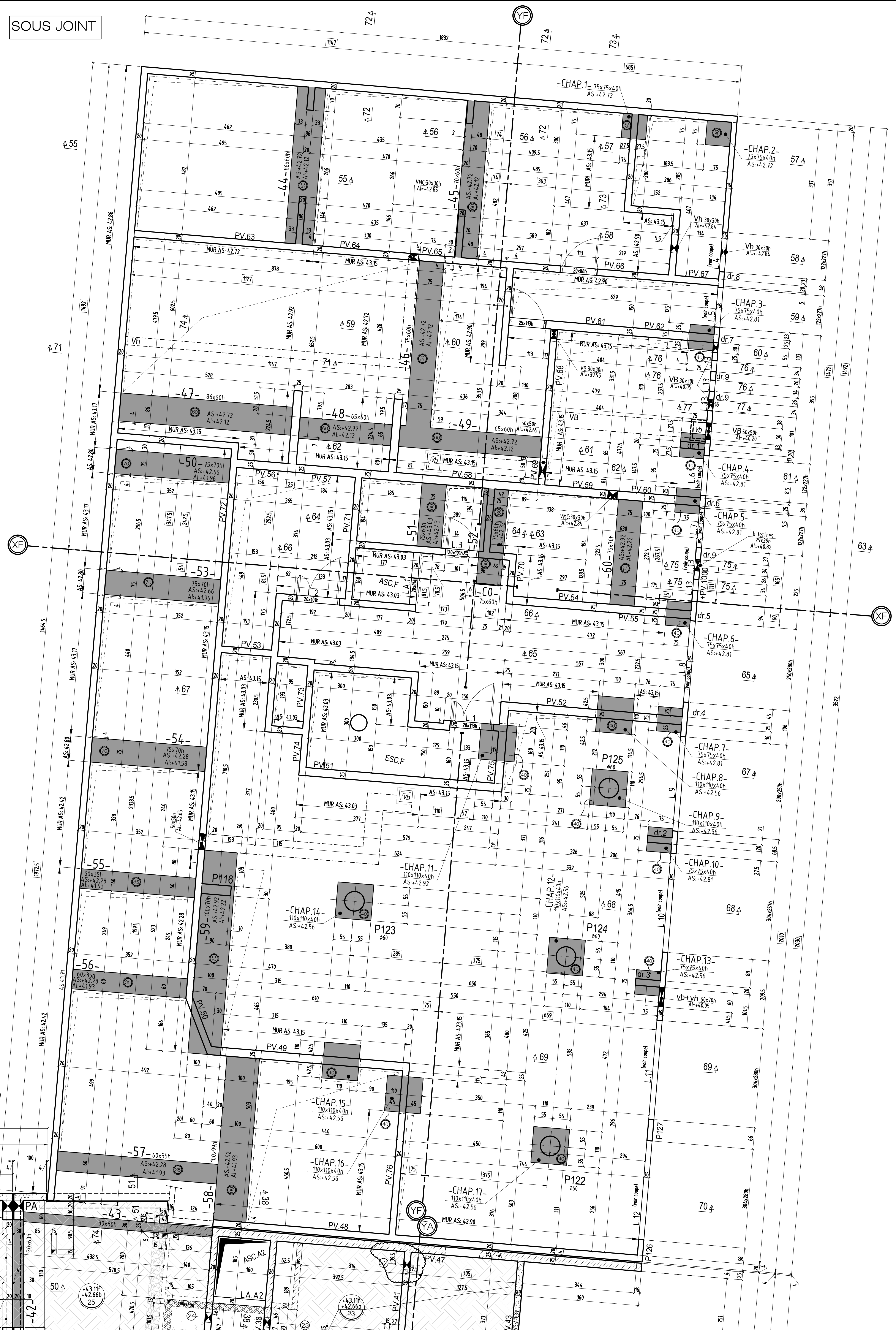

NOTA : Plancher haut commerces  
prevoir Les isolants en fond de coffrage sous les planchers béton

VOIR PLAN N° : C.34-C35 - Coupes et détails

<p><b>COUPE FEU</b> PLANCHERS CF = 2 HEURE STABLE AU FEU VERTICAUX SF = 2 HEURE</p> <p><b>SURCHARGES D'EXPLOITATION:</b> LOGEMENTS : 150 DaN/m<sup>2</sup> PARTIES COMMUNES : 250 DaN/m<sup>2</sup> JARDONS ET TERRASSES : 200 DaN/m<sup>2</sup> BALCONS : 300 DaN/m<sup>2</sup></p> <p><b>CHARGES PERMANENTES :</b> LOGEMENTS (Revêtements + cloisons) : 100 DaN/m<sup>2</sup> JARDONS (Terre saturée) : 200 DaN/m<sup>2</sup></p> <p><b>PRECONISATIONS DES BETONS:</b> NORME NF EN 206-1 en vigueur Béton apparent : XC1 C25/30 Fc28 = 25 Mpa Béton Voies sous terre : XF1 C25/30 Fc28 = 25 Mpa Gros Béton : XF1 C16/20 Fc28 = 20 Mpa sauf cas contraire indiqués sur la vue en plan</p> <p><b>Routage des voiles contre terre</b></p>	<p><b>Éléments de structure :</b></p> <ul style="list-style-type: none"> <li>Béton porteur</li> <li>Poteaux noyers</li> <li>Poteaux porteurs</li> <li>Plottes béton armé</li> <li>Béton Non Porteur</li> <li>Maçonnerie Pleine Porteuse</li> <li>Maçonnerie Pleine Non Porteuse</li> <li>Maçonnerie Creuse Non Porteuse</li> <li>Béton Préfabriqué</li> <li>Impact des voiles béton porteur</li> <li>Impact garde-corps et relevés BA</li> </ul> <p><b>Compresses et revêtements :</b></p> <ul style="list-style-type: none"> <li>Grais Béton et recharges</li> <li>Dalles sur plots</li> <li>Tapis, pavés</li> <li>Jardinières</li> </ul> <p><b>Abbréviations :</b></p> <ul style="list-style-type: none"> <li>A : Enlèvement</li> <li>VAR : Variante</li> <li>C : Chevre</li> <li>CH : Châlage</li> <li>Li : Libage</li> <li>BN : Bande-noyée</li> <li>DAP : Dalle Alvéolaire Précontrainte</li> <li>S.L.C : Selon la Cote</li> <li>TC : Tronçon</li> <li>M : Massif</li> <li>P : Poutre</li> <li>PN : Poutre Noyée</li> <li>S : Semelle</li> <li>SF : Surville Sautee</li> <li>R : Radier</li> <li>V : Voile</li> <li>Vol : Voile contre terre</li> <li>T : Tranch</li> <li>PVA : Armure Poutre-V</li> <li>PV : Poutre-voile</li> </ul>
--	--

CHOISY LE ROI 94600  
**CONSTRUCTION D'UN ENSEMBLE**  
DE 107 LOGEMENTS SOCIAUX & commerces  
94600 CHOISY LE ROI  
LOT 1

<p>MAITRE D'OEUVRE <b>CITE ARCHITECTURE</b> 11 RUE PLATERS 75005 PARIS ☎ 01.48.28.44.10 ☎ 01.48.28.44.18</p>	<p>MAITRE D'OUVRAGE <b>BOUYGUES IMMOBILIER</b> 27, avenue des Murs du Parc 94300 Vincennes ☎ 01.58.64.53.84 ☎ 01.58.64.53.85</p>
<p>BUREAU DE CONTRÔLE <b>QUALICONSULT</b> 127/131 Chemin des Bassins 91015 CITESEL ☎ 01.49.56.06.00 ☎ 01.48.71.85.61</p>	<p><b>ENTREPRISE G.O.</b> M.T.R. 9, rue René Cassin 77173 CHEVRY-COSSIGNY ☎ 01.60.62.32.00 ☎ 01.60.62.32.01</p>

VUE EN PLAN (Vue de dessus) - COFFRAGE  
PH RDC bâtiment F

ind.	date	modifications
D	15-02-18	1 ère diffusion
A	11-04-18	MISE A JOUR SUIVANT VISA ET SUIVANT RAJOUT LOGGARDIEN
B	25-04-18	MISE A JOUR SUIVANT VISA
C	07-05-18	MISE A JOUR REPERE POTEAUX

DOSSIER	PLAN	APD
294	C.33	IND.
Intégrer	Intégrer	EXE
		DOC
		Ende
		1/30



CHOISY LE ROI

94600

**CONSTRUCTION D'UN ENSEMBLE  
DE 107 LOGEMENTS SOCIAUX & commerces  
bts: A & B & F**

94600 CHOISY LE ROI  
ILOT 1

<b>MAITRE D' OEUVRE</b>	<b>MAITRE D'OUVRAGE</b>
<b>CITE ARCHITECTURE</b> 11 RUE FLATERS 75005 PARIS ☎: 01.48.28.44.10 ☎: 01.48.28.44.18	<b>BOUYGUES IMMOBILIER</b> 27, avenue des Murs du Parc 94300 Vincennes ☎: 01.58.64.53.54 ☎: 01.58.64.53.03
<b>BUREAU DE CONTROLE</b>	<b>ENTREPRISE G.O.</b>
<b>QUALICONSULT</b> 127/121 chemin des Bassins 93035 CRETEIL ☎: 01.49.56.06.00 ☎: 01.48.71.85.81	<b>M.T.R</b> 9, rue René Cassin 77173 CHEVRY-COSSIGNY ☎: 01.60.62.32.00 ☎: 01.60.62.32.01

**COFFRAGE - COUPES & DETAILS**  
*Pht RDC*  
*bt: A*

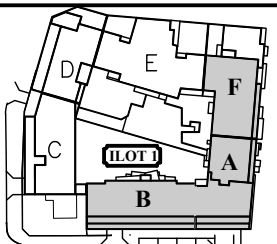

ind.	date	modifications
0	06-12-17	1 ère diffusion.
A	10-01-18	mise a jour général
B	23-04-18	mise a jour suivant visa
C	26-04-18	mise a jour suivant DETAILS PLATINE RECU LE 24-04-18
D	04-05-18	mise a jour suivant VISA SUR DETAILS PLATINE

	DOSSIER		PLAN		APD
	294		C.27		IND.
					EXE
					PRO
					EXE
				DOE	
Ingenieur	Projeteur	Date	Echelle		
	H.B.E	06/12/17	1/25		

# COUPE 22-22

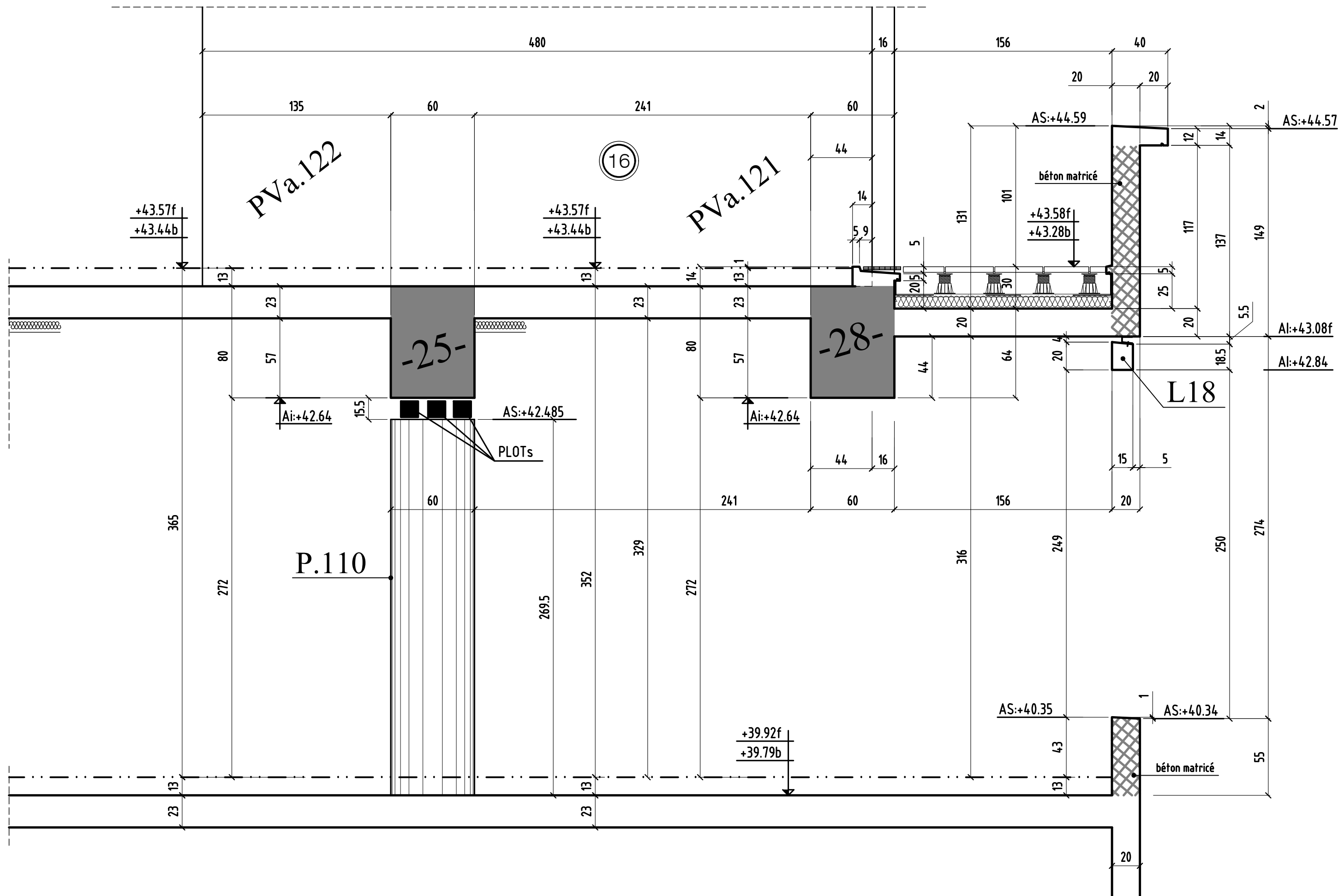

MODIFICATIONS	A	AFFAIRE:294	Cahier C.27
0	B	Ech:1/25	Page 01

# COUPE 23-23

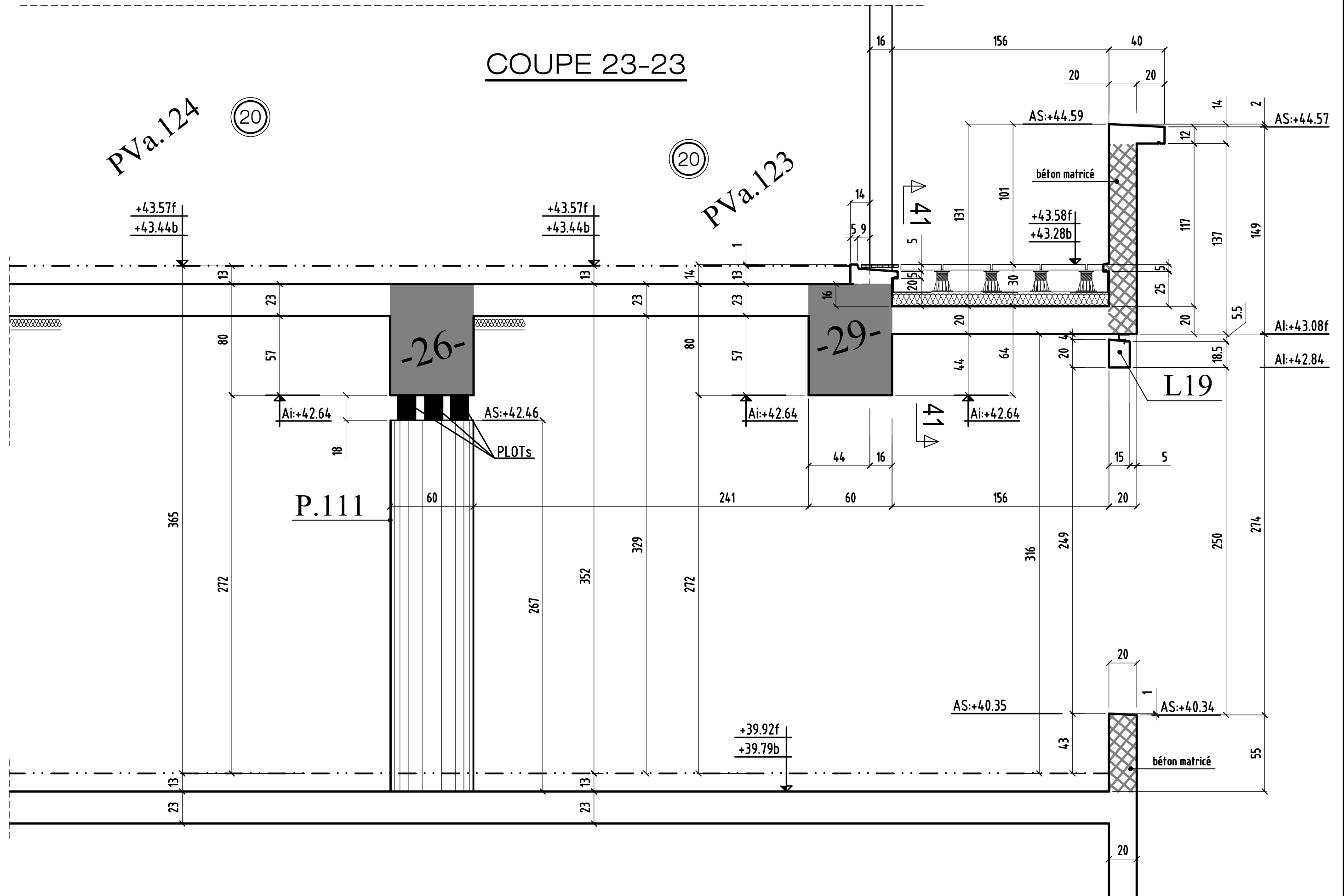

coupe 23-23

0	MODIFICATIONS	A	AFFAIRE:294	Cahier C.27
		B	Ech:1/25	Page 02

# COUPE 24-24

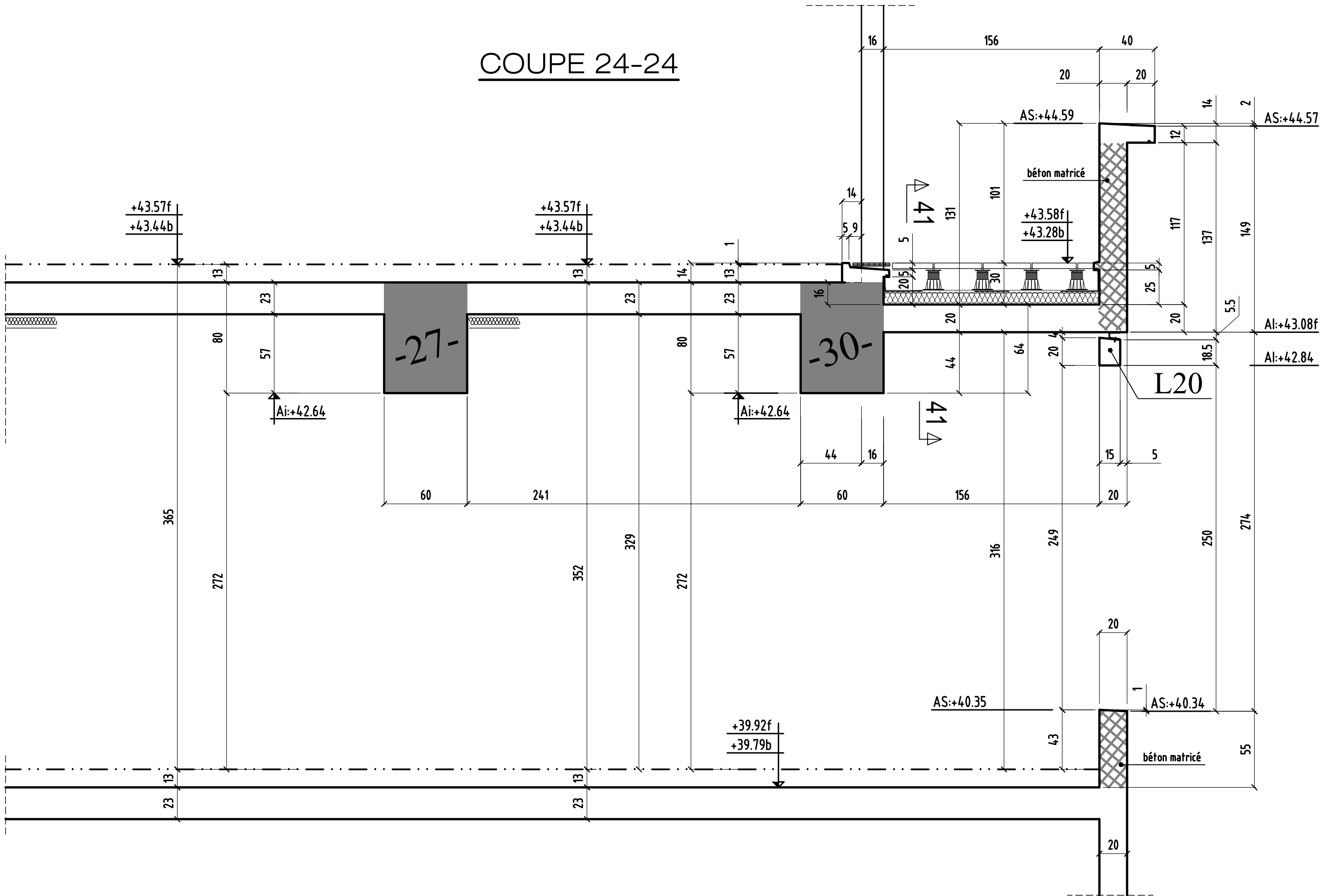

coupe 24-24

0	MODIFICATIONS	A	AFFAIRE:294	Cahier C.27
		B	Ech:1/25	Page 03

# COUPE 25-25

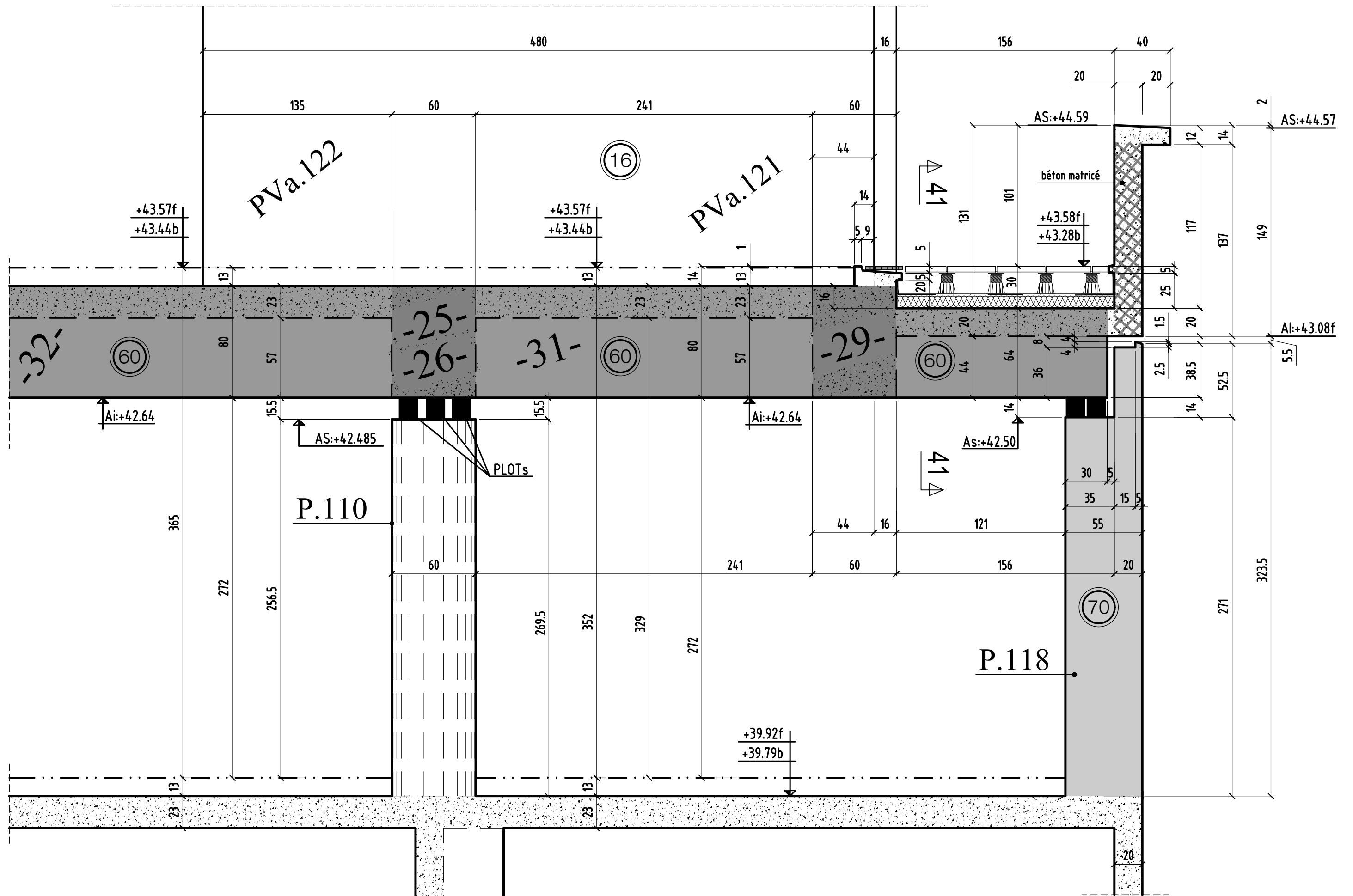

MODIFICATIONS

A  
B

AFFAIRE:294

Cahier C.27

0

Ech:1/25

Page 04



# COUPE 26-26

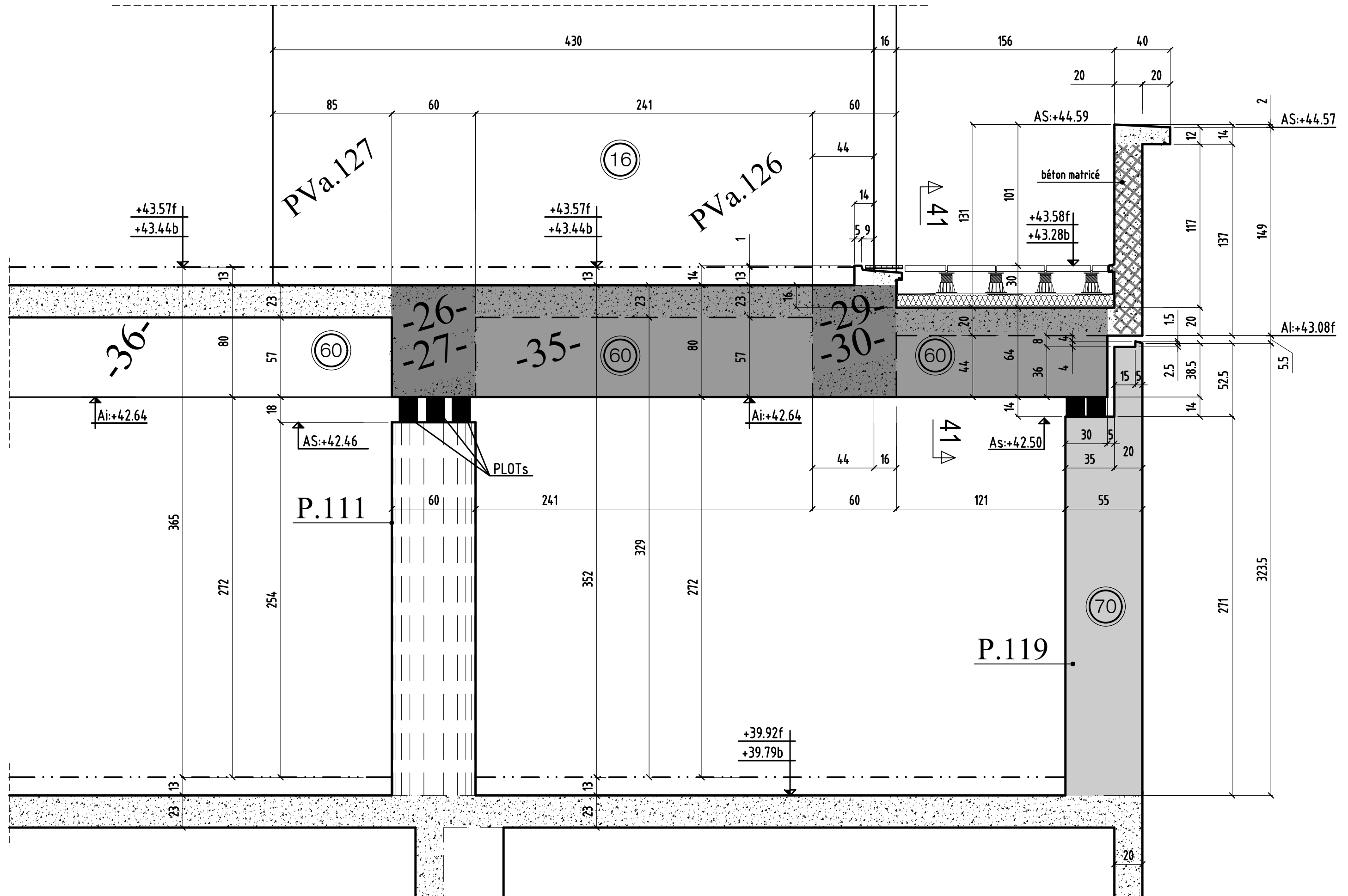

coupe 26-26

MODIFICATIONS

A
B

AFFAIRE:294

Cahier C.27

0

Ech:1/25

Page 05

COUPE 27-27

COUPE 28-28

-23- & -24-  
-32- & -33-

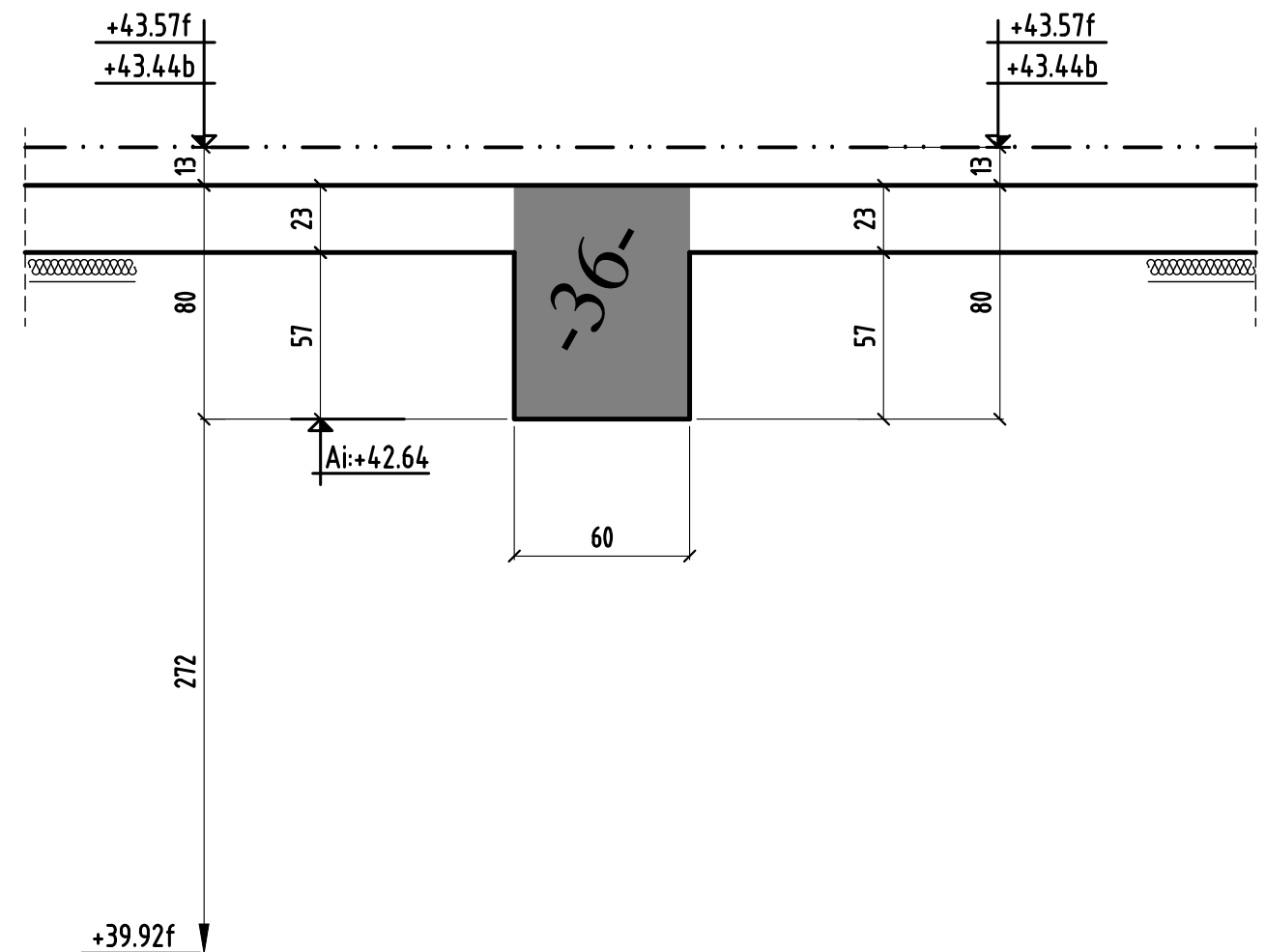
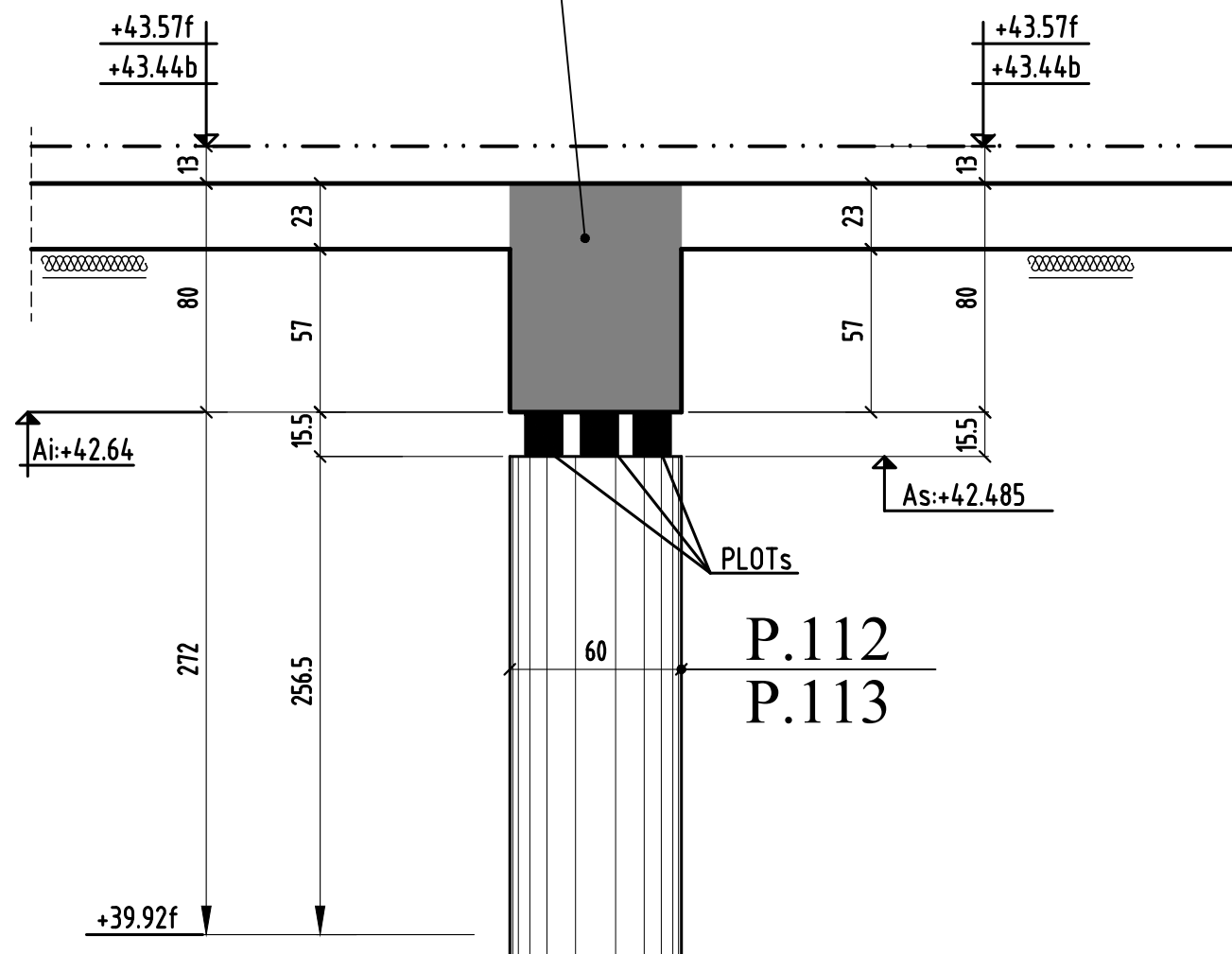



# COUPE 29-29

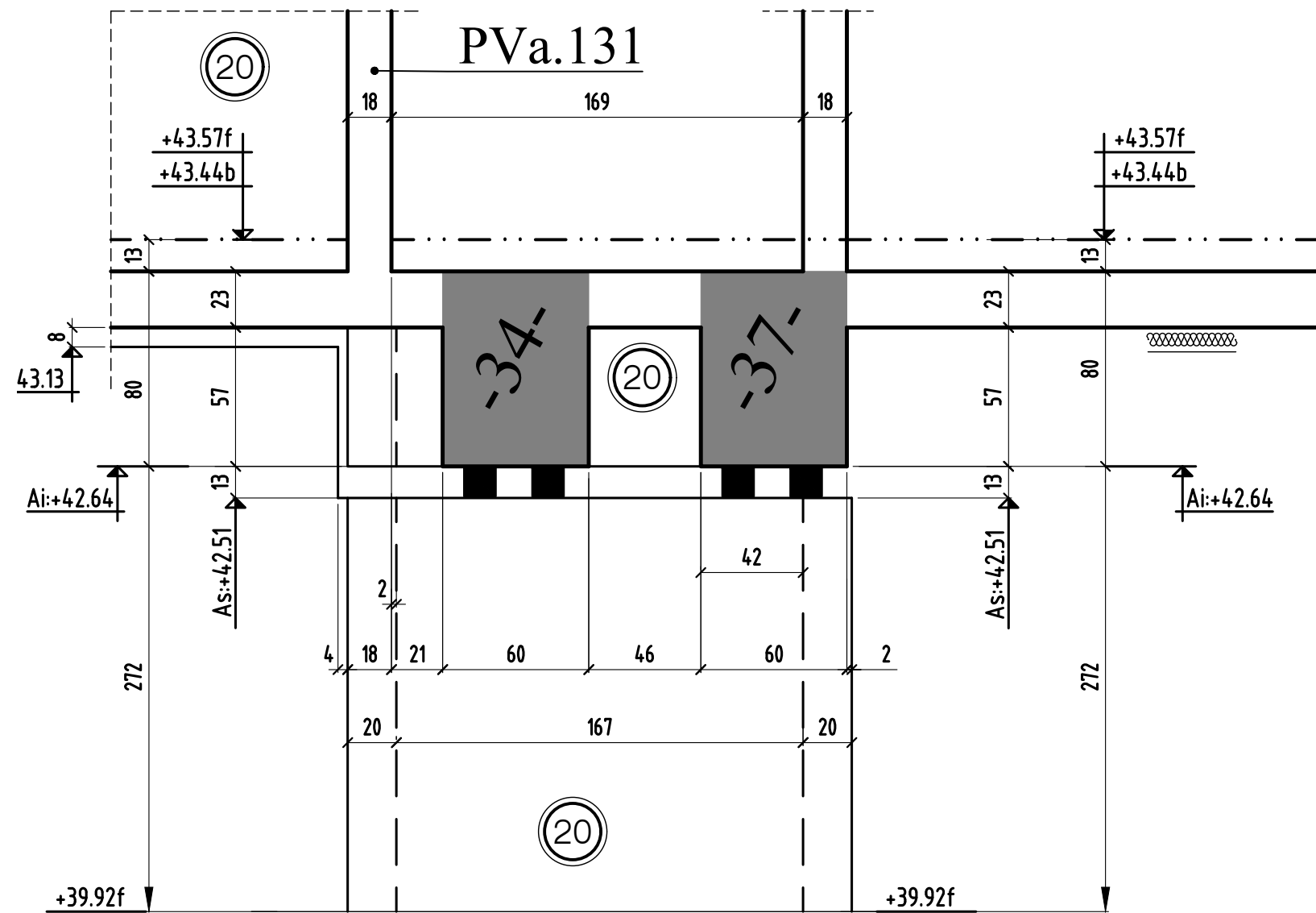

MODIFICATIONS	
0	B

A	
B	

# COUPE 30-30

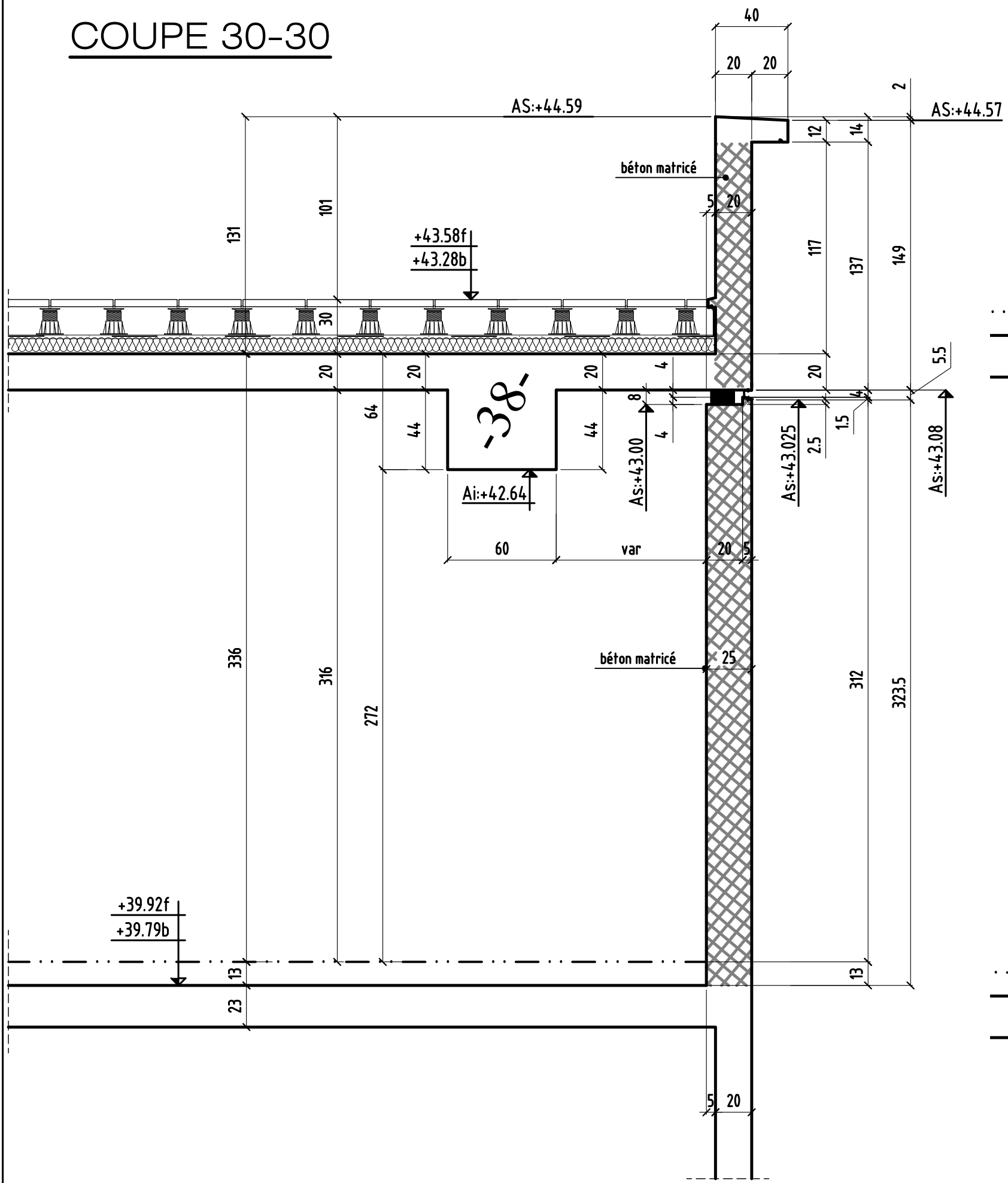

# COUPE 31-31

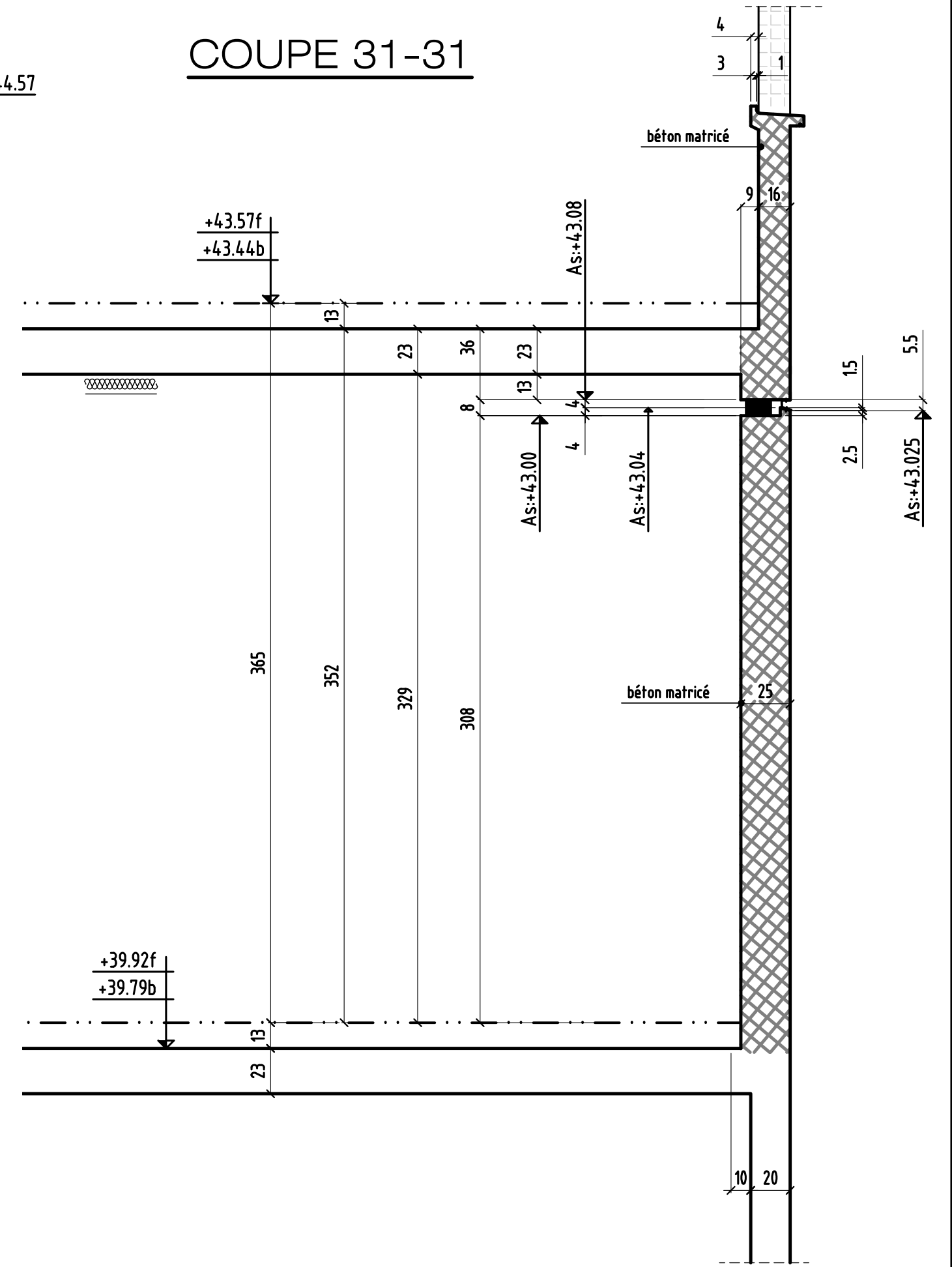

coupe 30-30 & 31-31

0	MODIFICATIONS	A	AFFAIRE:294	Cahier C.27
		B	Ech:1/25	Page 08



# COUPE 32-32

# COUPE 33-33

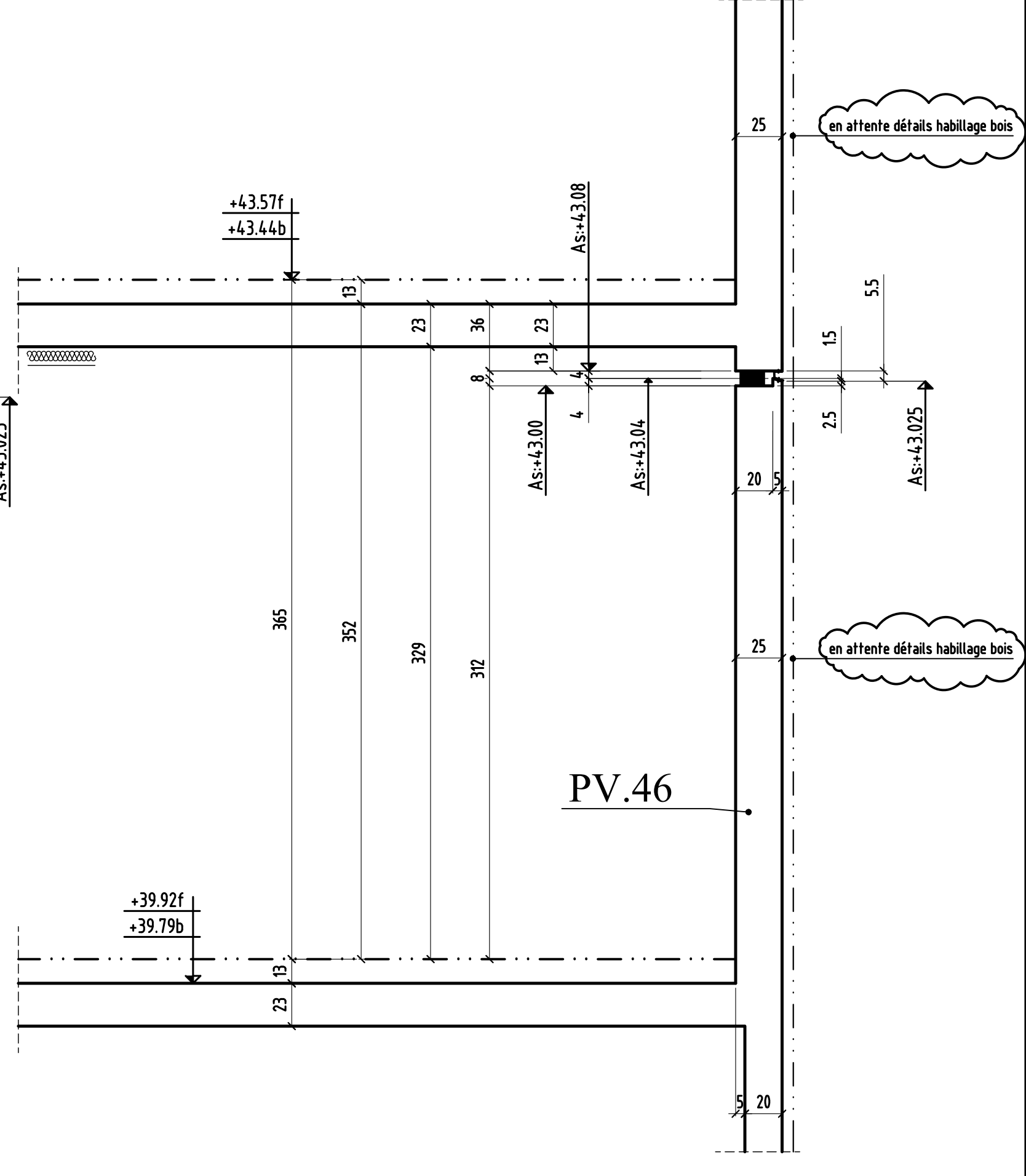
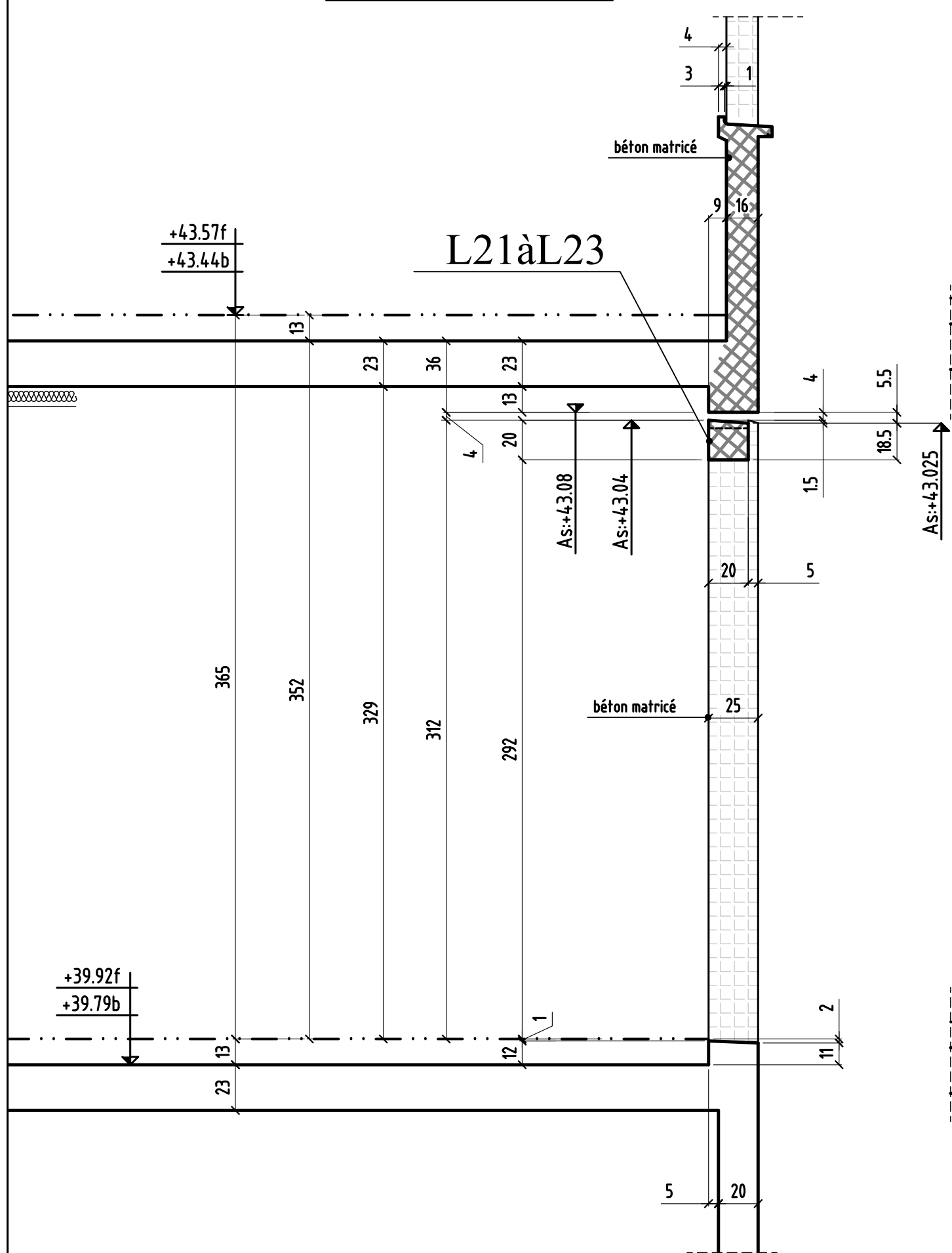

MODIFICATIONS	A	AFFAIRE:294	Cahier C.27
0	B	Ech:1/25	Page 09

# COUPE 34-34

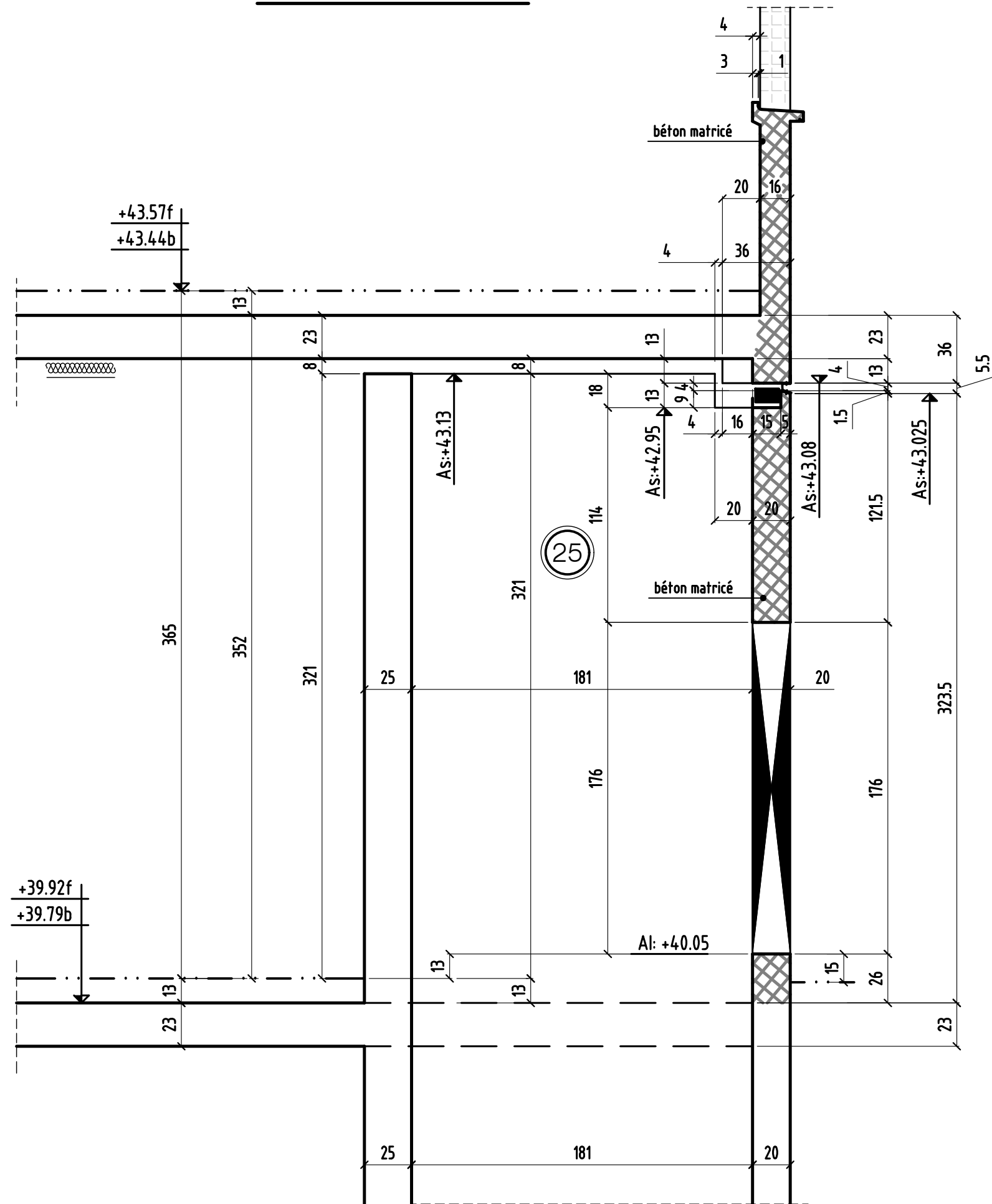

coupe 34-34

MODIFICATIONS

A

AFFAIRE:294

Cahier C.27

0

B

Ech:1/25

Page 10



# COUPE 35-35

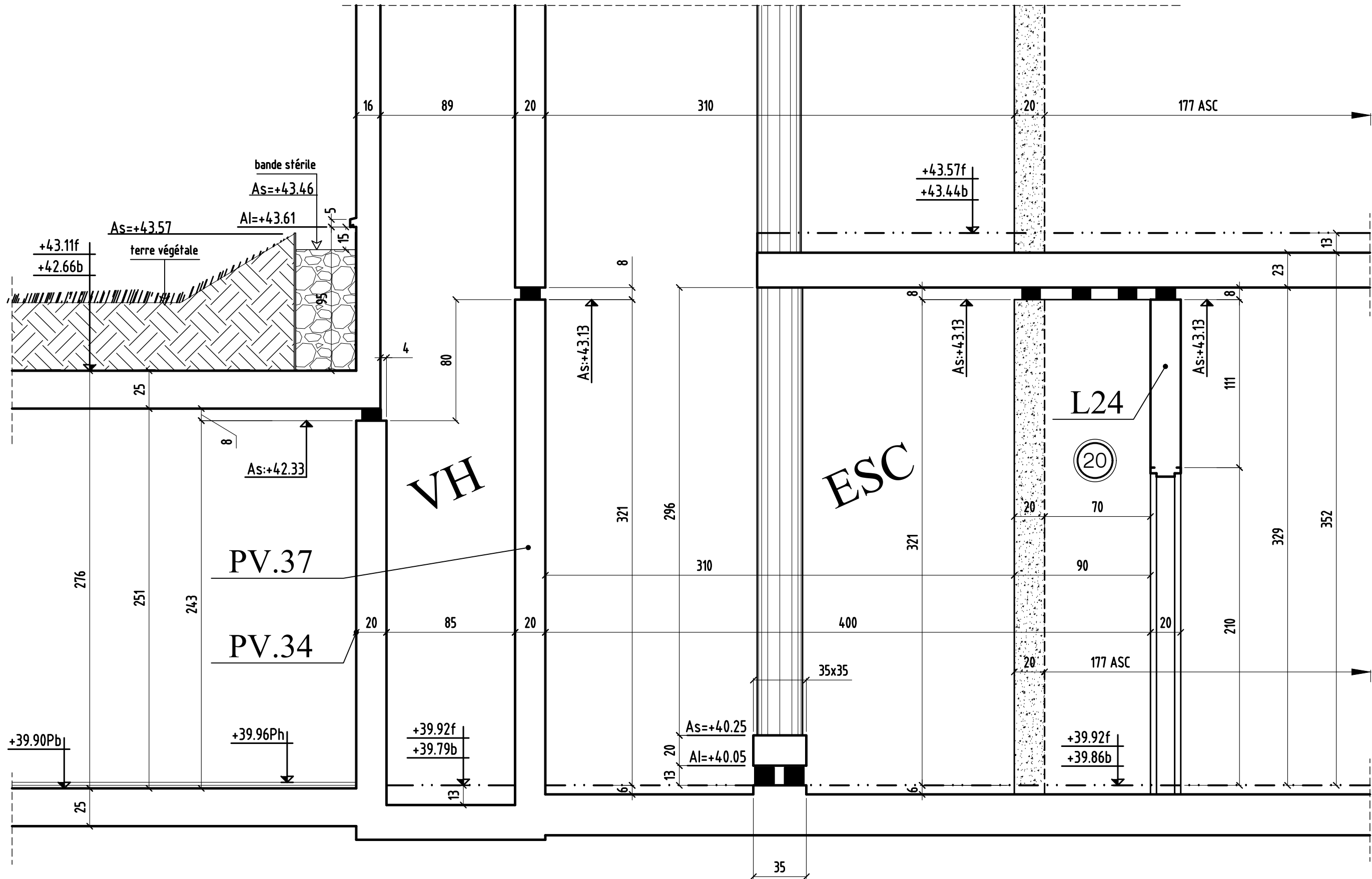

coupe 35-35

MODIFICATIONS

A

AFFAIRE:294

Cahier C.27

0

B

Ech:1/25

Page 11

# COUPE 36-36

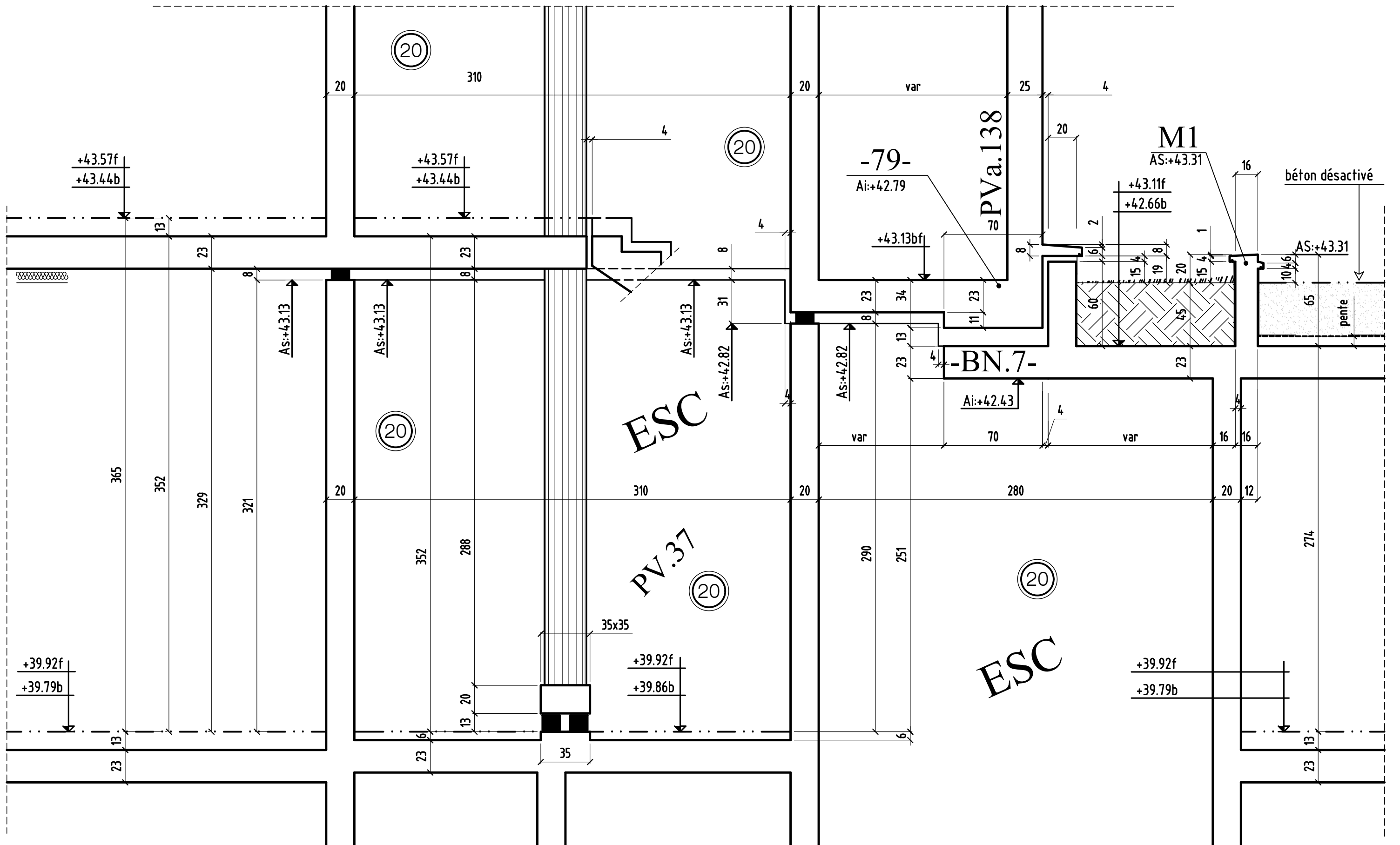

coupe 36-36

MODIFICATIONS

A

AFFAIRE:294

Cahier C.27

0

B

Ech:1/25

Page 12

# COUPE 37-37

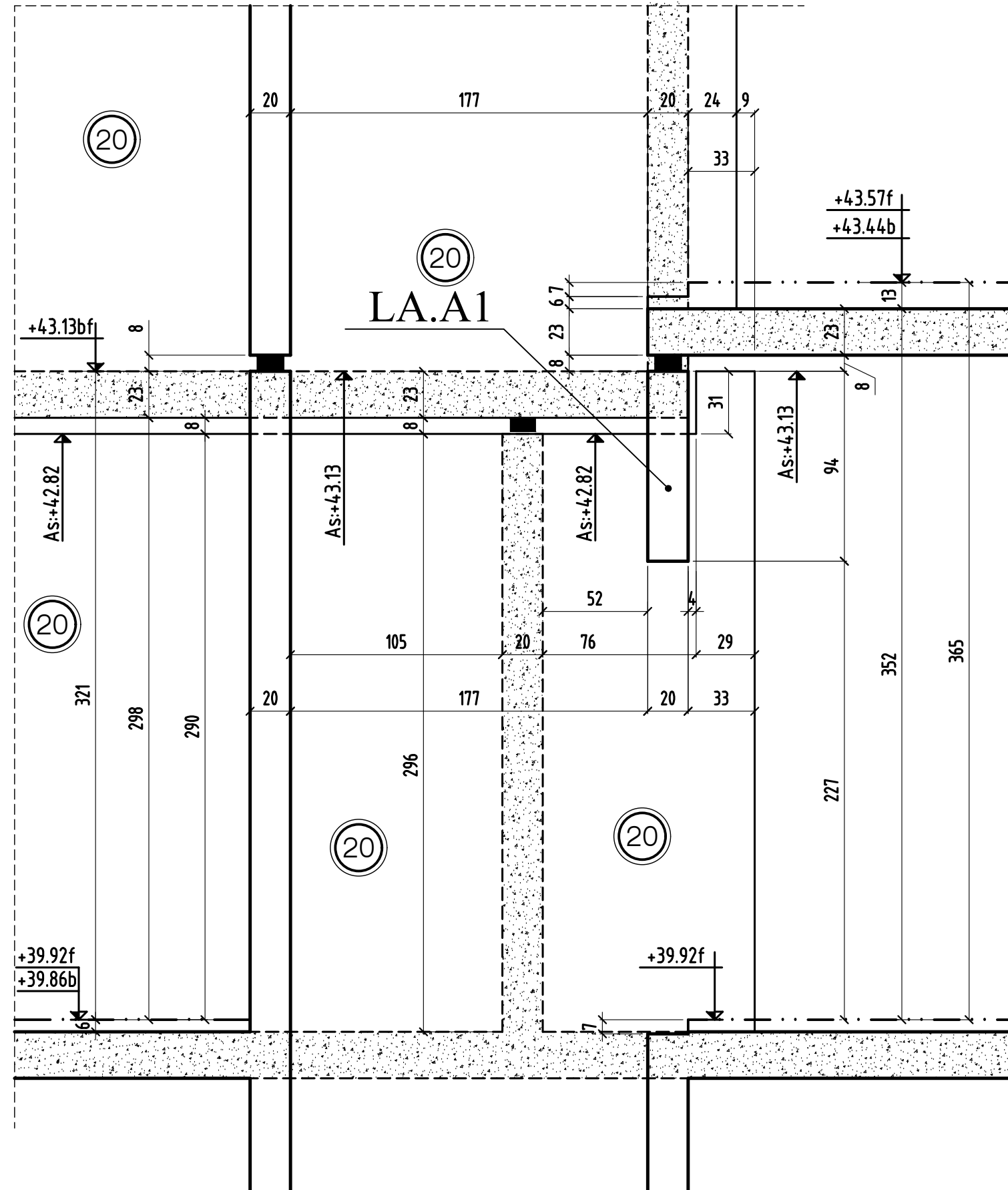

coupe 37-37

MODIFICATIONS

A

AFFAIRE:294

Cahier C.27

0

B

Ech:1/25

Page 13



# COUPE 38-38

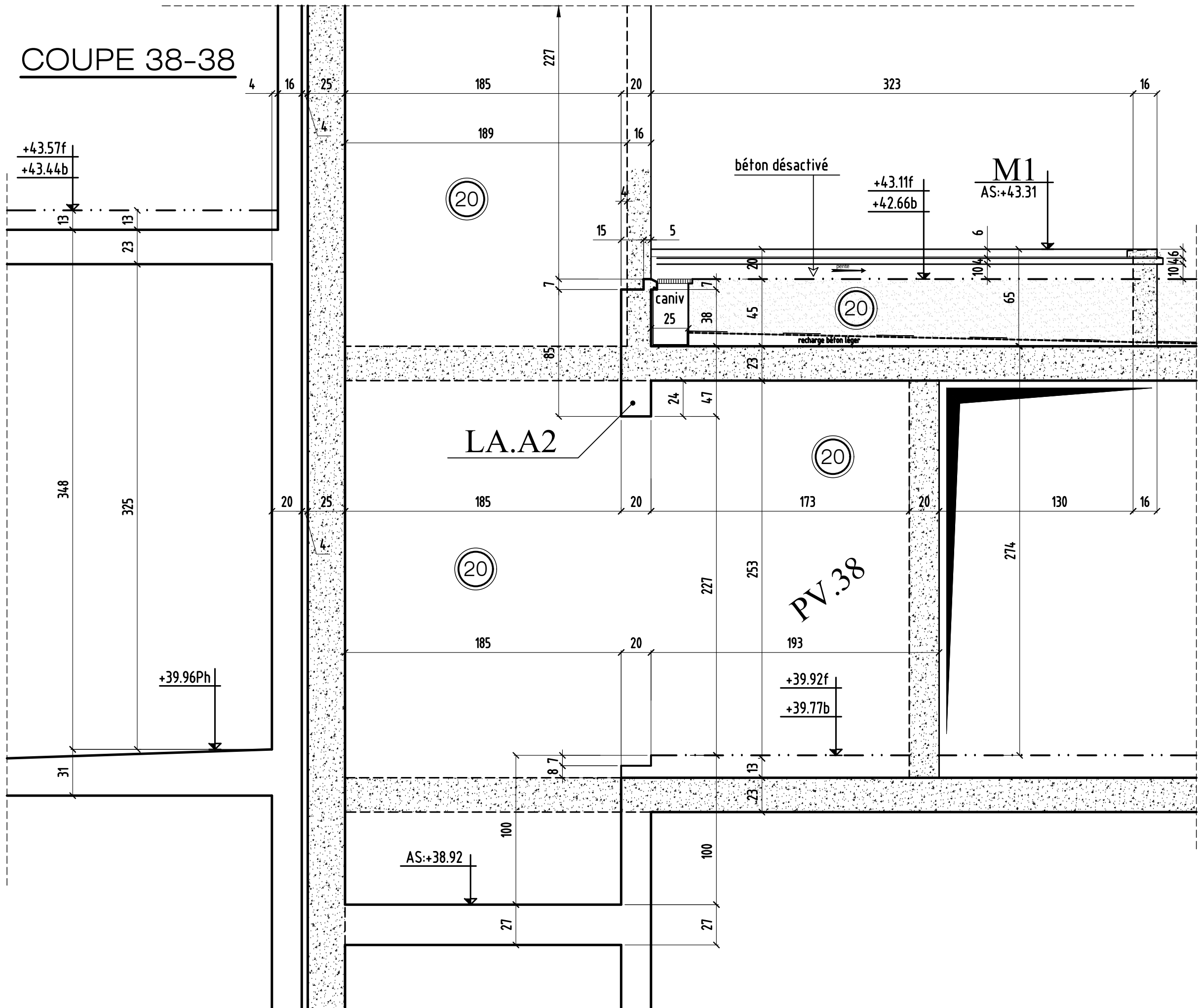

coupe 38-38

MODIFICATIONS		A	AFFAIRE:294	Cahier C.27
0		B	Ech:1/25	Page 14

# COUPE 39-39

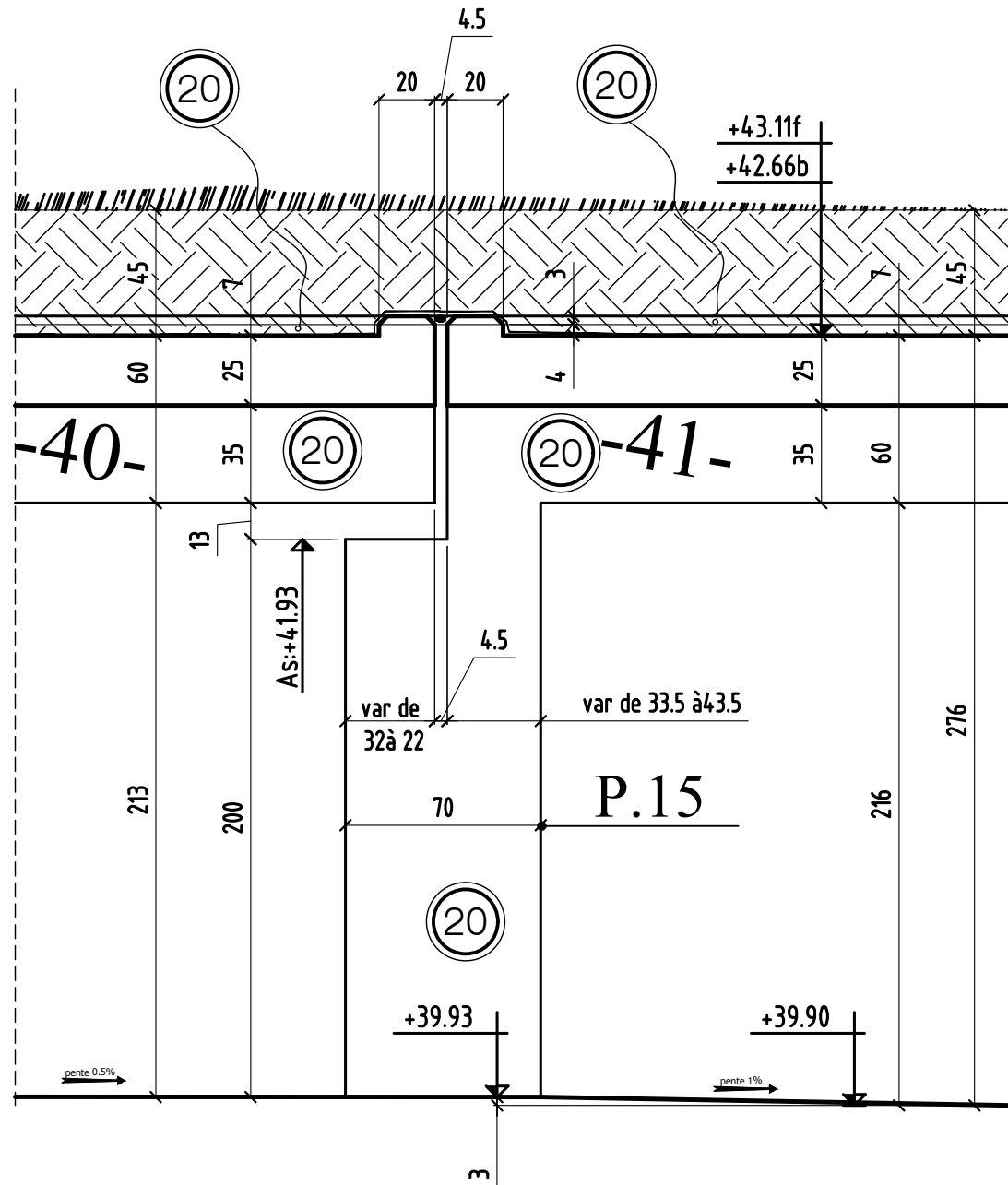

# COUPE 40-40

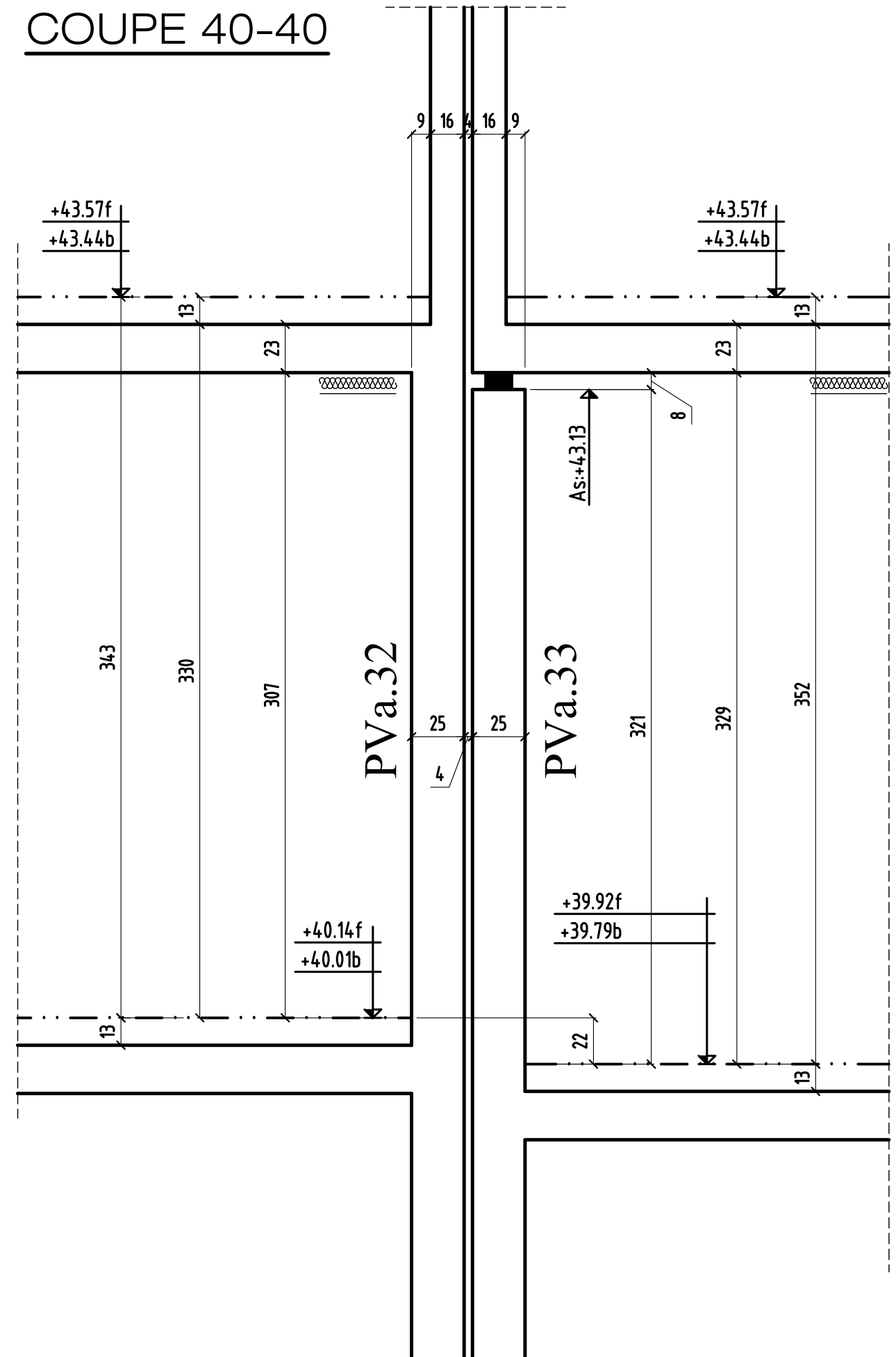

coupe 39-39 & 40-40

MODIFICATIONS

A

AFFAIRE:294

Cahier C.27

0

B

Ech:1/25

Page 15

# COUPE joint des poutres

## COUPE 41-41

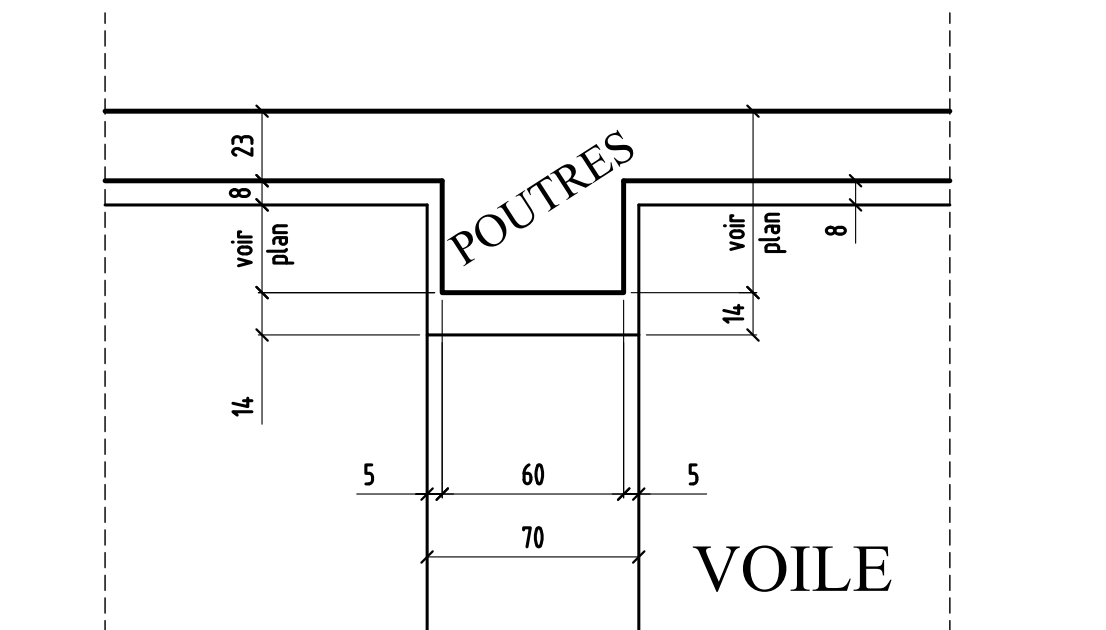

## COUPE 42-42

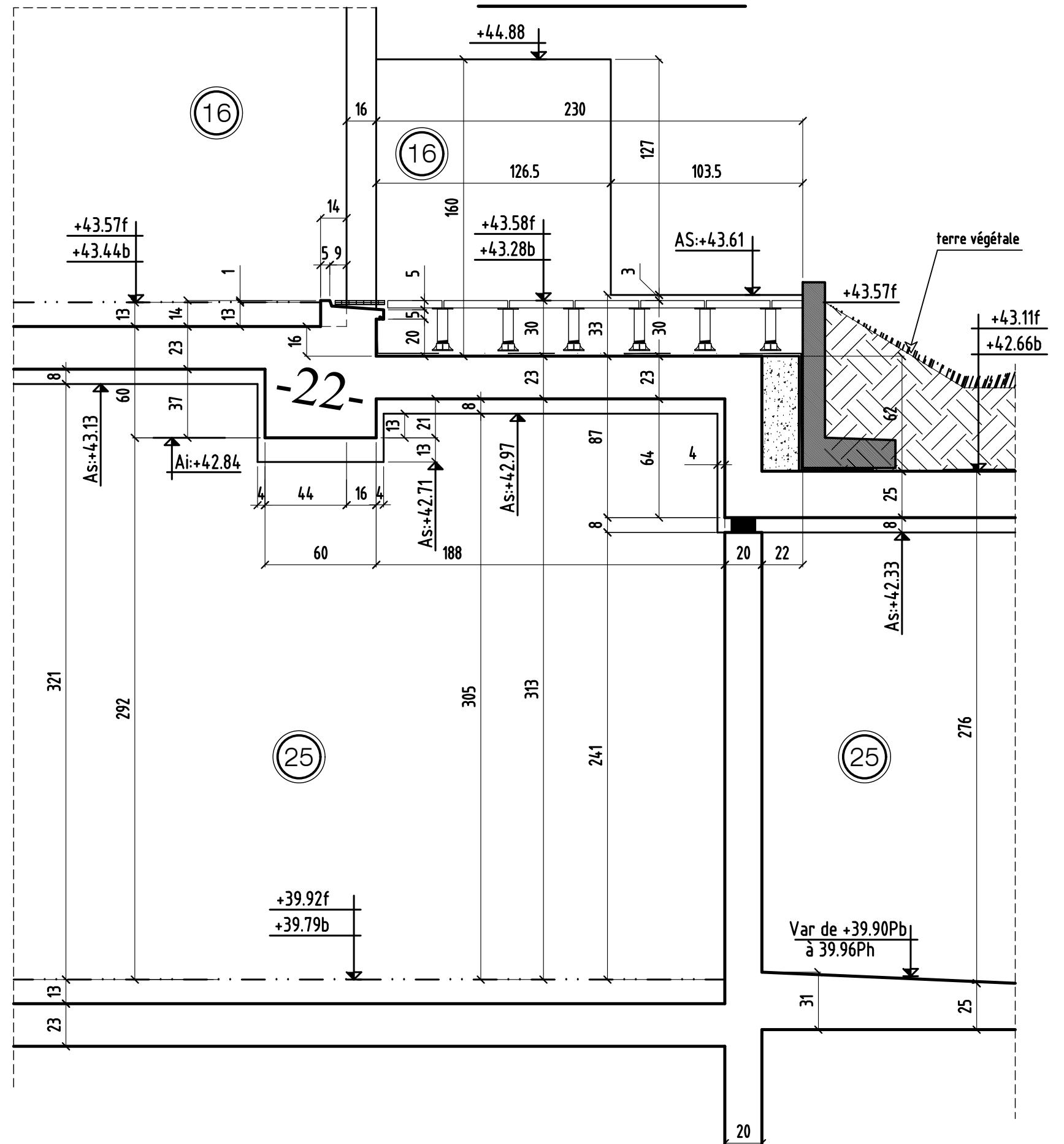



# COUPE 43-43

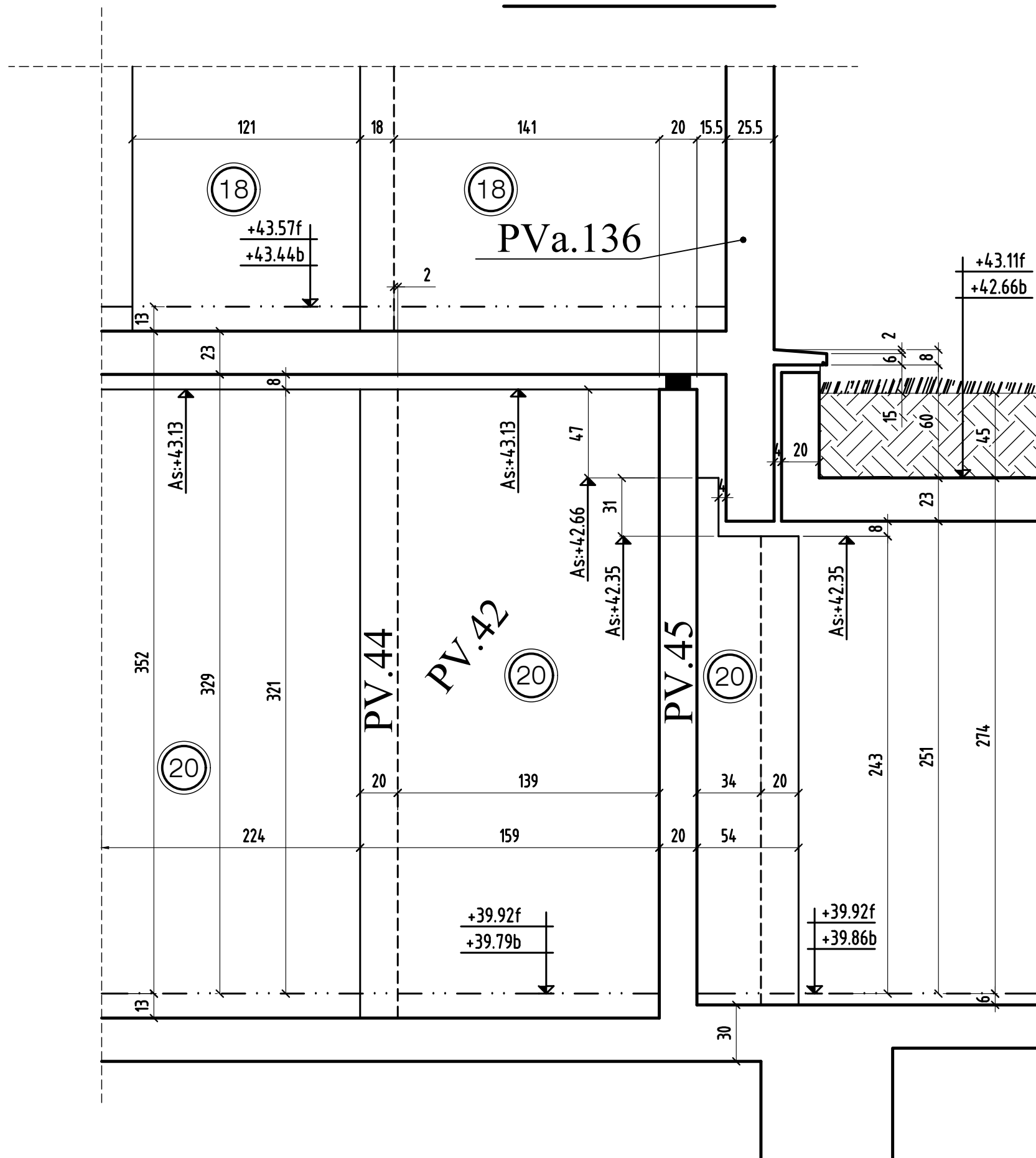

MODIFICATIONS

0	A
	B

AFFAIRE:294

Ech:1/25

Cahier C.27

Page 17

# COUPE 44-44

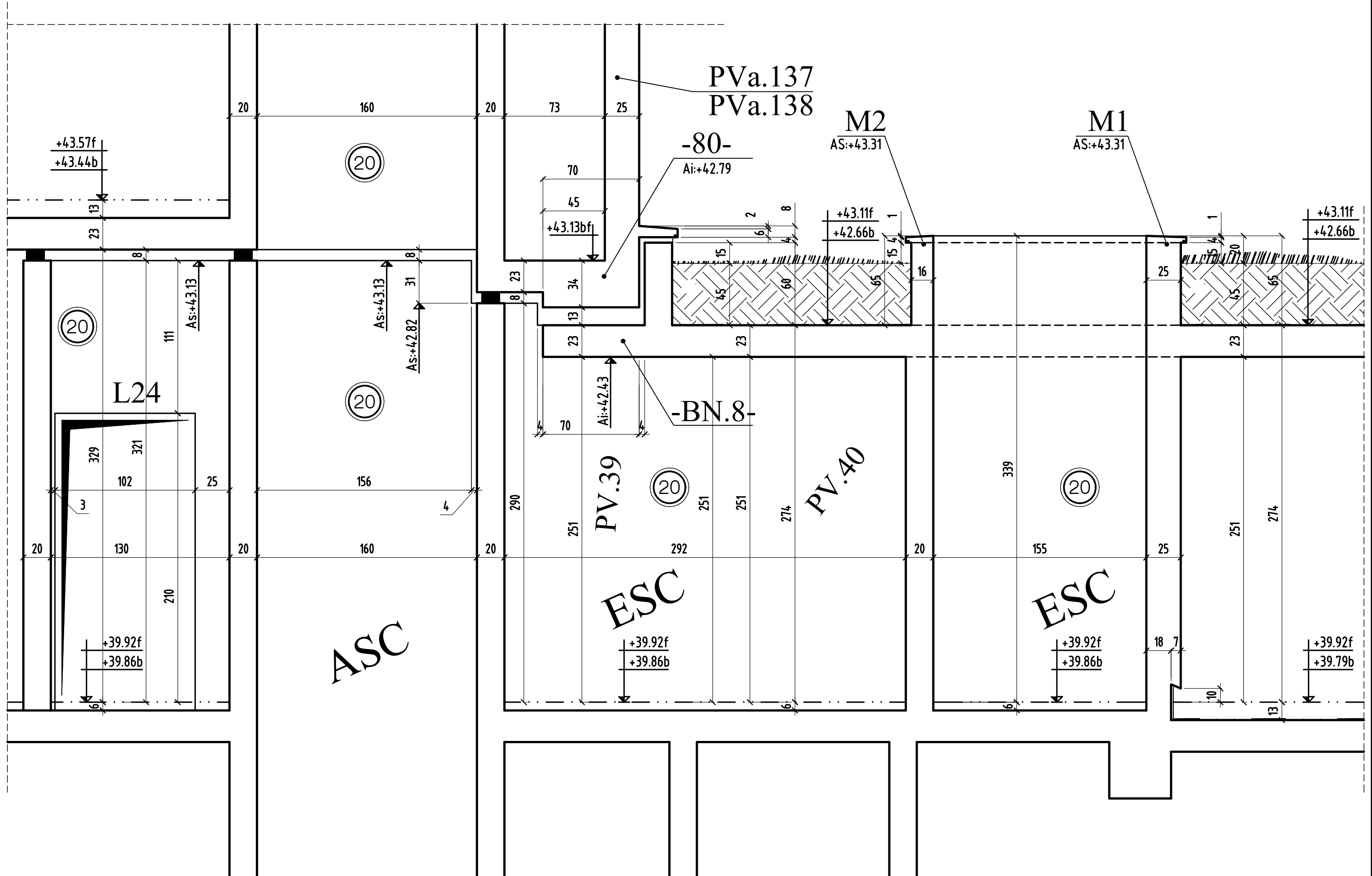

coupe 44-44

0	MODIFICATIONS	A	AFFAIRE:294	Cahier C.27
		B	Ech:1/25	Page 18

# COUPE 45-45

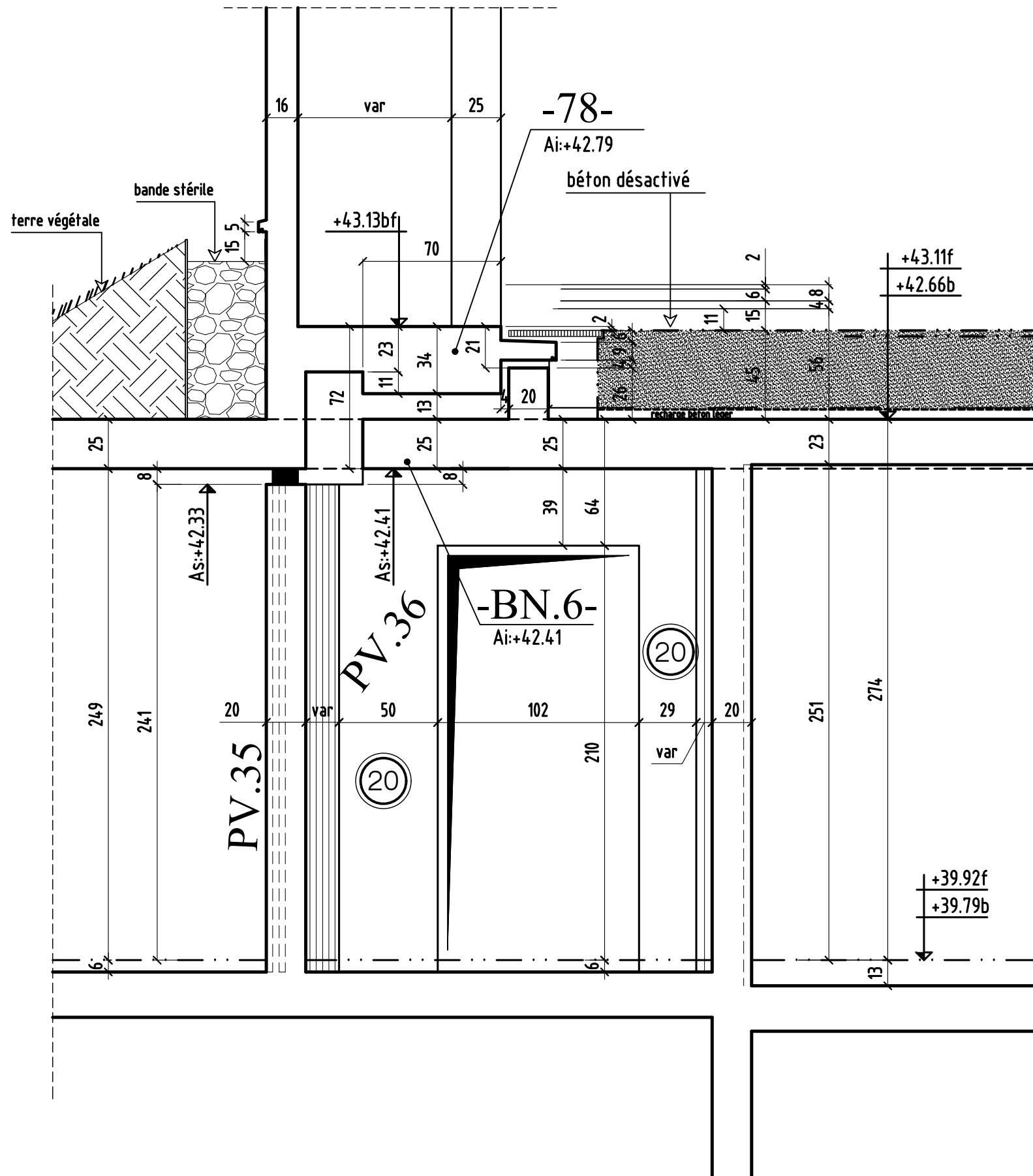

# COUPE 46-46

a confirmer

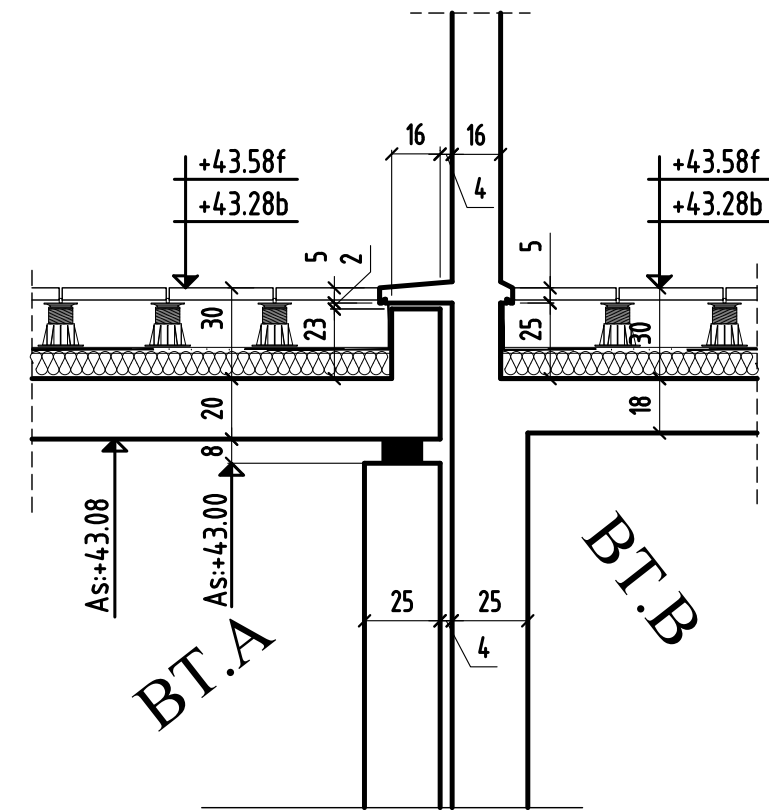



# COUPE 47-47

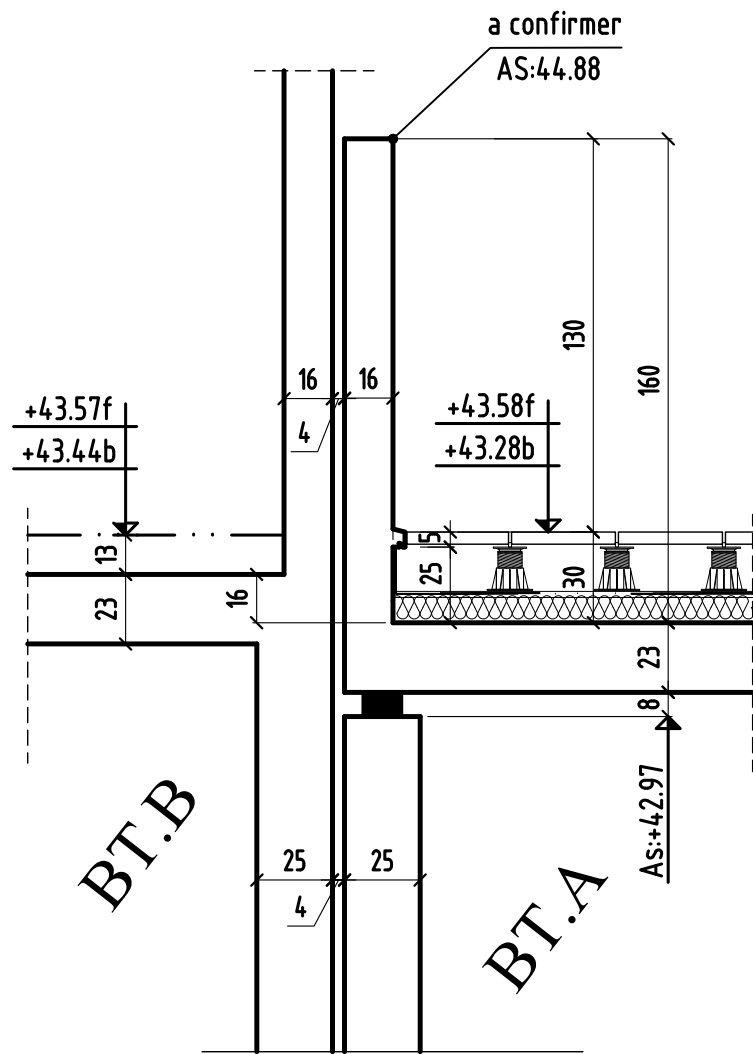

# COUPE 48-48

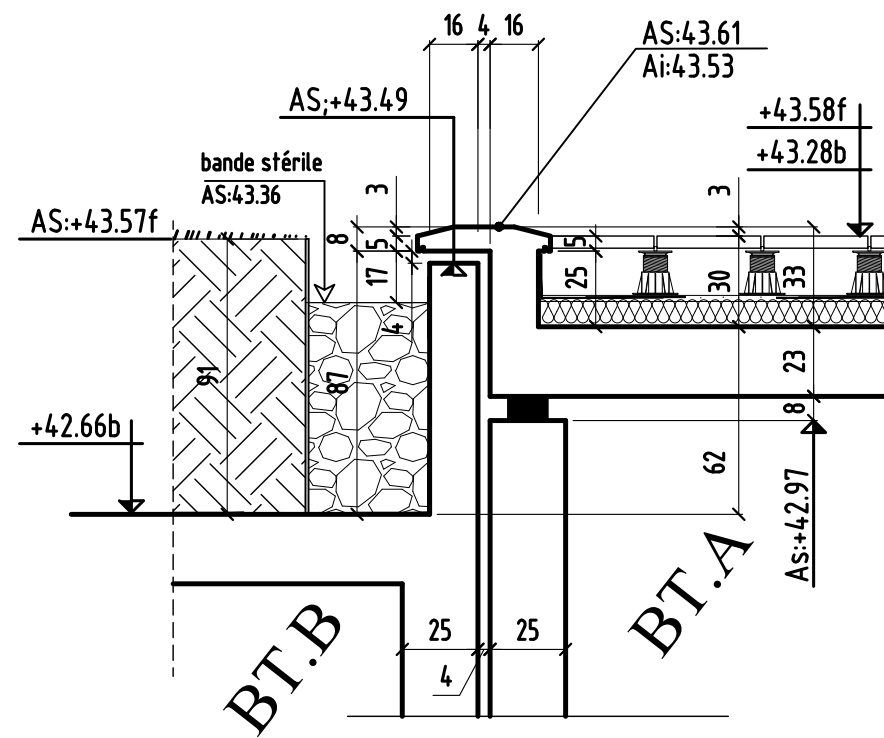

# COUPE 49-49

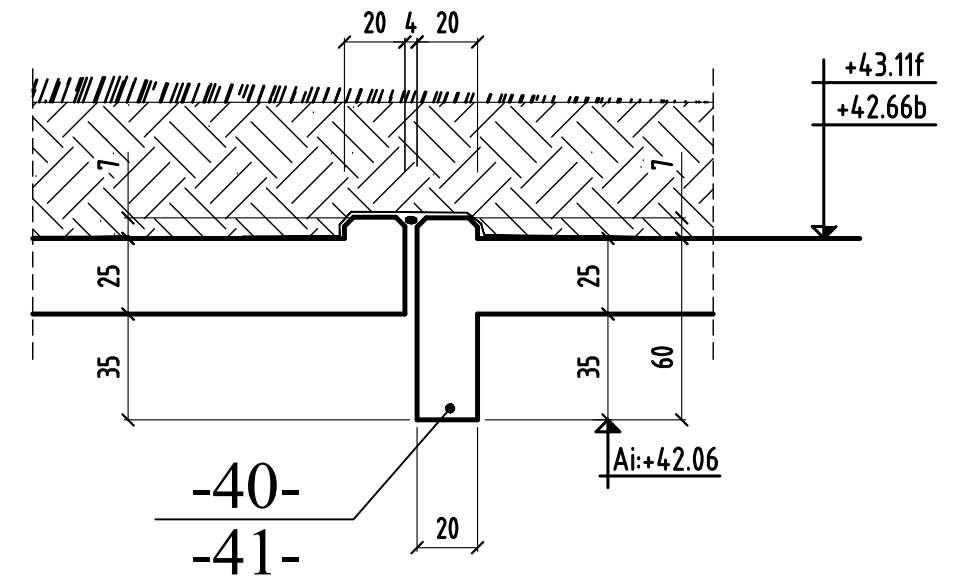

### COUPE 50-50

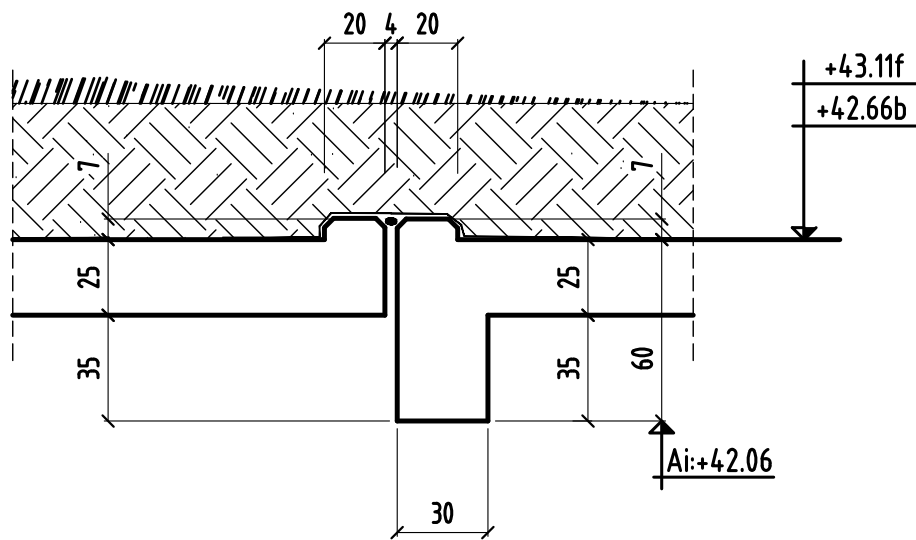

### COUPE 51-51

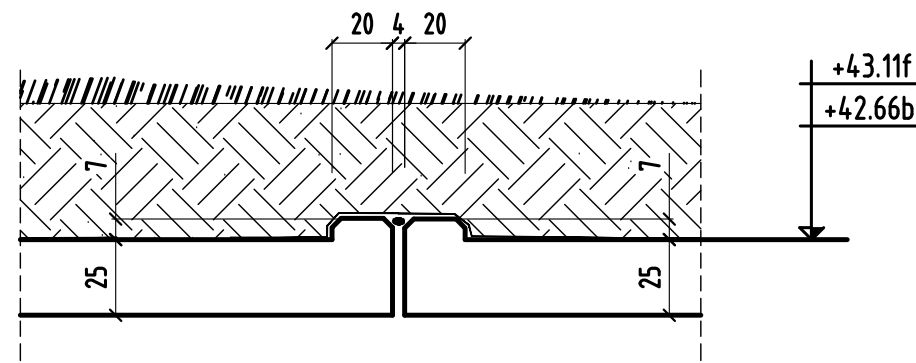

### COUPE 52-52

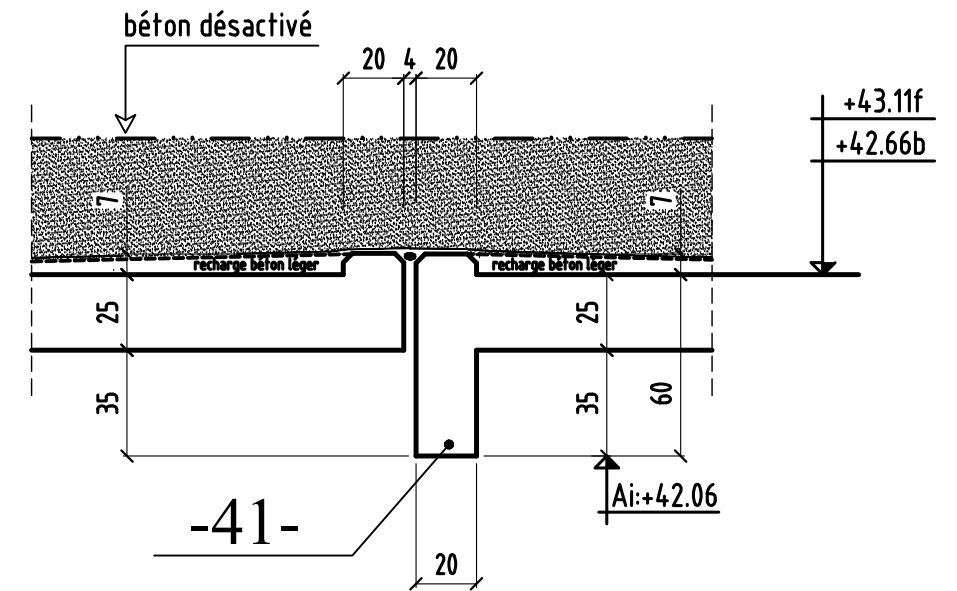

### COUPE 54-54

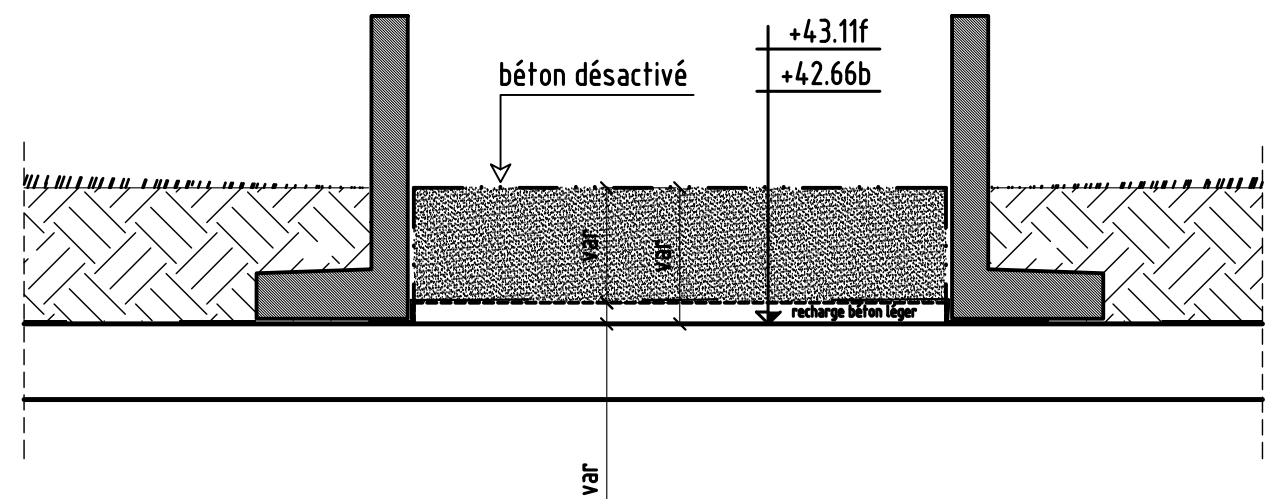

### COUPE 53-53

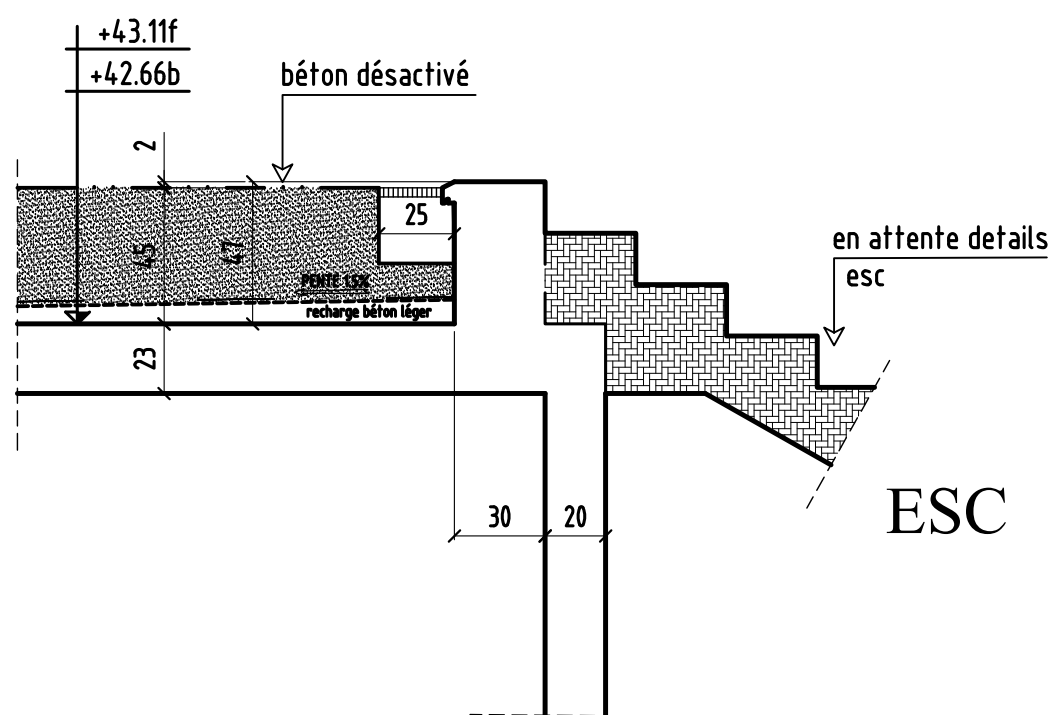

# COUPE joint des voiles & PV

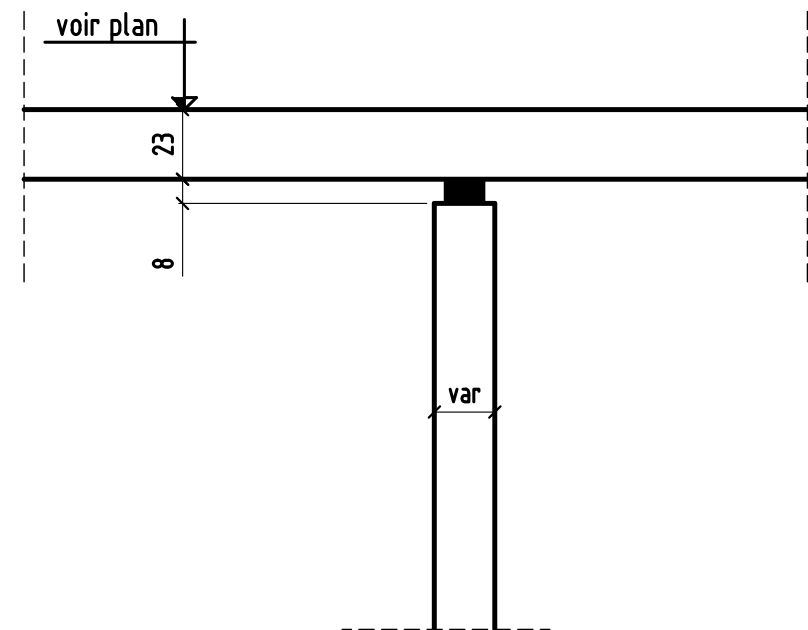

# COUPE X-X

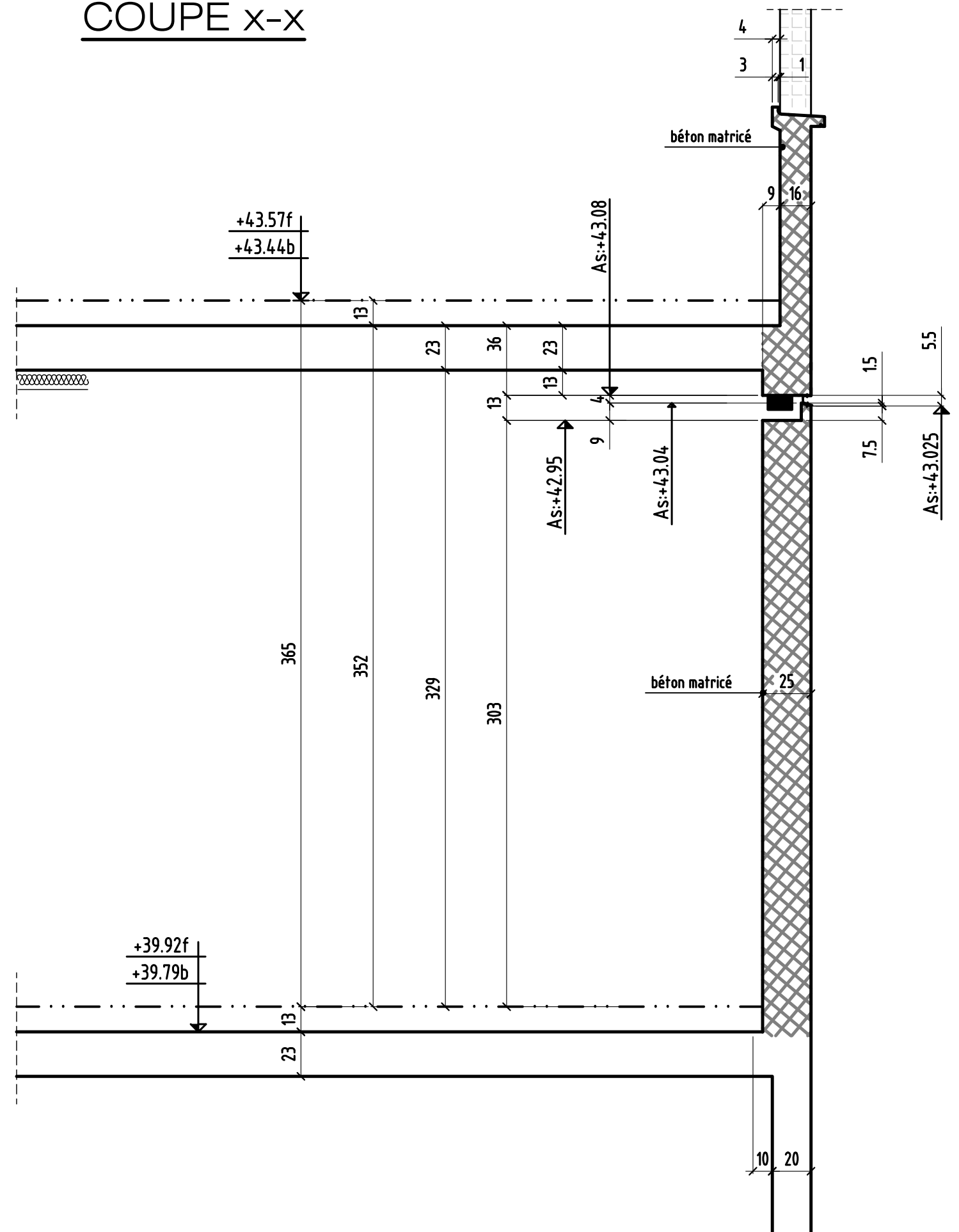

0	MODIFICATIONS	A	AFFAIRE:294	Cahier C.27
		B	Ech:1/25	Page 22

# COUPE Y-Y

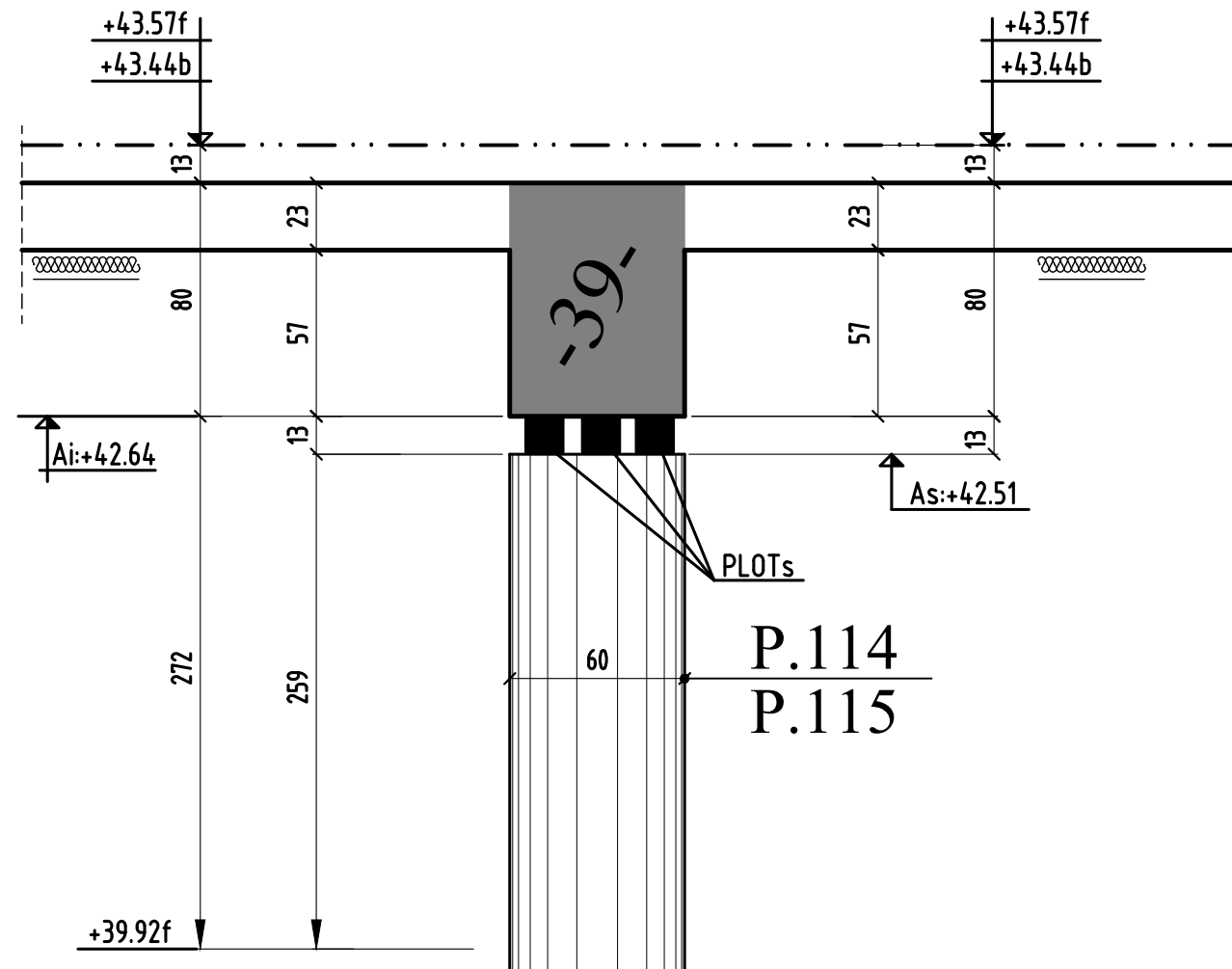

CHOISY LE ROI

94600

**CONSTRUCTION D'UN ENSEMBLE  
DE 107 LOGEMENTS SOCIAUX & commerces  
bts: A & B & F**

94600 CHOISY LE ROI  
ILOT 1

<b>MAITRE D' OEUVRE</b>	<b>MAITRE D'OUVRAGE</b>
<b>CITE ARCHITECTURE</b> 11 RUE FLATTERS 75005 PARIS ☎: 01.48.28.44.10 ☎: 01.48.28.44.18	<b>BOUYGUES IMMOBILIER</b> 27, avenue des Murs du Parc 94300 Vincennes ☎: 01.58.64.53.54 ☎: 01.58.64.53.03
<b>BUREAU DE CONTROLE</b>	<b>ENTREPRISE G.O.</b>
<b>QUALICONSULT</b> 127/121 chemin des Bassins 93035 CRETEIL ☎: 01.49.56.06.00 ☎: 01.48.71.85.81	<b>M.T.R</b> 9, rue René Cassin 77173 CHEVRY-COSSIGNY ☎: 01.60.62.32.00 ☎: 01.60.62.32.01

**COFFRAGE - COUPES & DETAILS**  
*Pht RDC*  
*bt: B*

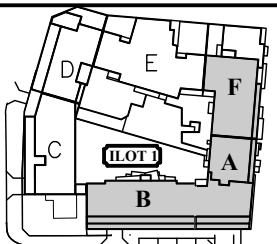

ind.	date	modifications
0	06-12-17	1 ère diffusion.
A	20-12-17	MISE A JOUR SUIVANT MODIF PLAN COFFRAGE
B	27-03-18	MISE A JOUR SUIVANT VISA MOE
C	23-04-18	MISE A JOUR SUIVANT VISA MOE

	DOSSIER		PLAN		APD
	294		C.08		IND.
					EXE
	Ingenieur		Projeteur	Date	Echelle
		H.B.E	06/12/17	1/25	



# COUPE 1-1

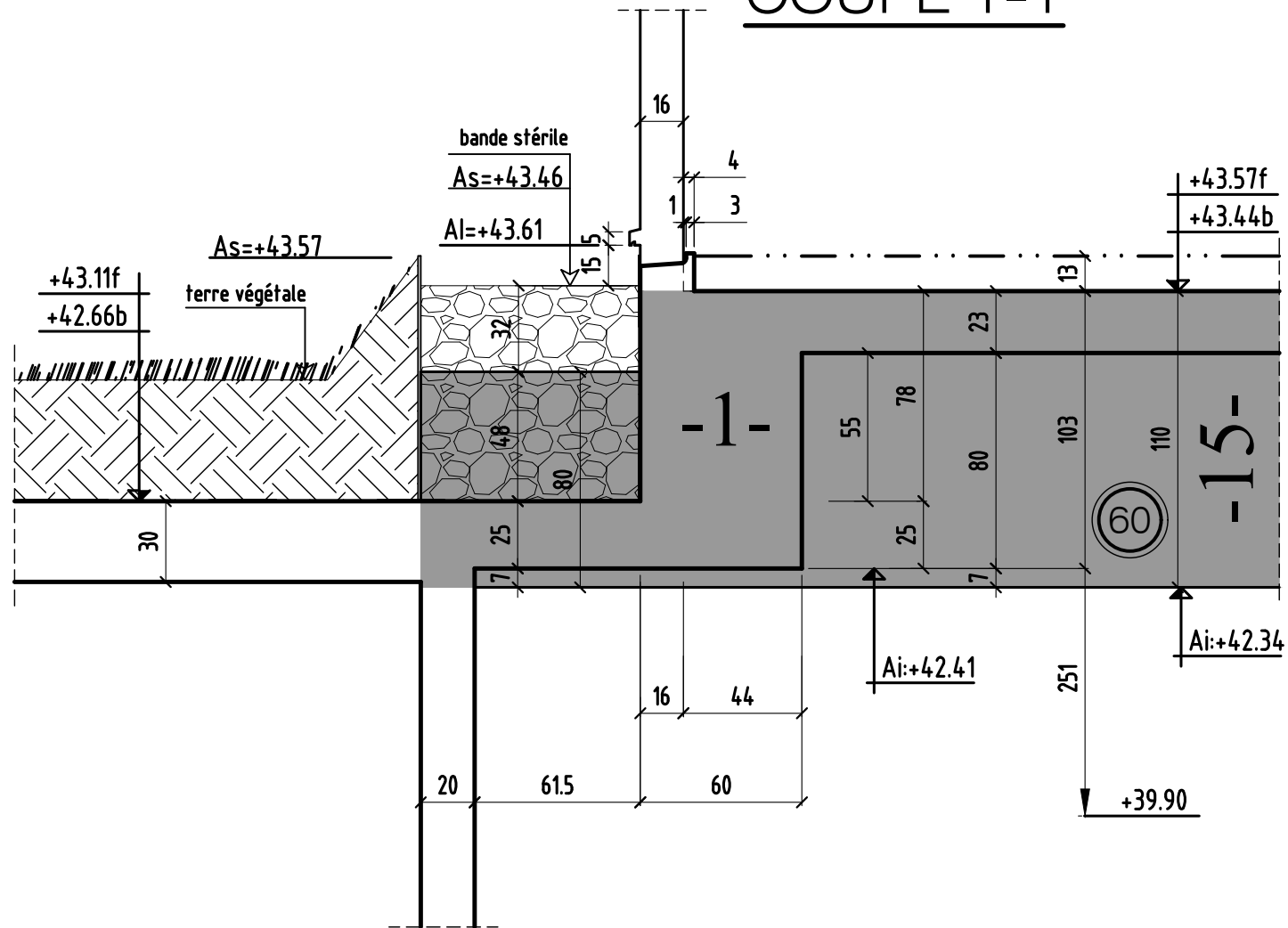

# COUPE 2-2

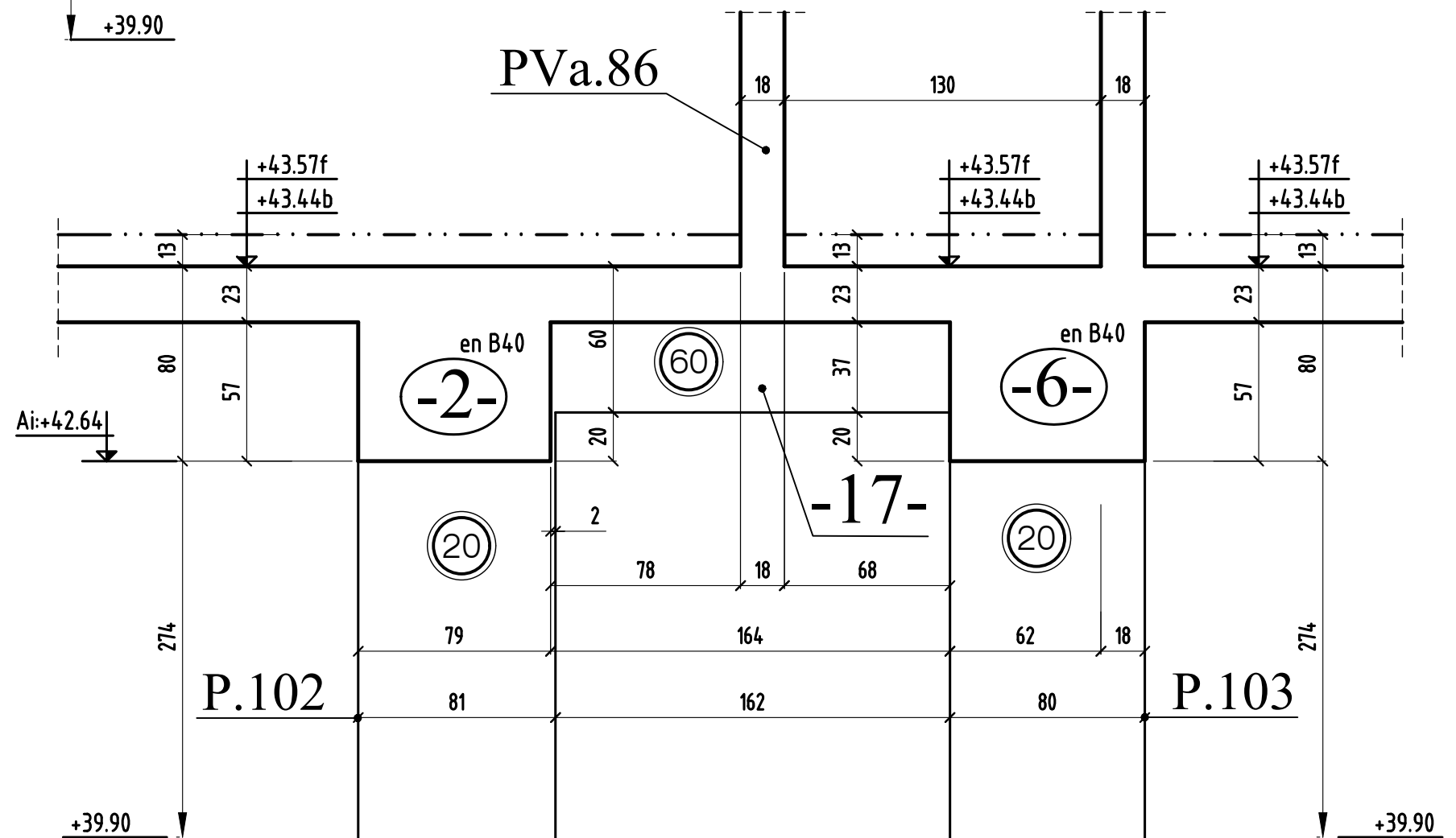

coupe 1-1 & 2-2

0	MODIFICATIONS	A	AFFAIRE:294	Cahier C.08
		B	Ech:1/25	Page 01

# COUPE 3-3

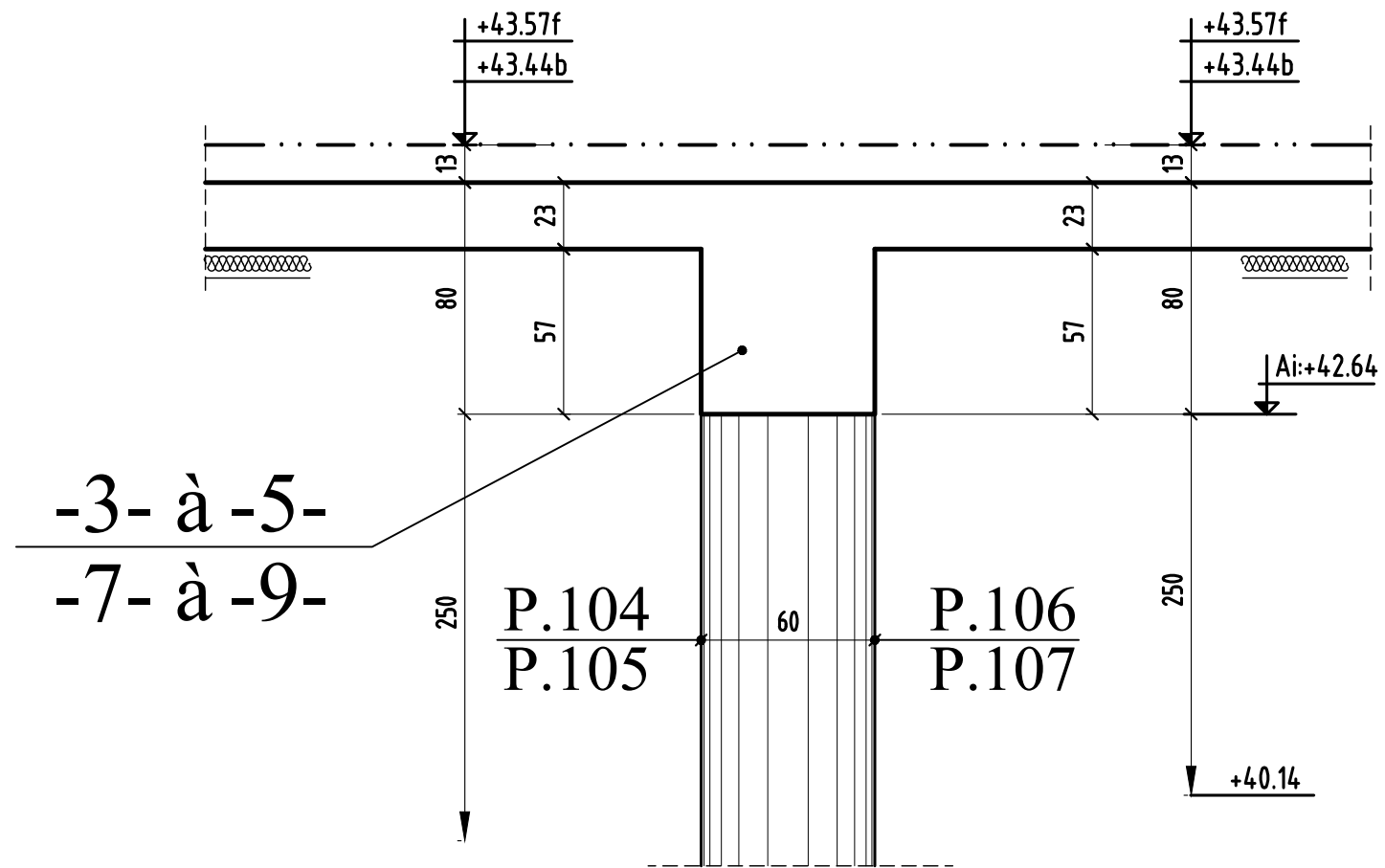

# COUPE 4-4

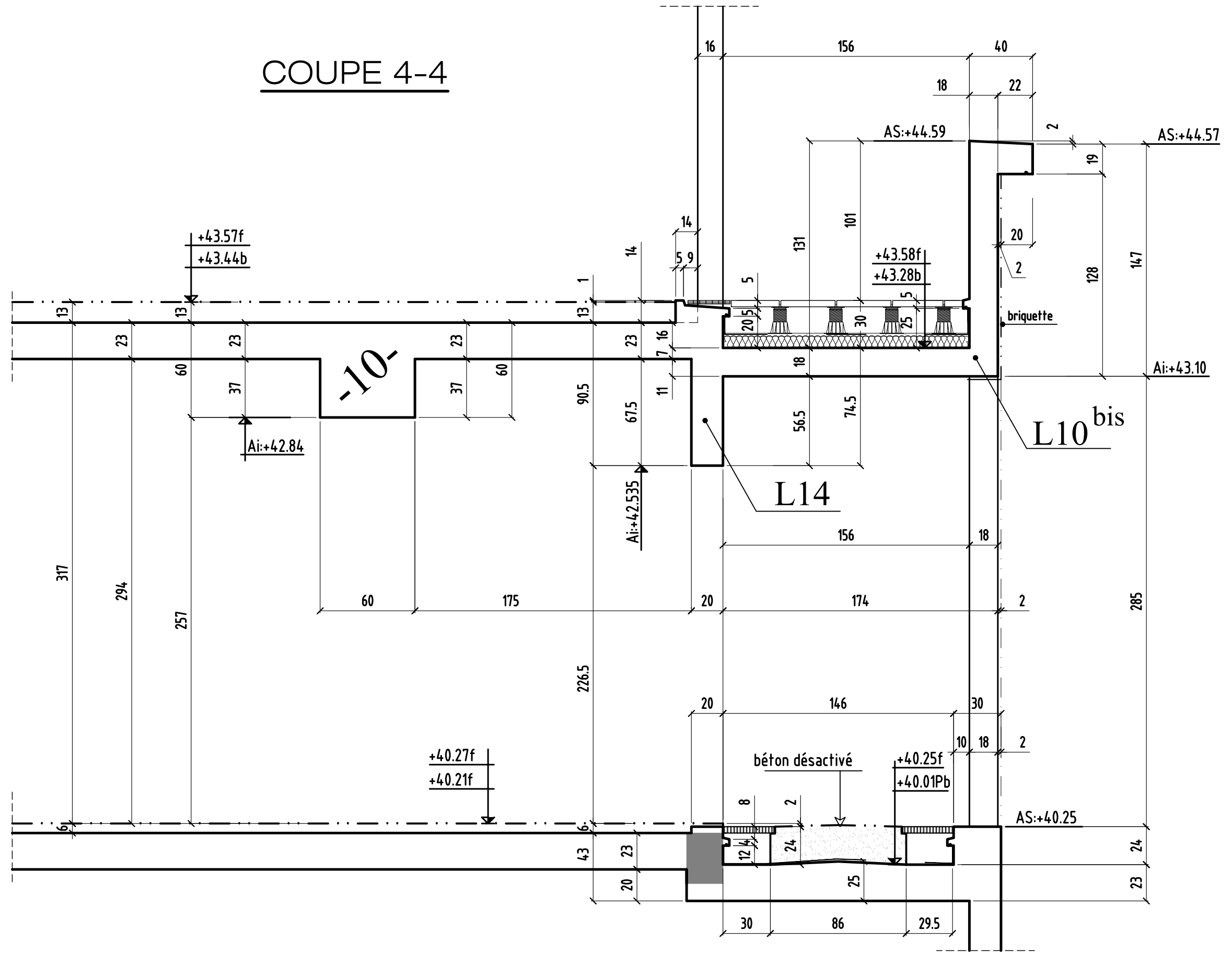

0	MODIFICATIONS	A	AFFAIRE:294	Cahier C.08
		B	Ech:1/25	Page 03

COUPE 5-5

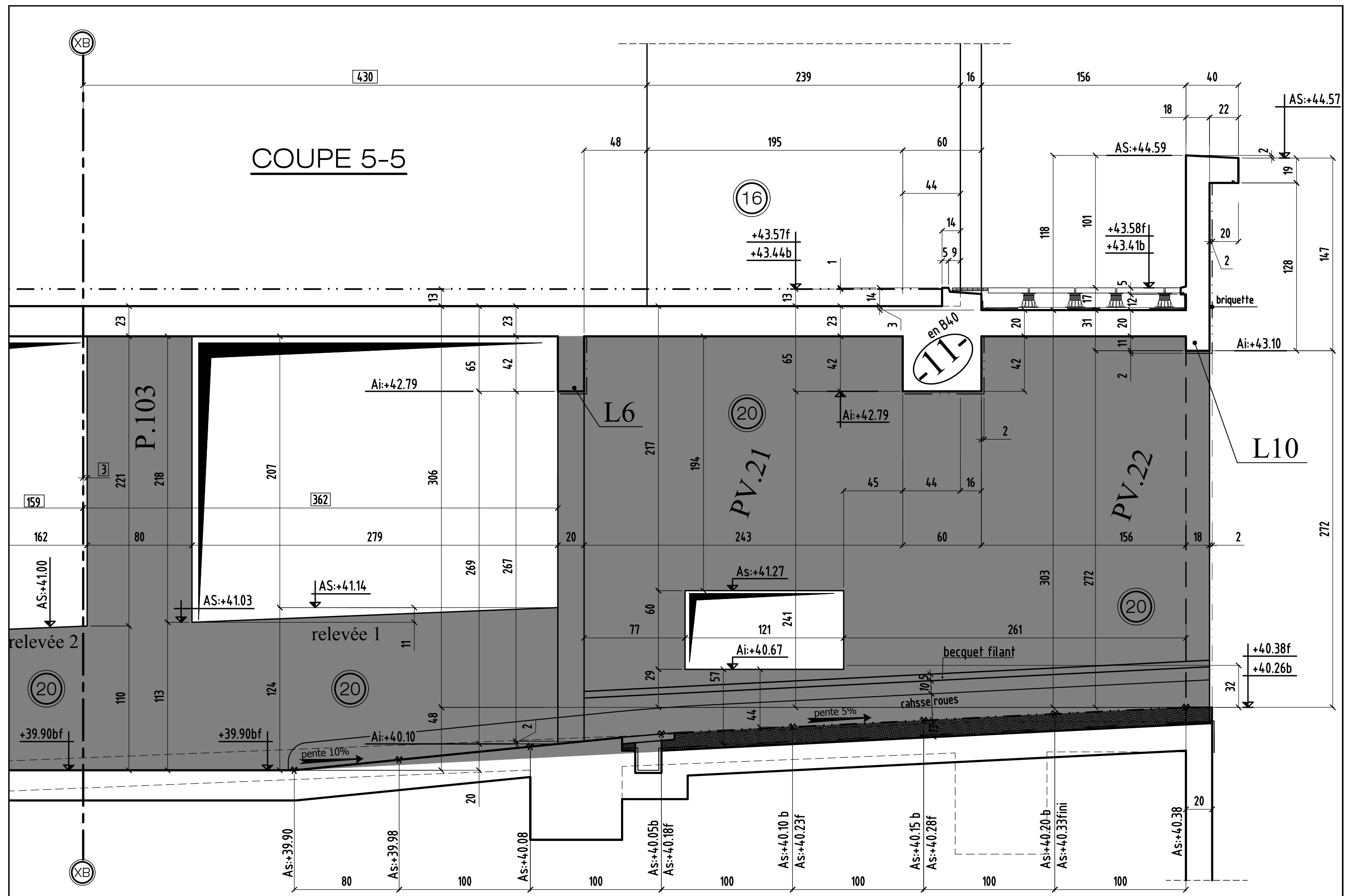

coupe 5-5

0	MODIFICATIONS	A	AFFAIRE:294	Cahier C.08
		B	Ech:1/25	Page 04

# COUPE 6-6

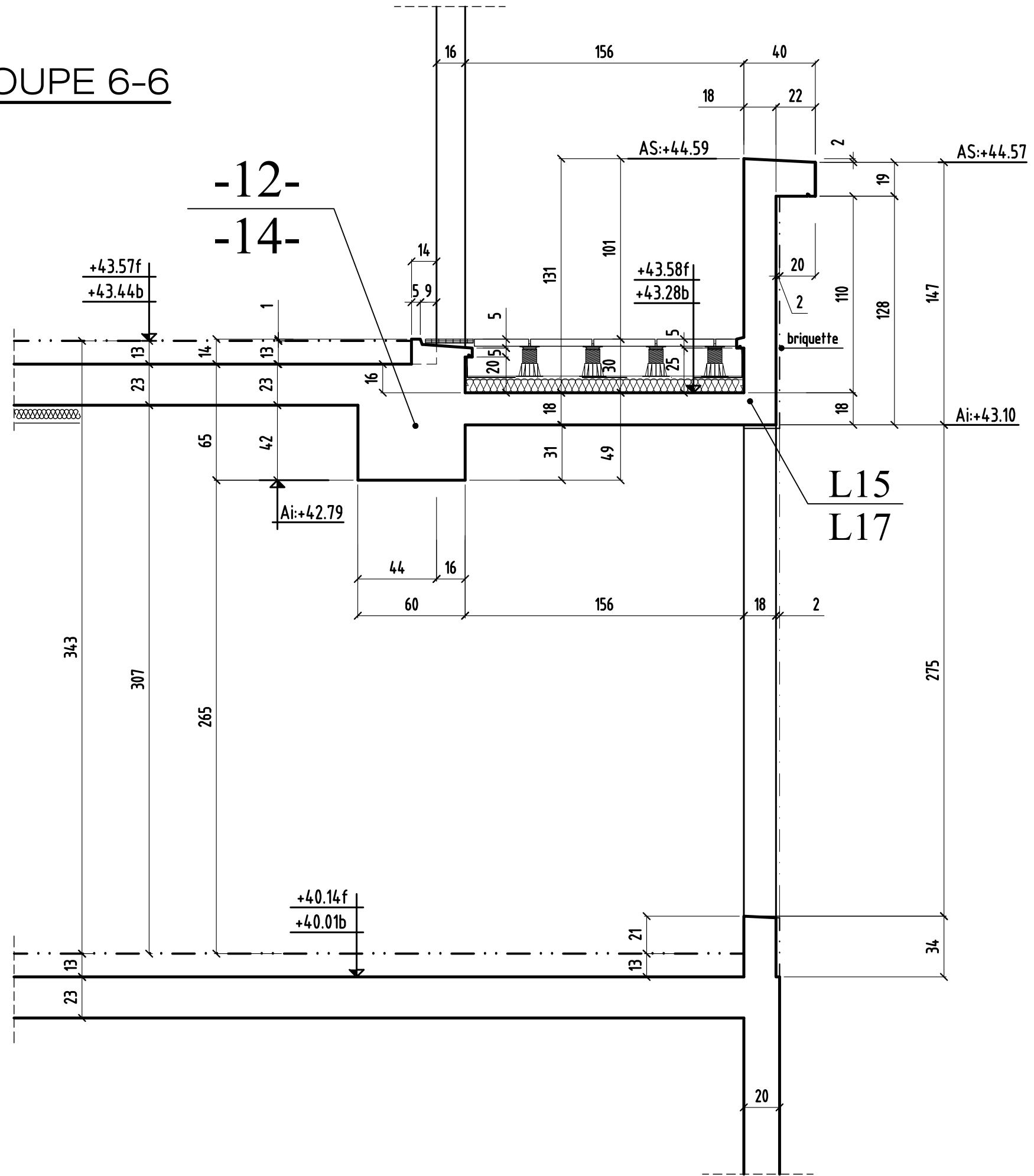



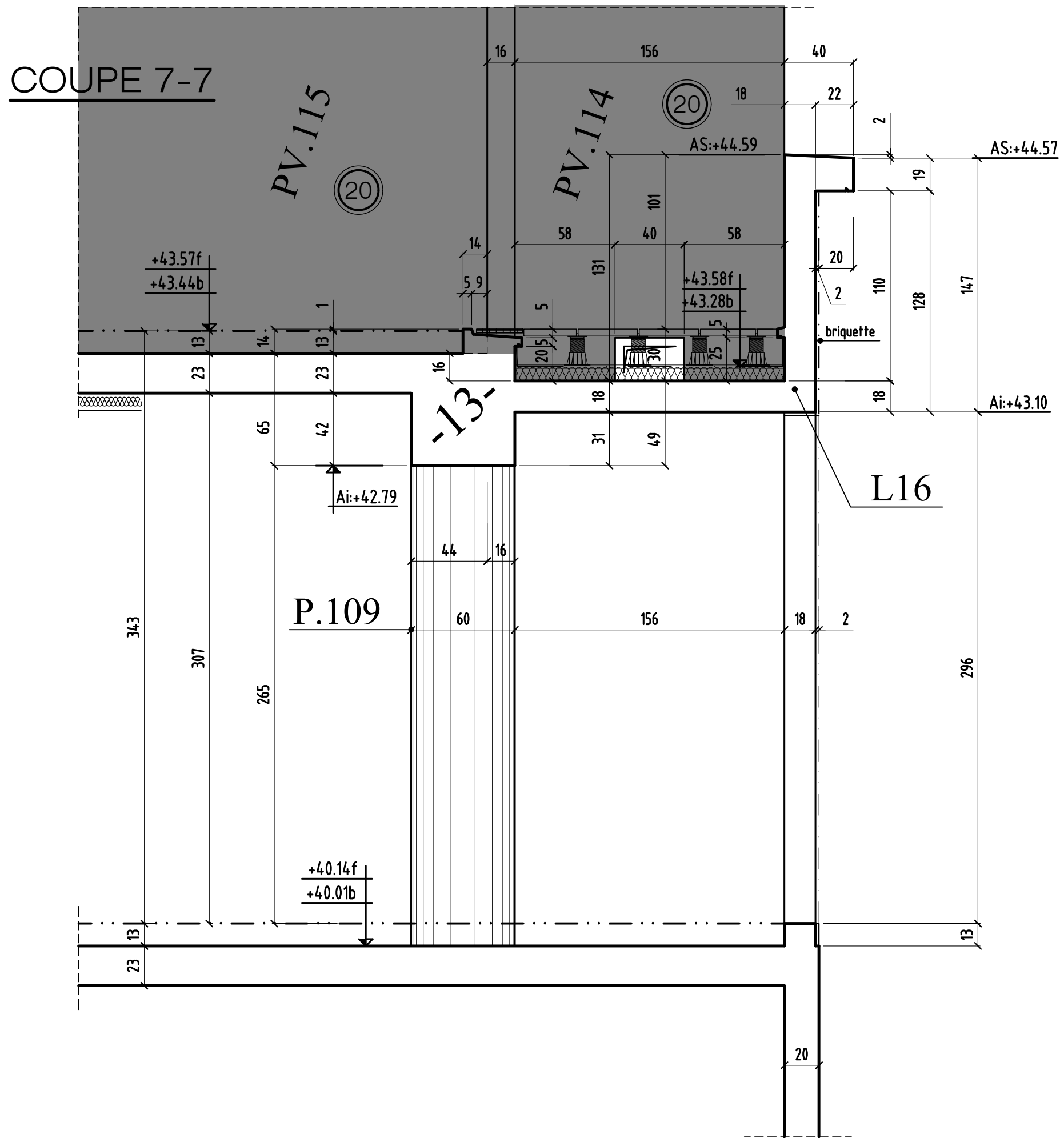

coupe 7-7

0	MODIFICATIONS	A	AFFAIRE:294	Cahier C.08
		B	Ech:1/25	Page 06

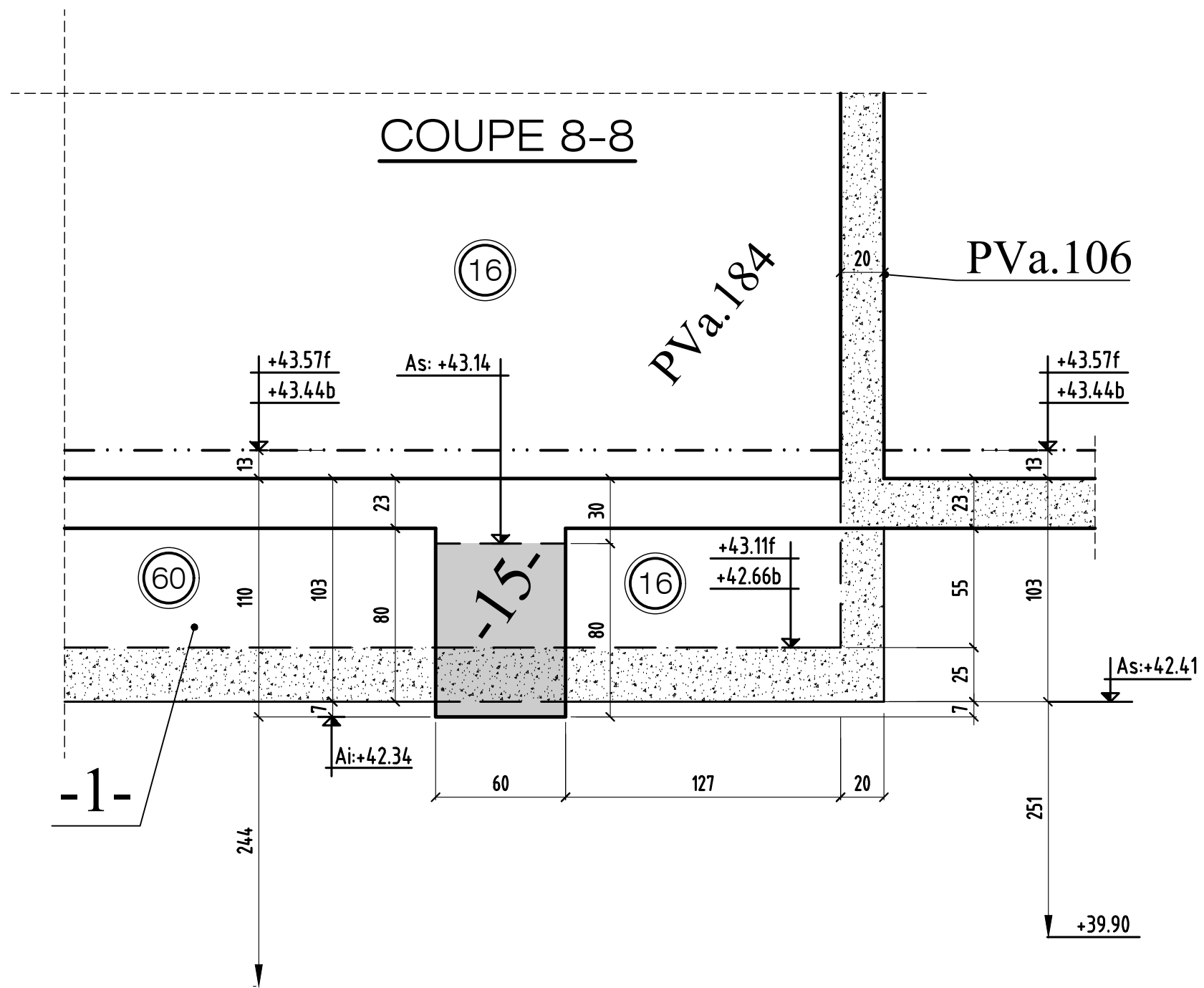

# COUPE 9-9

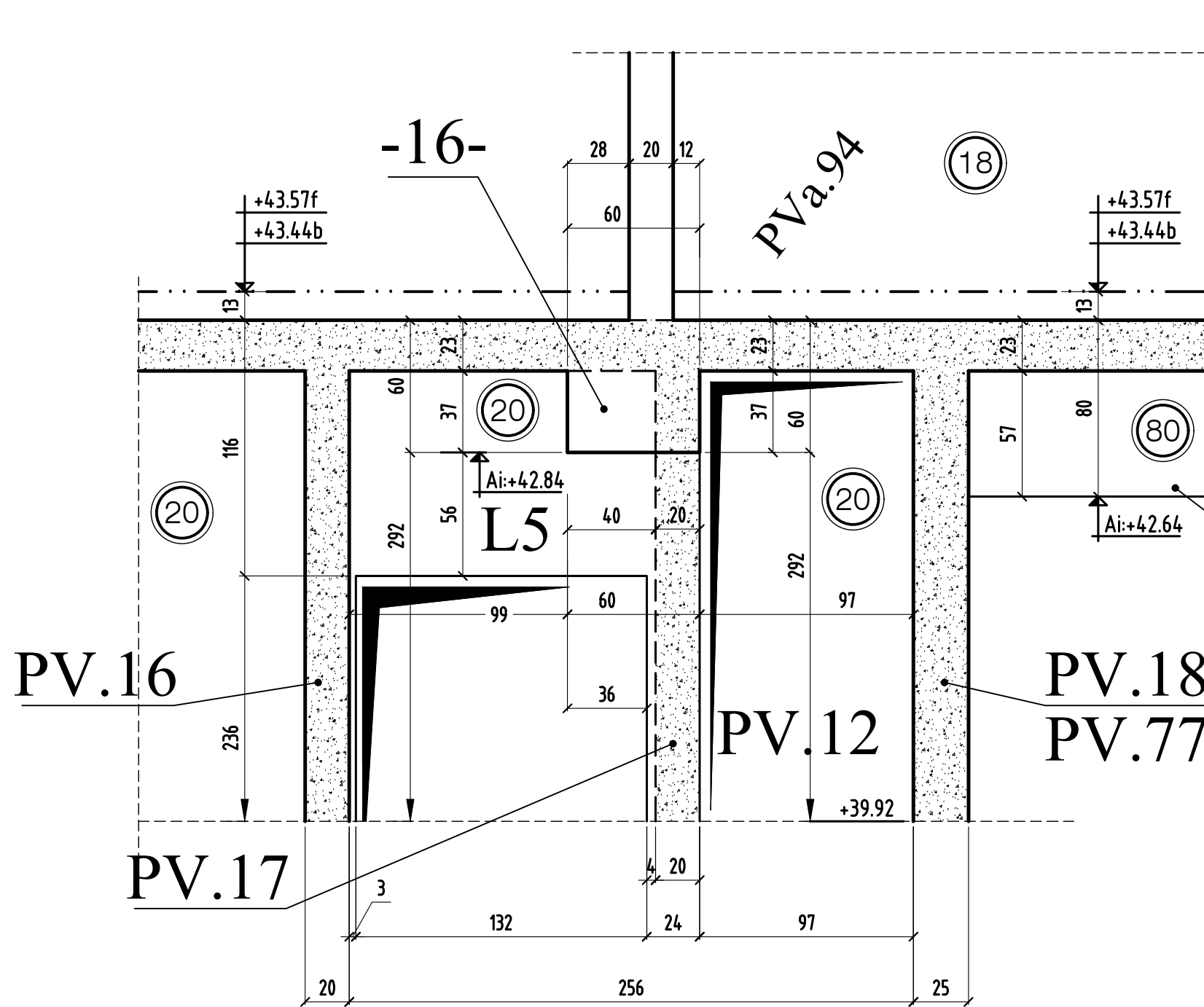

# COUPE 10-10

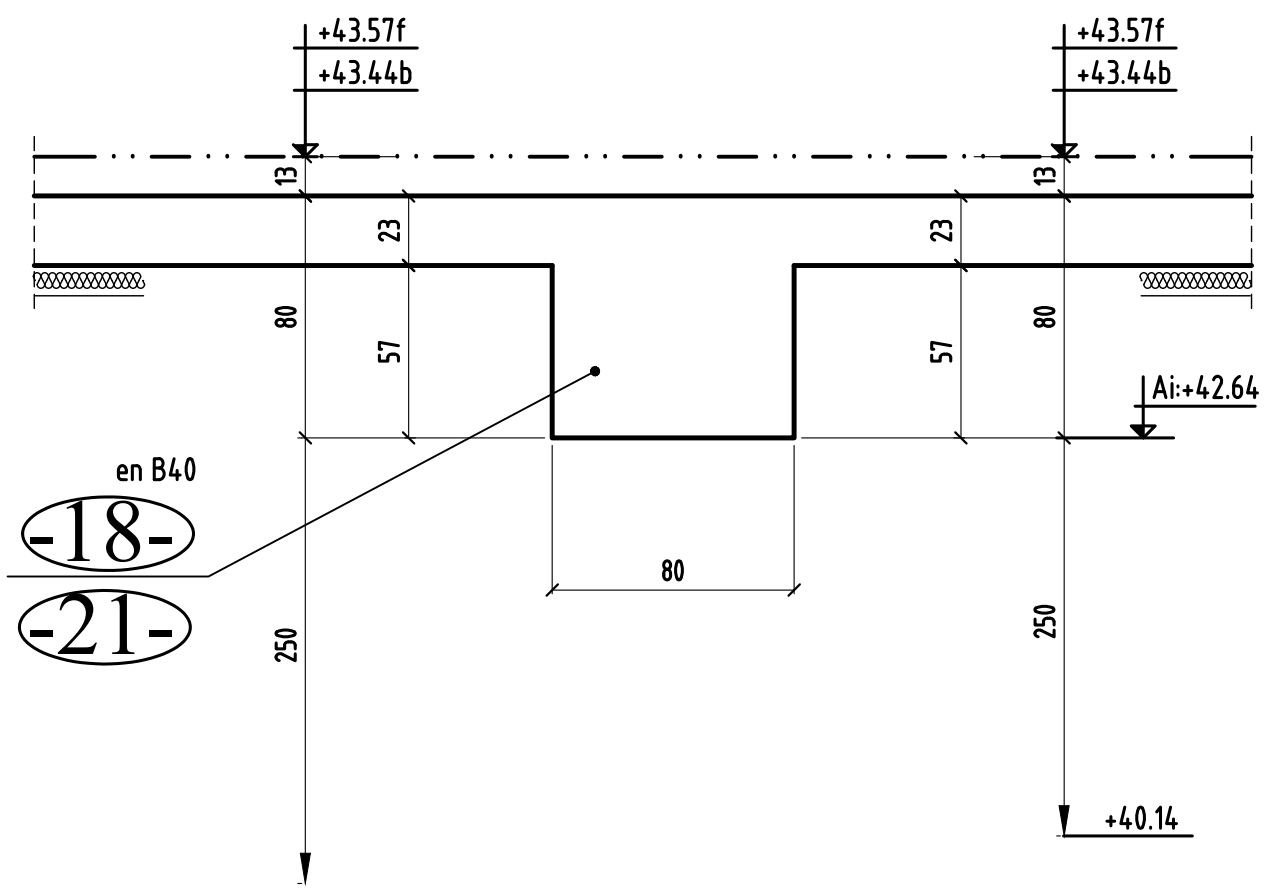

coupe 9-9 & 10-10

0	MODIFICATIONS	A	AFFAIRE:294	Cahier C.08
		B	Ech:1/25	Page 08

# COUPE 11-11

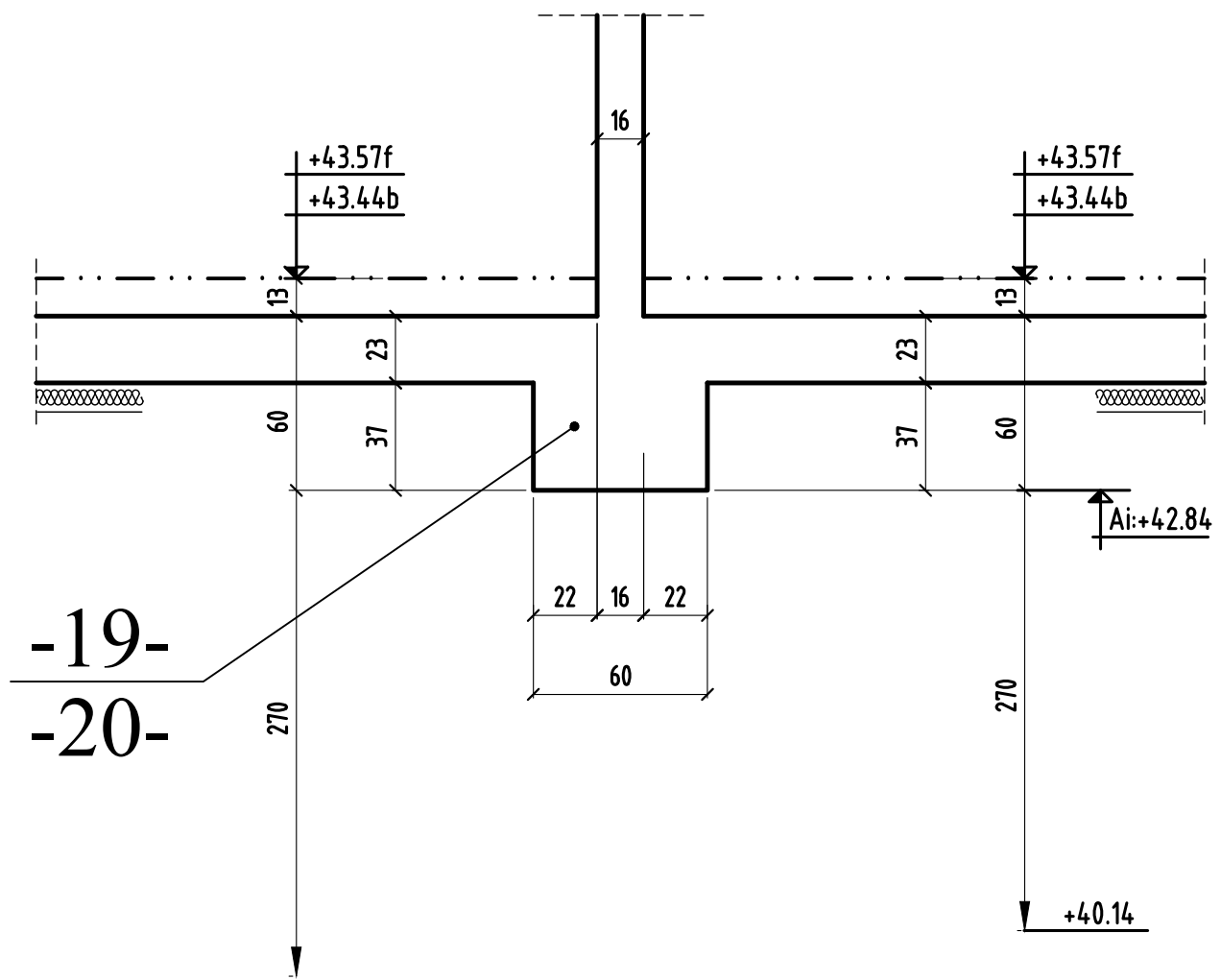

# COUPE 12-12

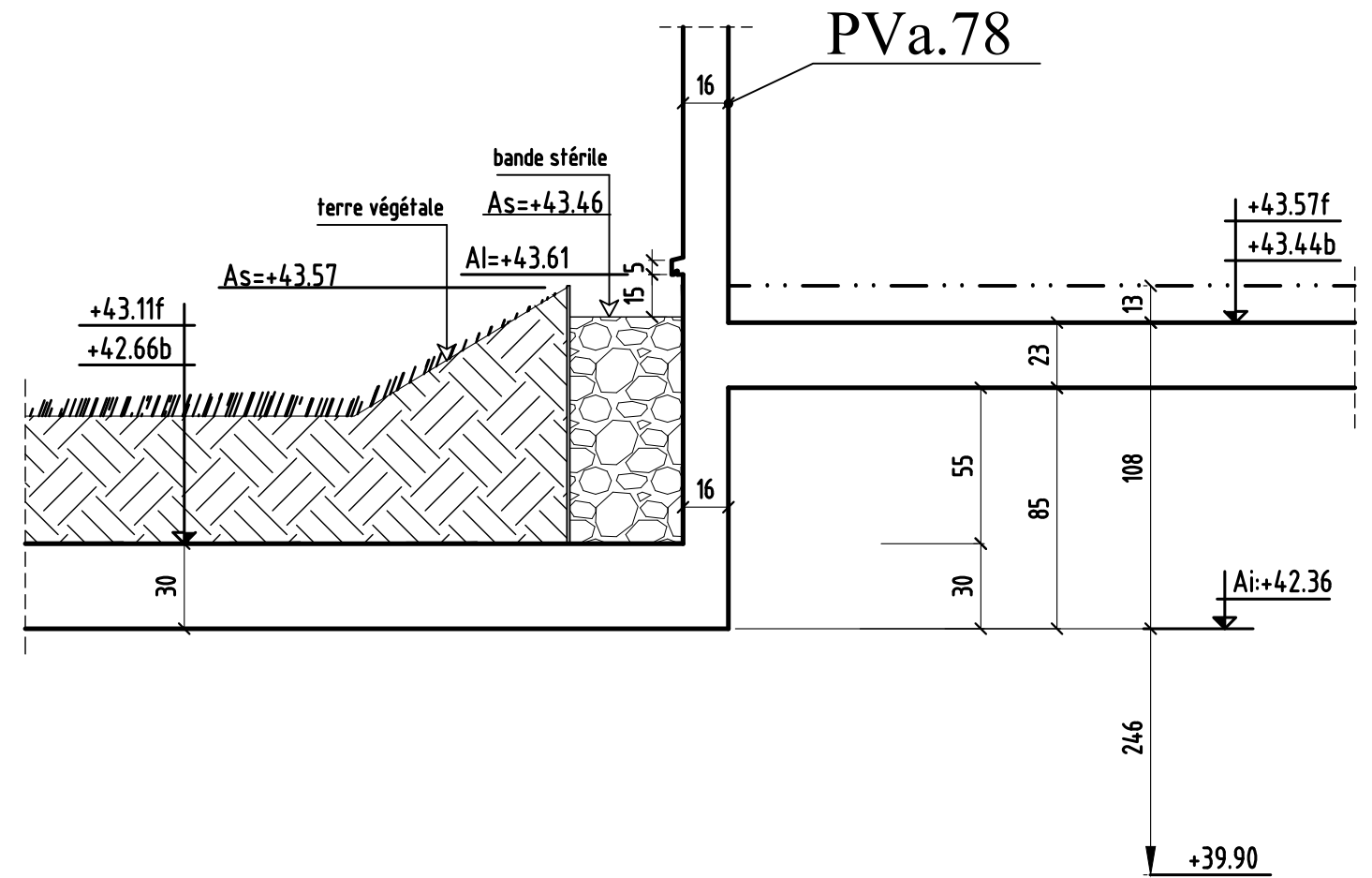

# COUPE 13-13

PVa.79&PVa.80  
PVa.82&PVa.83

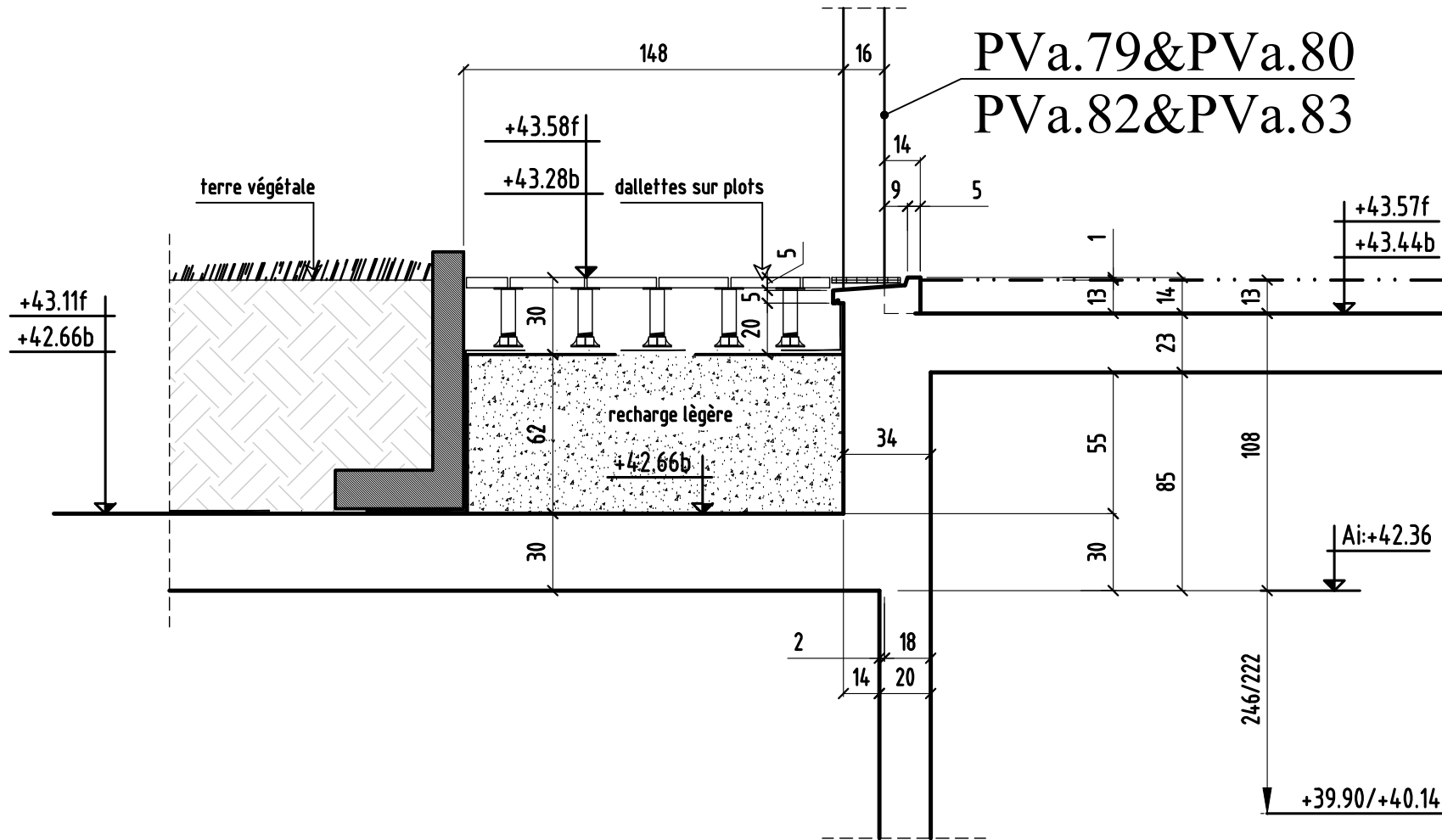

# COUPE 14-14

PVa.85

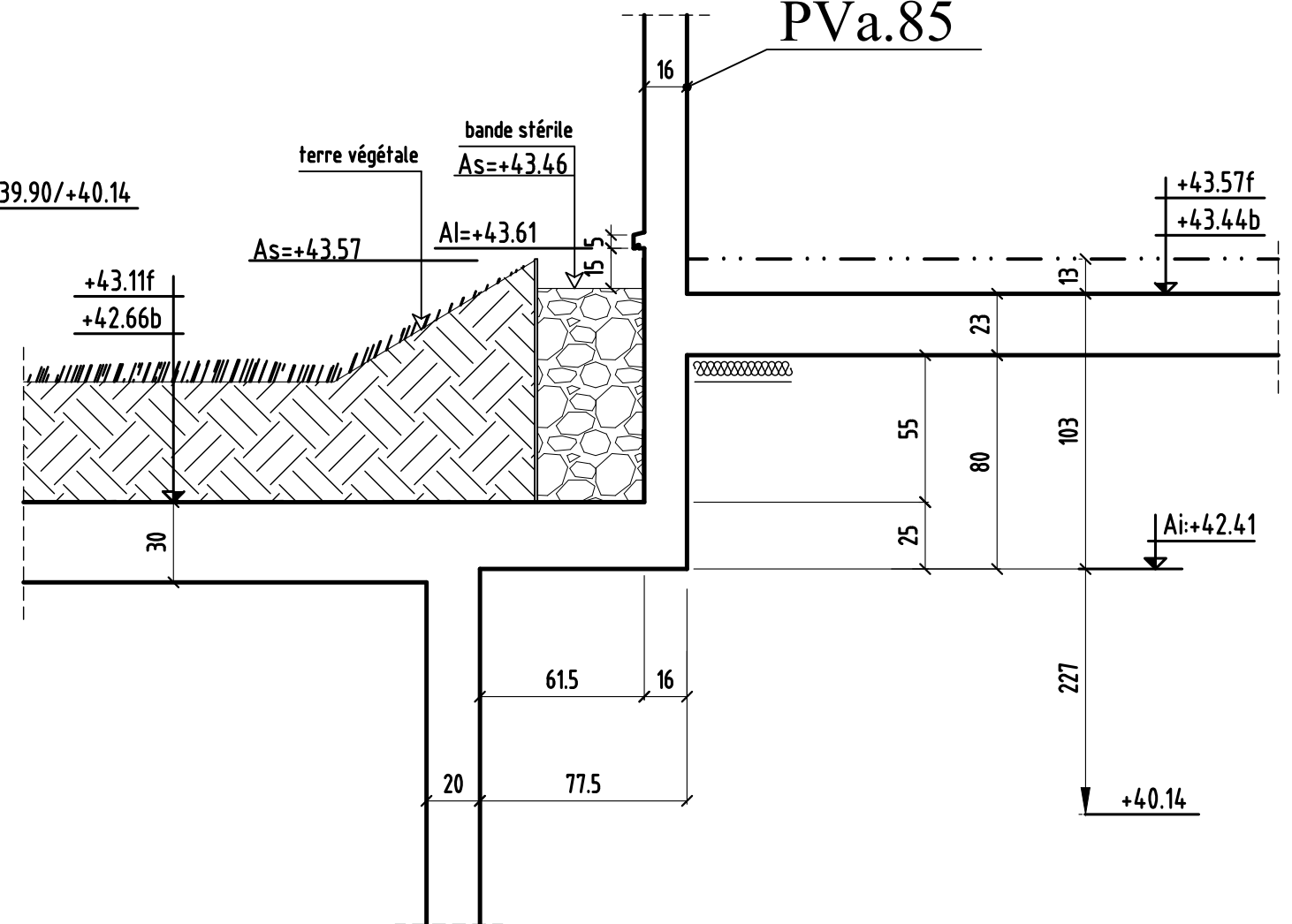



# COUPE 15-15

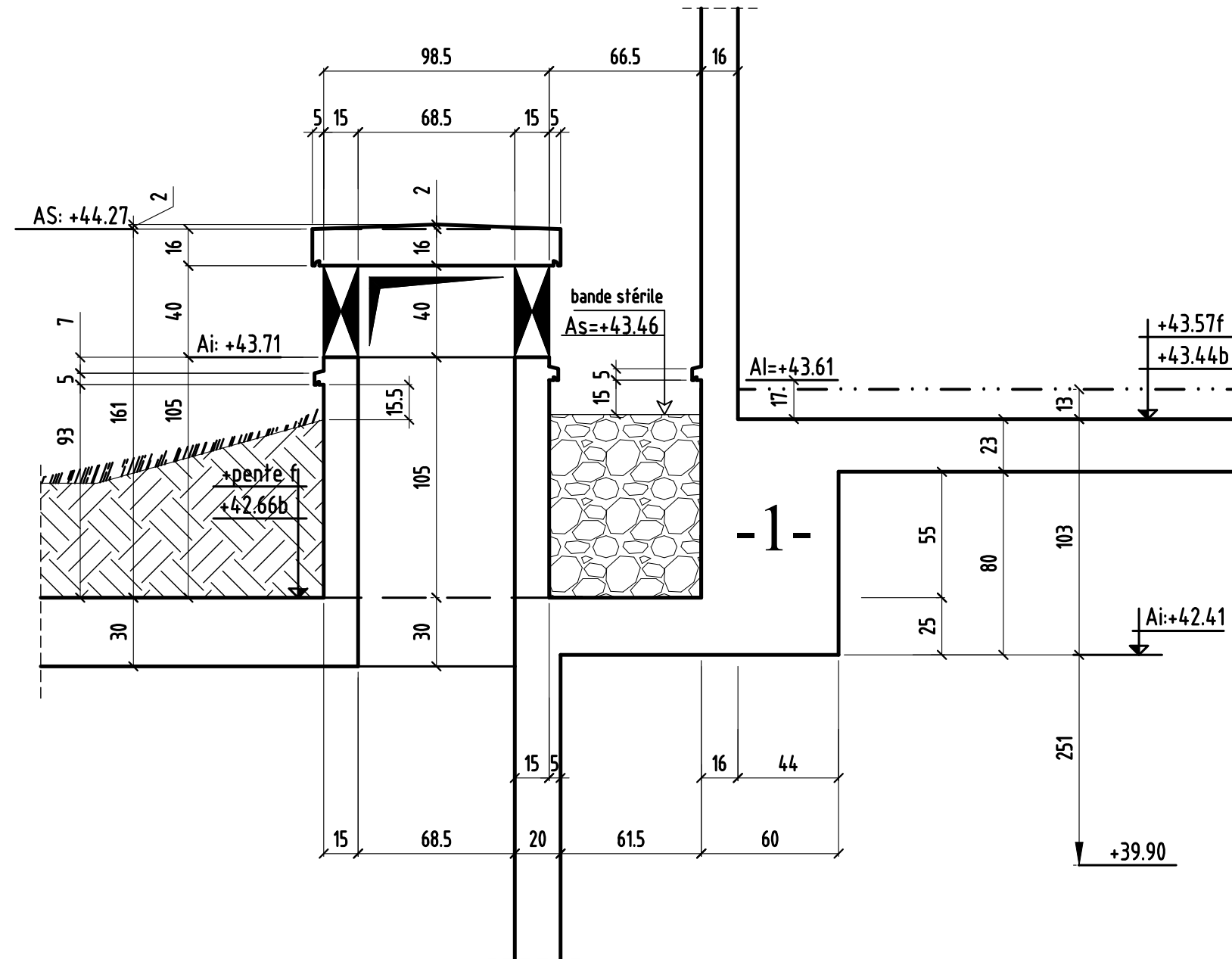

coupe 15-15

0	MODIFICATIONS	A	AFFAIRE:294	Cahier C.08
		B	Ech:1/25	Page 11

# COUPE 16-16

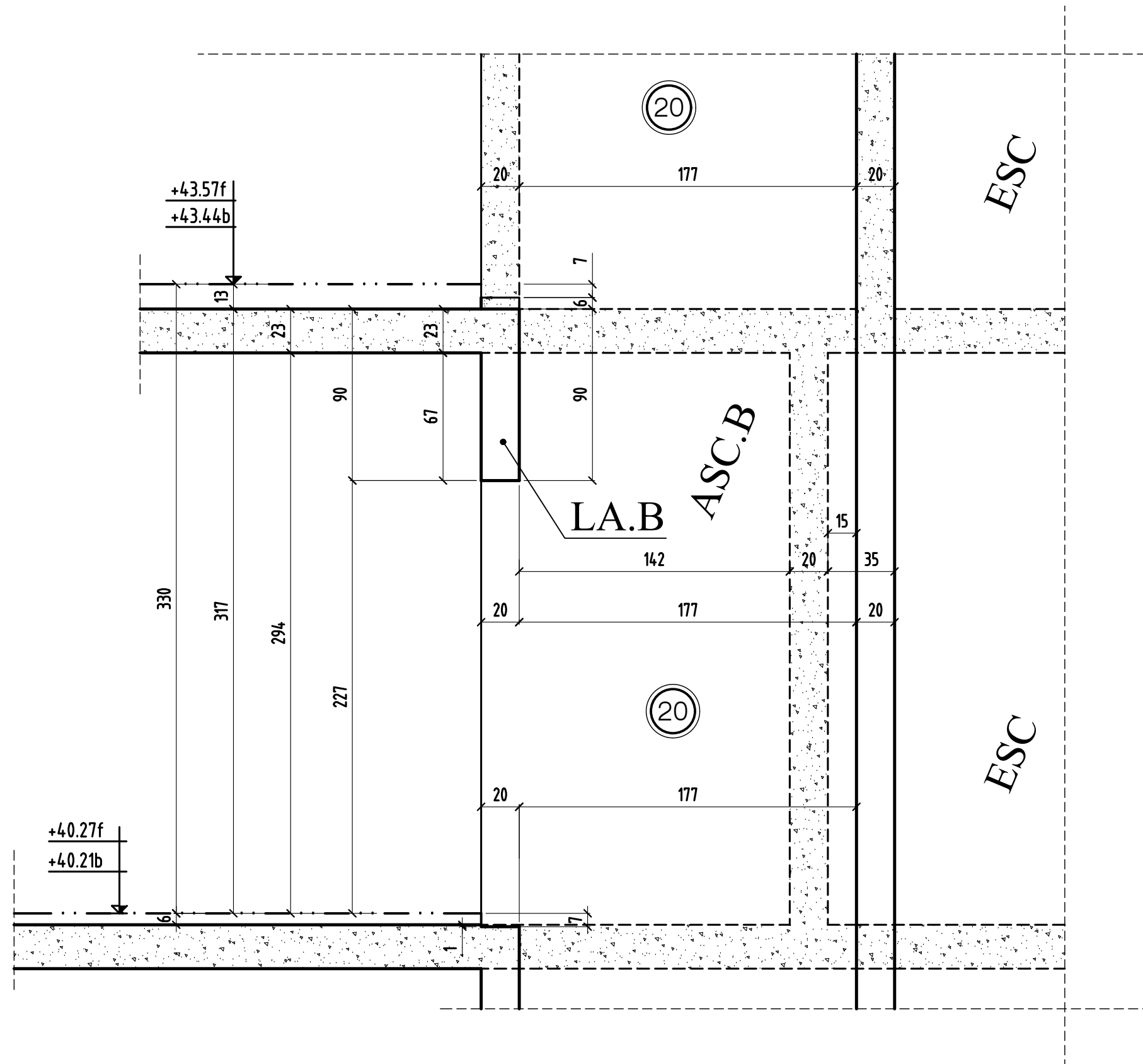

# COUPE 17-17

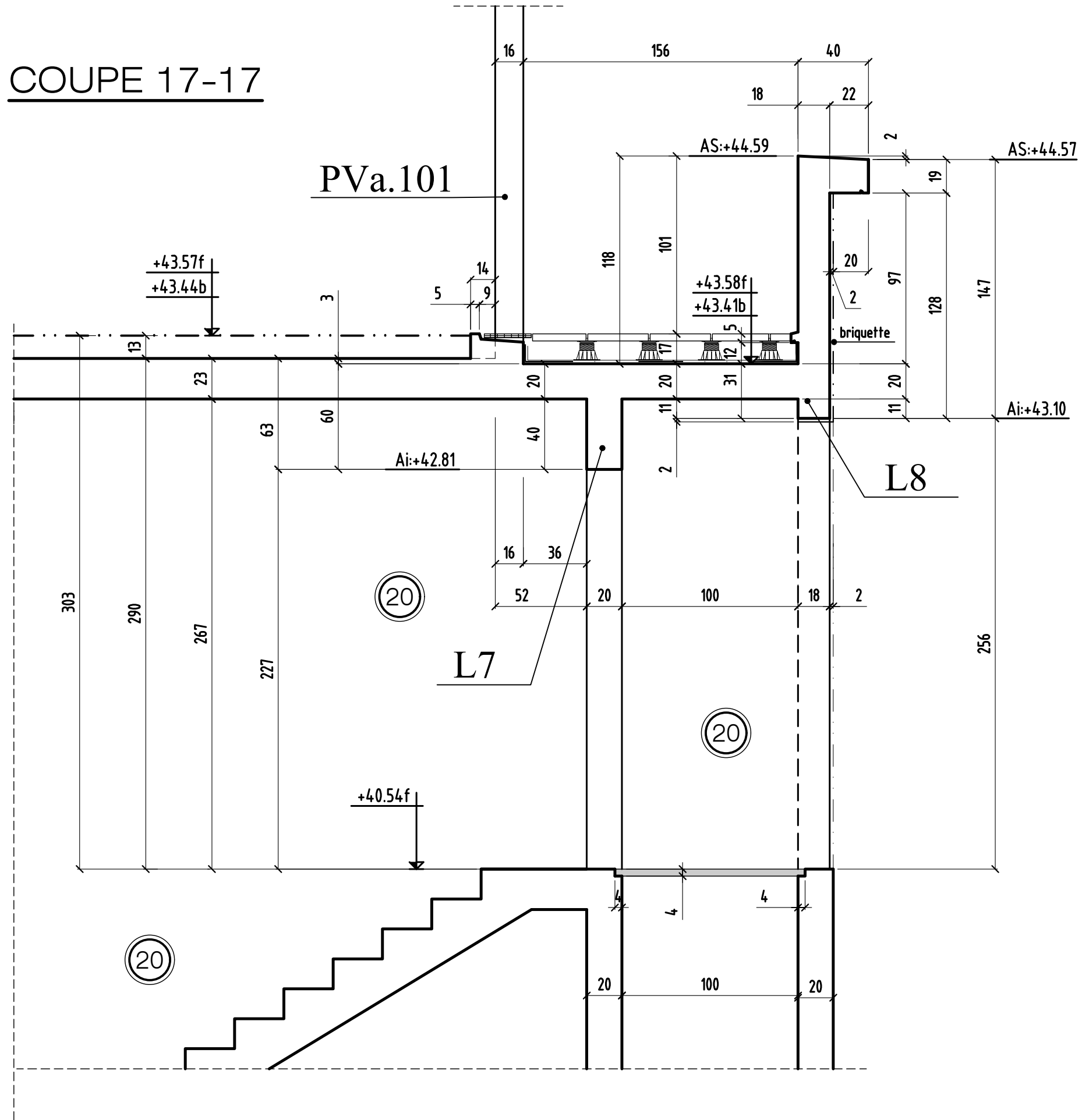

# COUPE 18-18

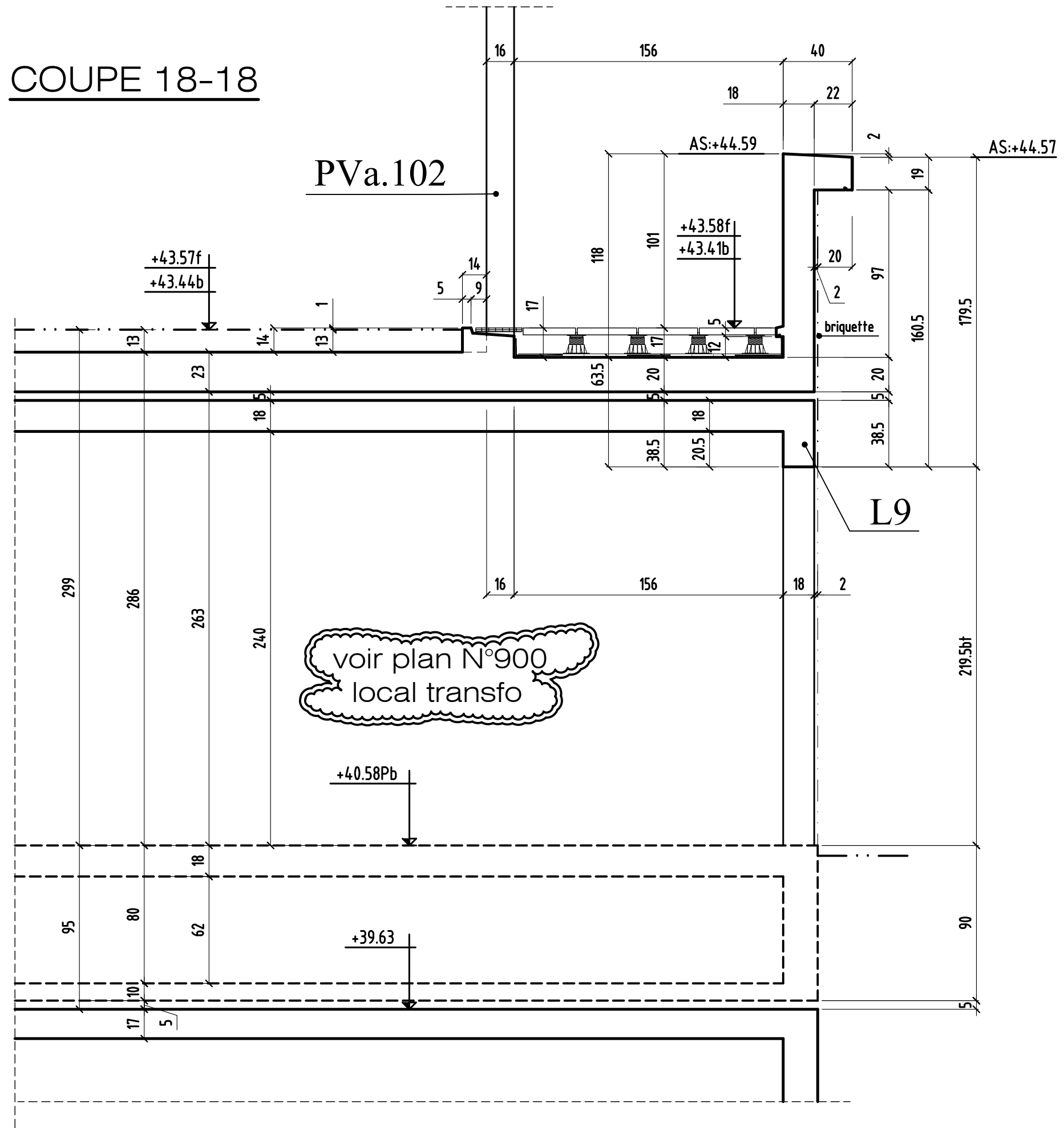

0	MODIFICATIONS	A	AFFAIRE:294	Cahier C.08
		B	Ech:1/25	Page 14

# COUPE 19-19

à confirmer Fenêtre

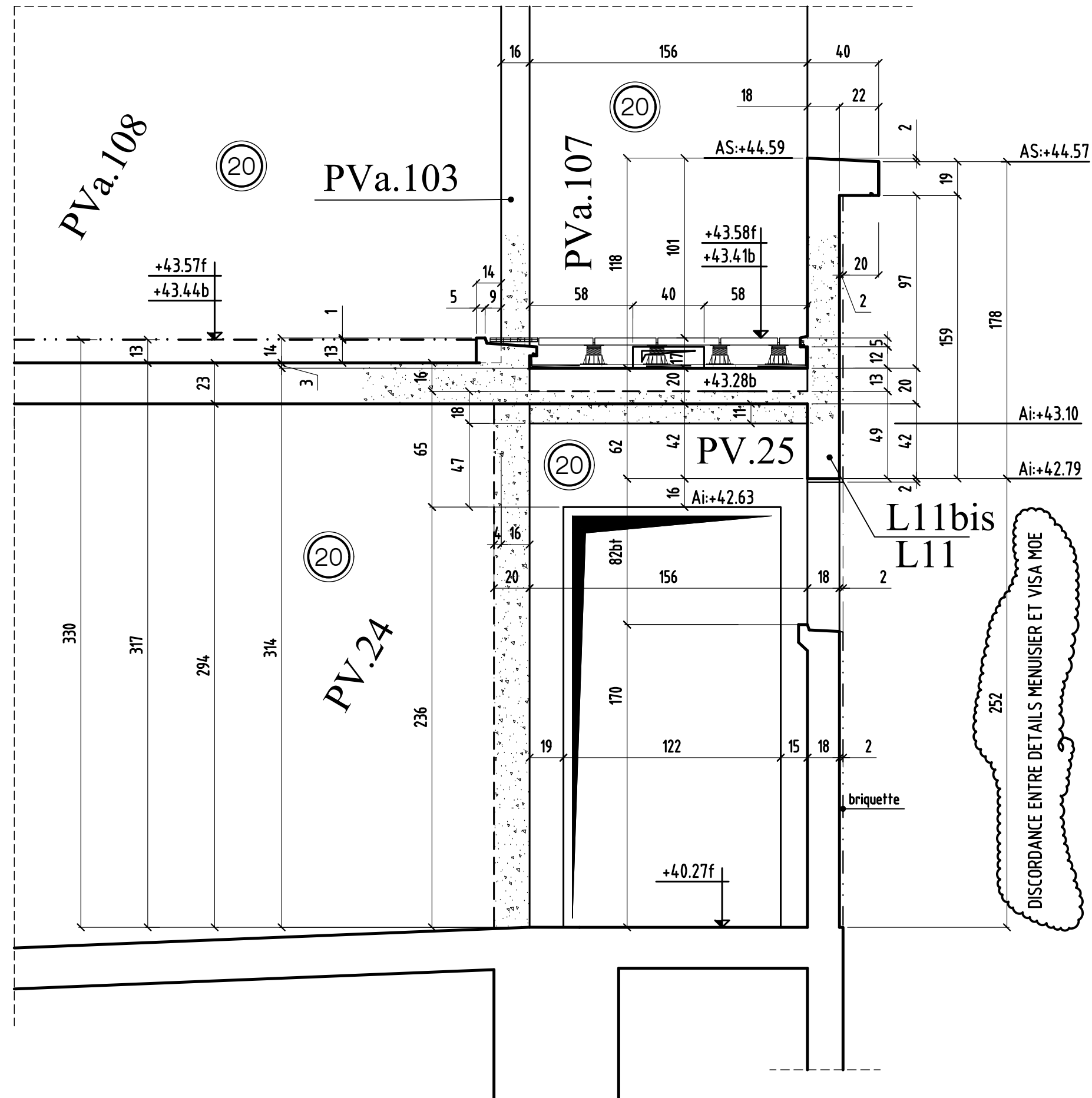

# COUPE 20-20

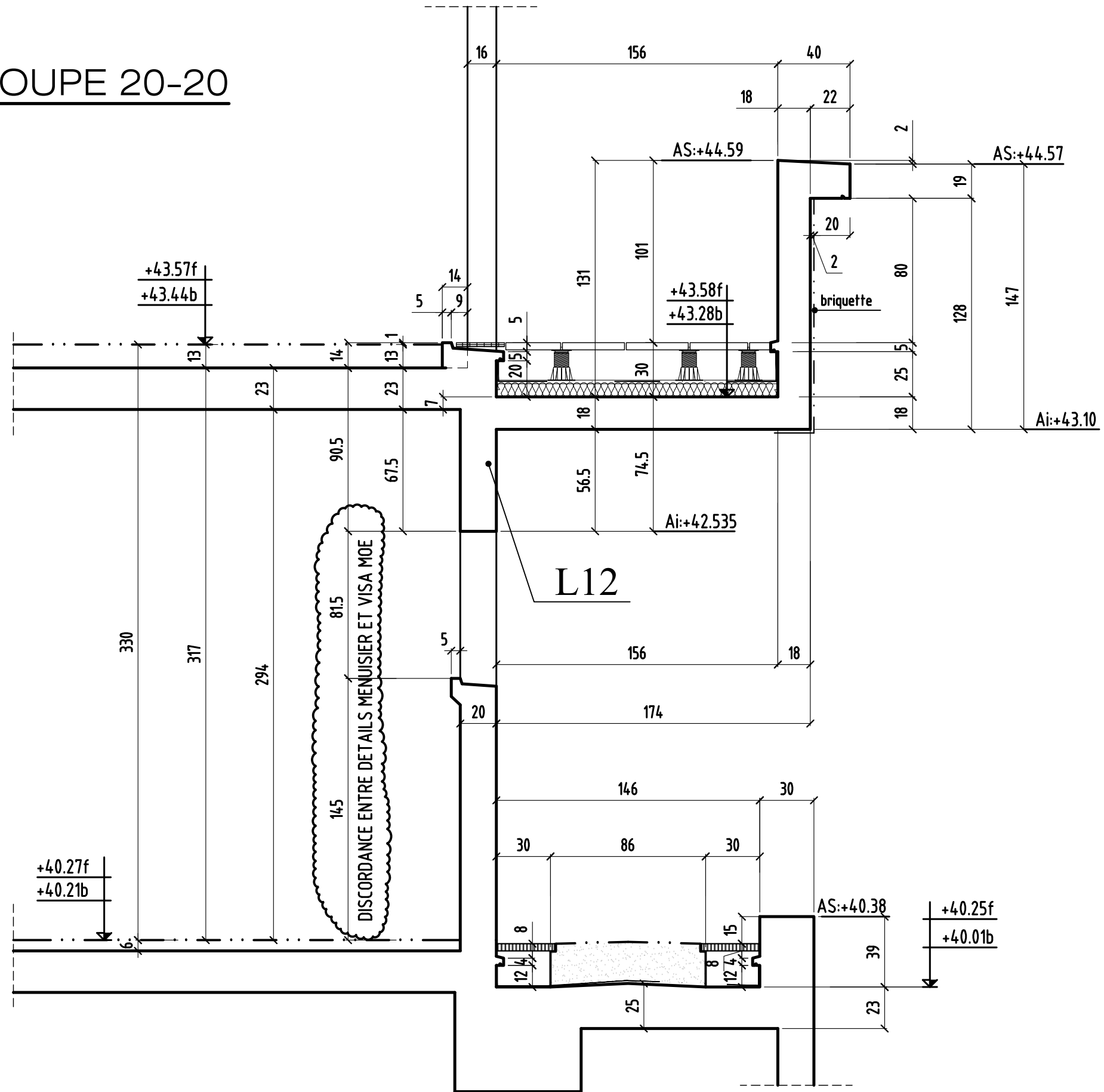

coupe 20-20

	MODIFICATIONS	A	AFFAIRE:294	Cahier C.08
0		B	Ech:1/25	Page 16

# COUPE 21-21

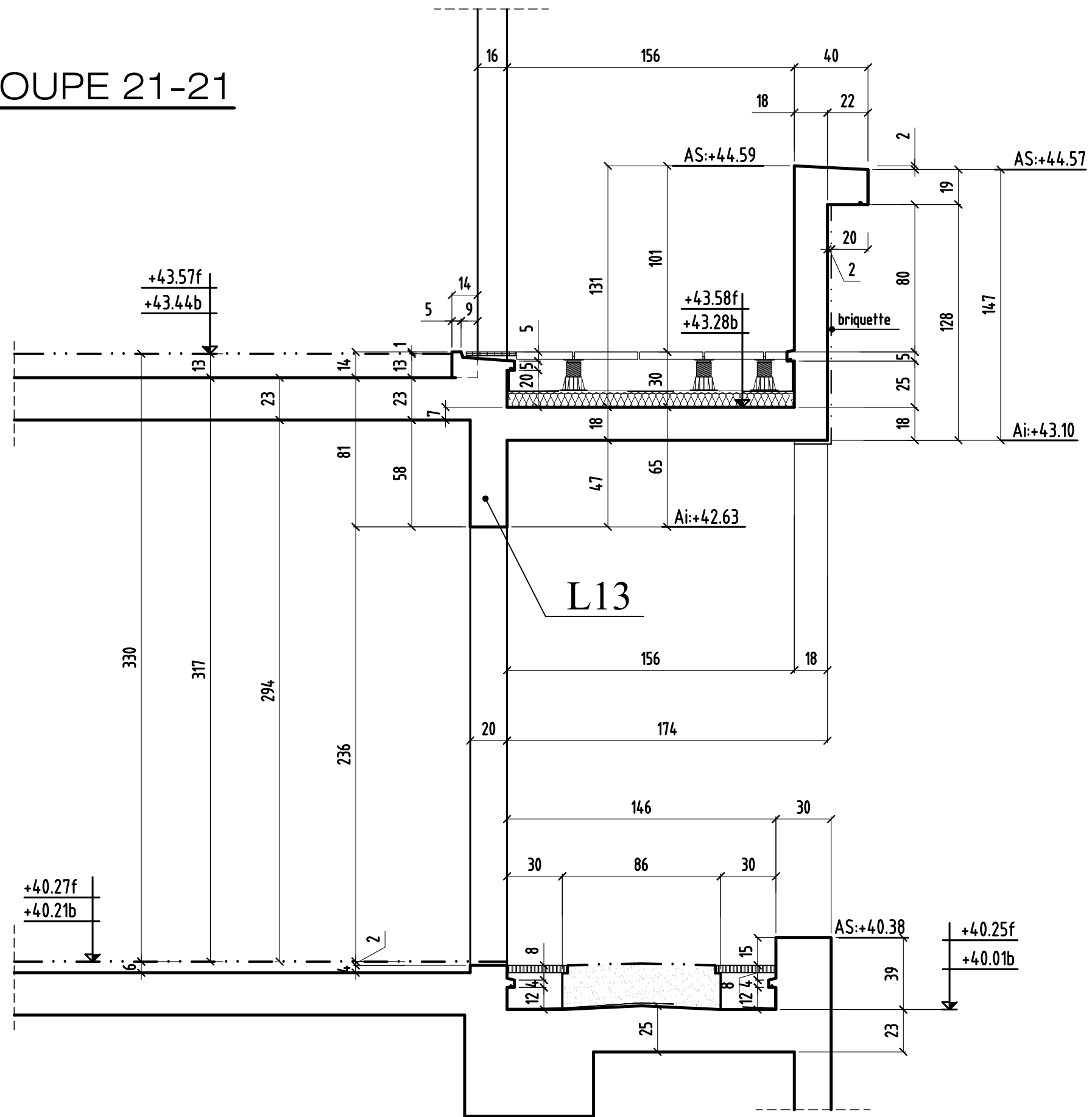

MODIFICATIONS	
0	

A
B

### COUPE 48-48

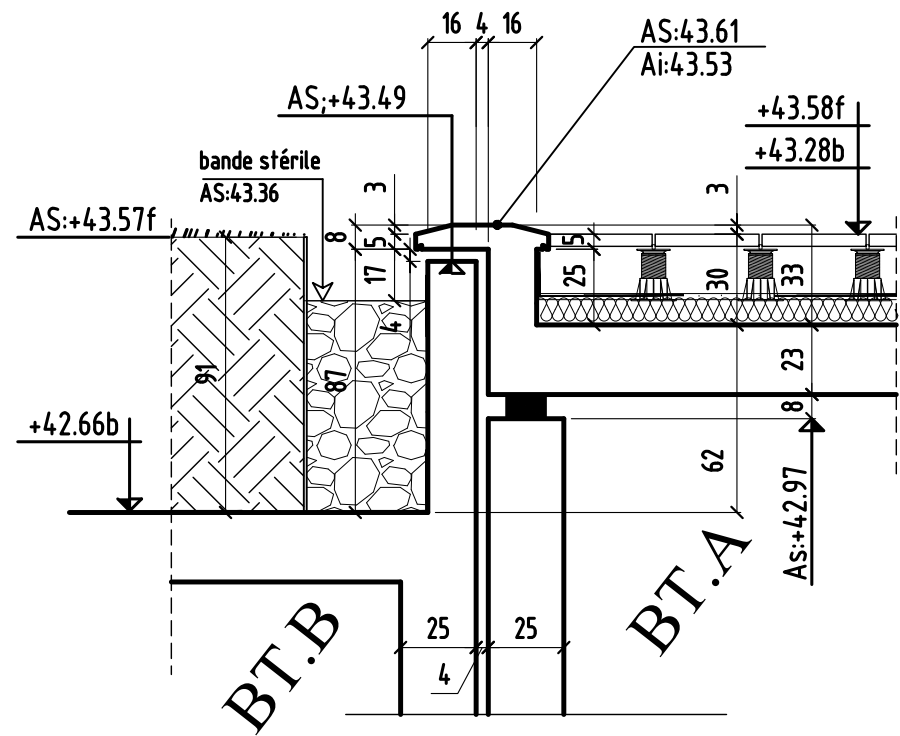

### COUPE 49-49

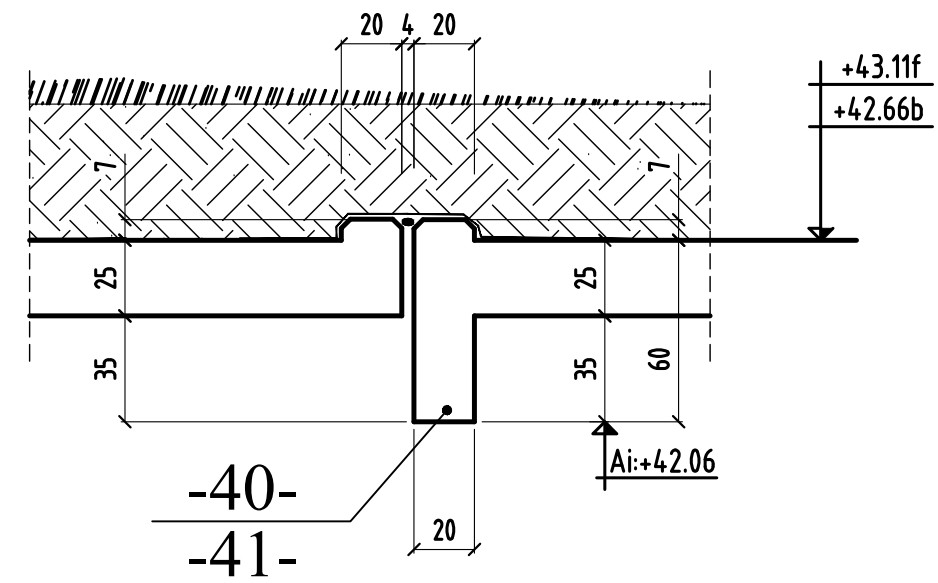

### COUPE 50-50

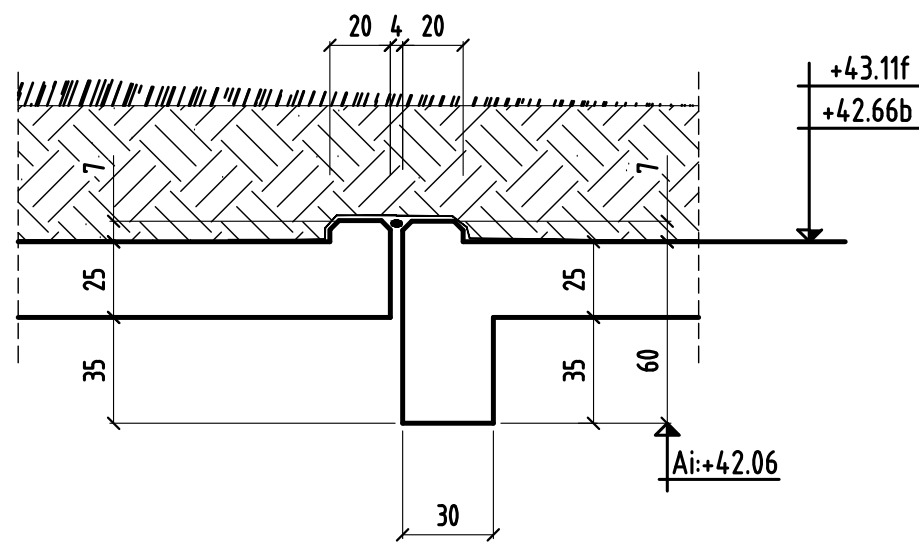

### COUPE 52-52

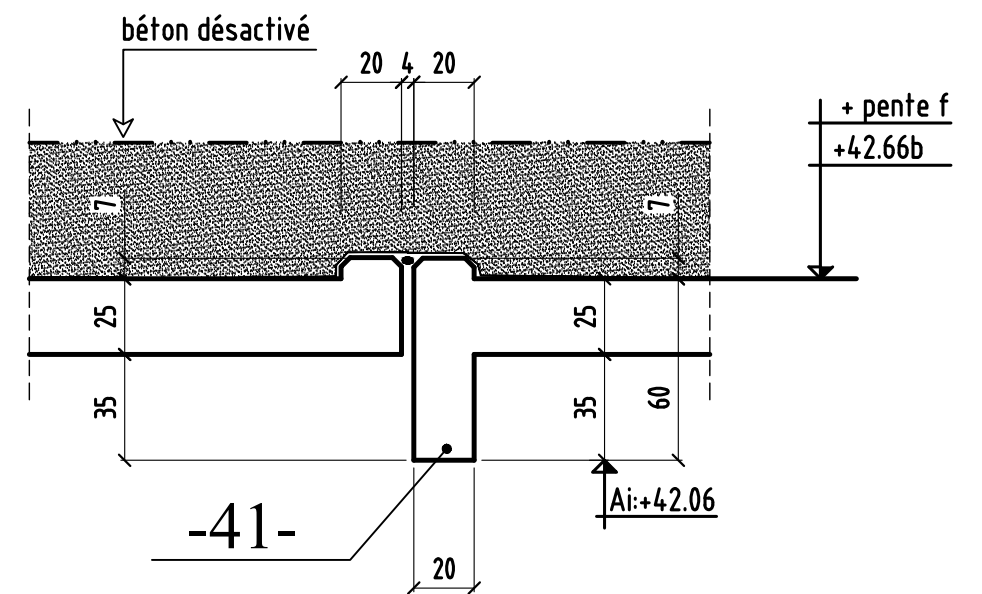



### COUPE a - a

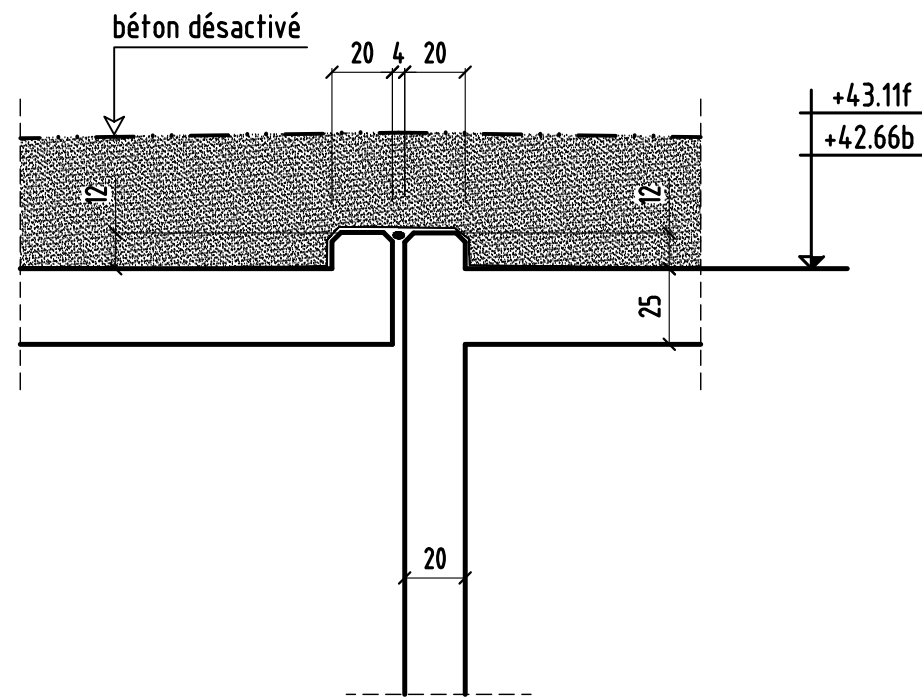

### COUPE b-b

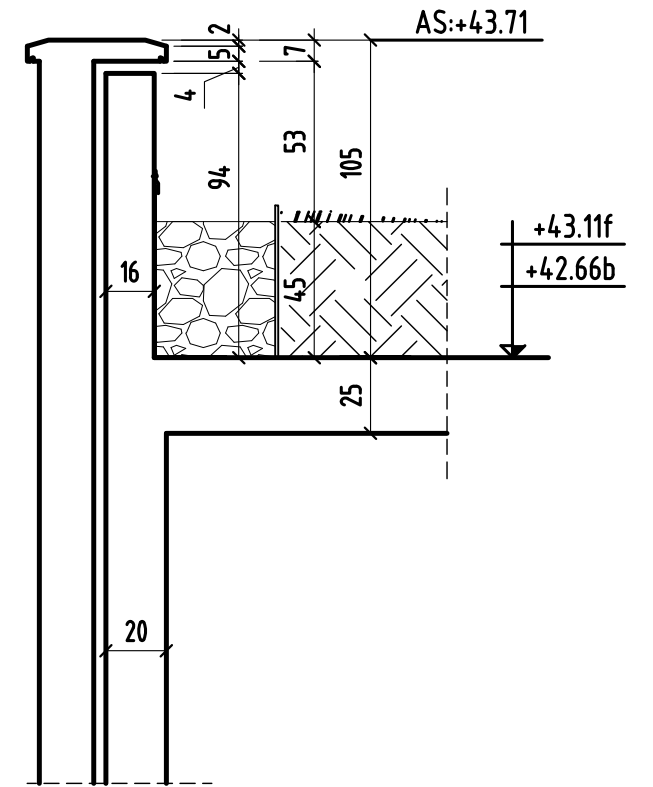

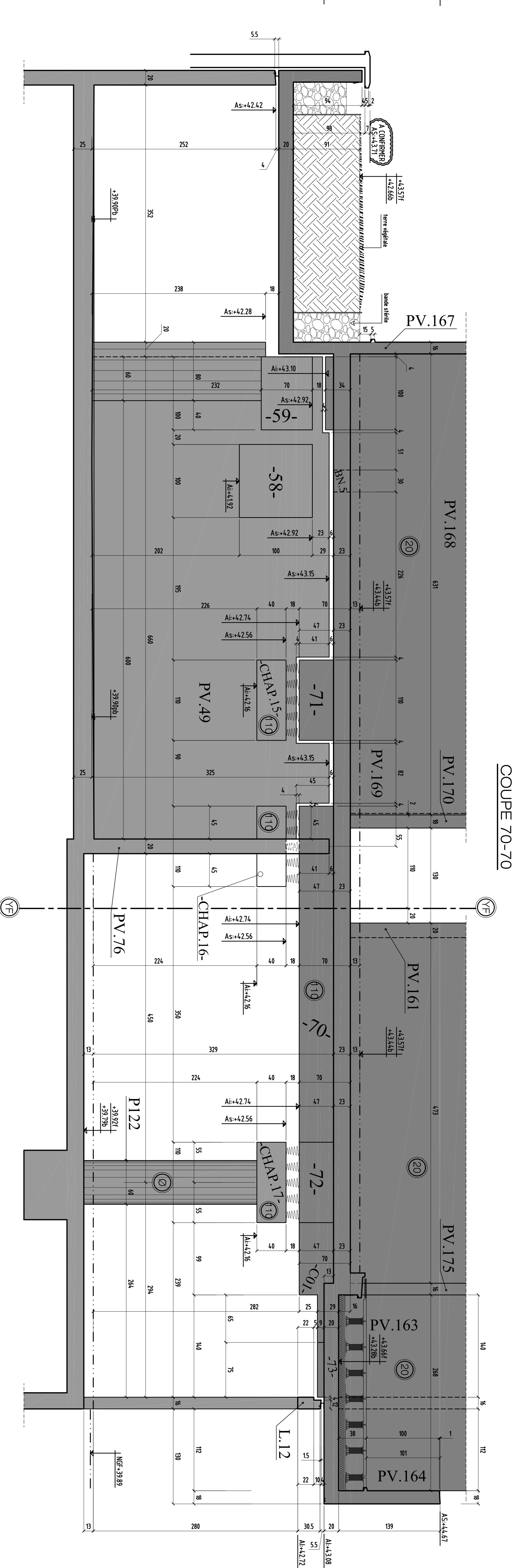
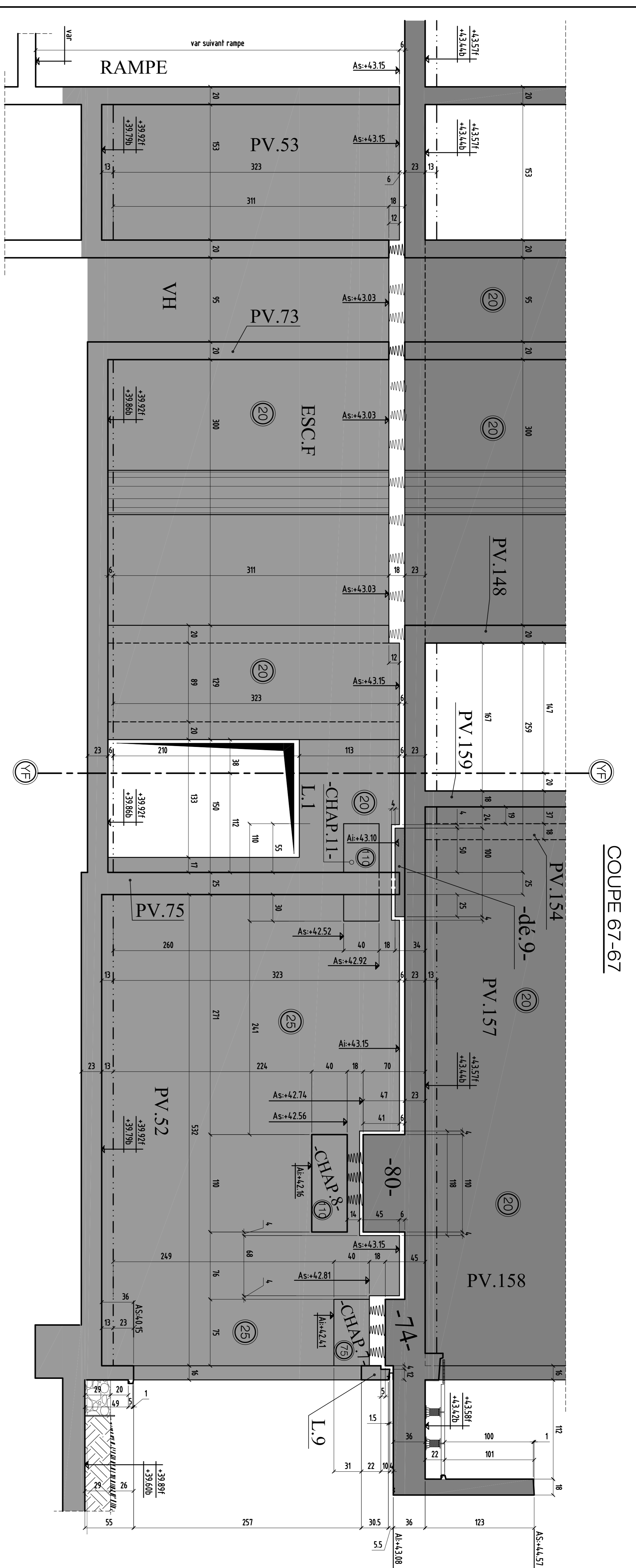

COUPE 74-74

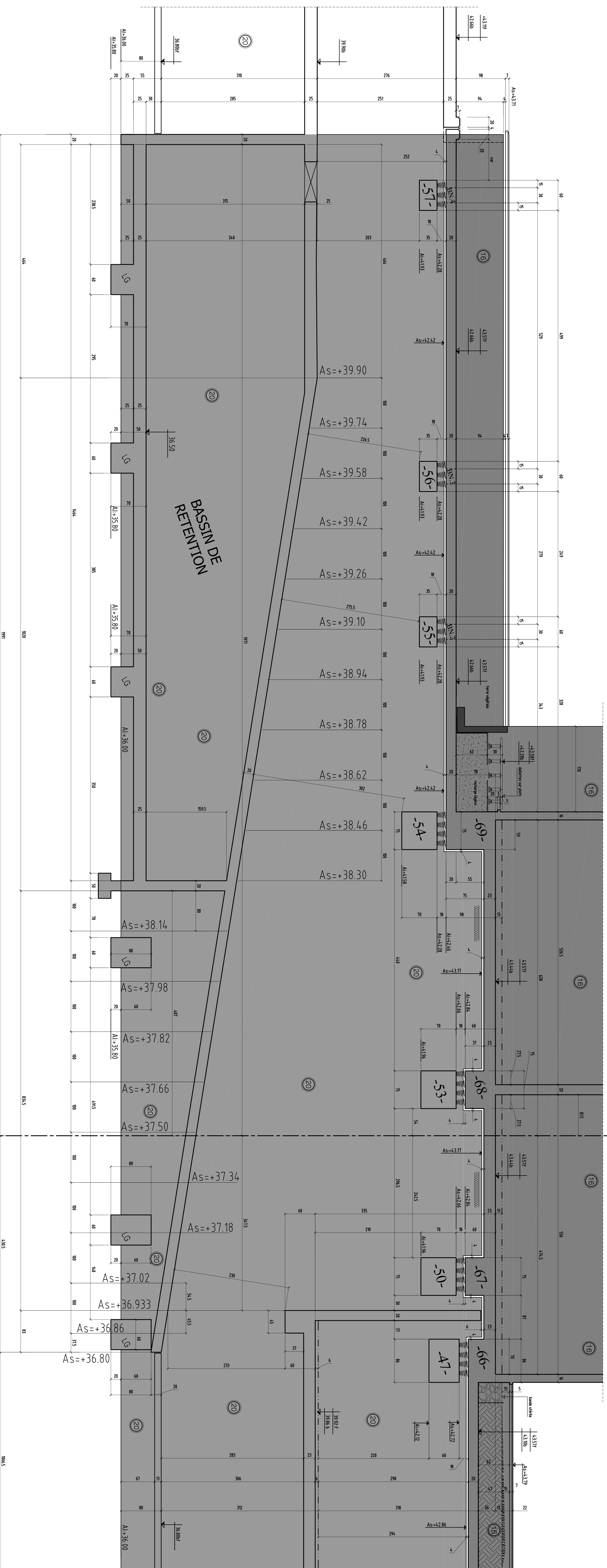

VOIR PLAN N° C.35 - Coupes et détails

COUPE ET DÉTAILS	
<b>COUPE ET DÉTAILS</b>	1:20
<b>ÉCHELLE</b>	1:20
<b>PROJET</b>	2023
<b>DATE</b>	15/02/23
<b>PROJETANT</b>	BOUYGUES IMMOBILIER
<b>PROJETANT</b>	BOUYGUES IMMOBILIER
<b>PROJETANT</b>	BOUYGUES IMMOBILIER
<b>PROJETANT</b>	BOUYGUES IMMOBILIER
<b>PROJETANT</b>	BOUYGUES IMMOBILIER
<b>PROJETANT</b>	BOUYGUES IMMOBILIER

**CHOISY LE ROI** 94600  
**CONSTRUCTION D'UN ENSEMBLE**  
**DE 107 LOGEMENTS SOCIAUX & commerces**  
 94600 CHOISY LE ROI  
 LOT 1

MAÎTRE D'ŒUVRE  
**BOUYGUES IMMOBILIER**  
 11000 PARIS  
 11000 PARIS  
 11000 PARIS  
 11000 PARIS  
 11000 PARIS  
 11000 PARIS

MAÎTRE D'ŒUVRE  
**BOUYGUES IMMOBILIER**  
 11000 PARIS  
 11000 PARIS  
 11000 PARIS  
 11000 PARIS  
 11000 PARIS  
 11000 PARIS

**COPRAGE - COUPES & DÉTAILS (D)**  
**PI RDC**  
**b/c F**

1.000 2023 1:20  
 294 C.34  
 294 C.34  
 294 C.34

CHOISY LE ROI

94600

**CONSTRUCTION D'UN ENSEMBLE  
DE 107 LOGEMENTS SOCIAUX & commerces  
bts: A & B & F**

94600 CHOISY LE ROI  
ILOT 1

<b>MAITRE D' OEUVRE</b>	<b>MAITRE D'OUVRAGE</b>
<b>CITE ARCHITECTURE</b> 11 RUE FLATTERS 75005 PARIS ☎: 01.48.28.44.10 ☎: 01.48.28.44.18	<b>BOUYGUES IMMOBILIER</b> 27, avenue des Murs du Parc 94300 Vincennes ☎: 01.58.64.53.54 ☎: 01.58.64.53.03
<b>BUREAU DE CONTROLE</b>	<b>ENTREPRISE G.O.</b>
<b>QUALICONSULT</b> 127/121 chemin des Bassins 93035 CRETEIL ☎: 01.49.56.06.00 ☎: 01.48.71.85.81	<b>M.T.R</b> 9, rue René Cassin 77173 CHEVRY-COSSIGNY ☎: 01.60.62.32.00 ☎: 01.60.62.32.01

**COFFRAGE - COUPES & DETAILS (I)**  
*Pht RDC*  
*bt: F*

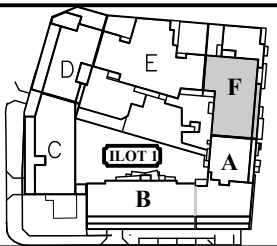

ind.	date	modifications
0	15-12-17	1 ère diffusion.

	DOSSIER		PLAN		APD
	294		C.35		IND.
					EXE
	Ingenieur		Projeteur	Date	Echelle
		H.B.E	15/02/17	1/25	

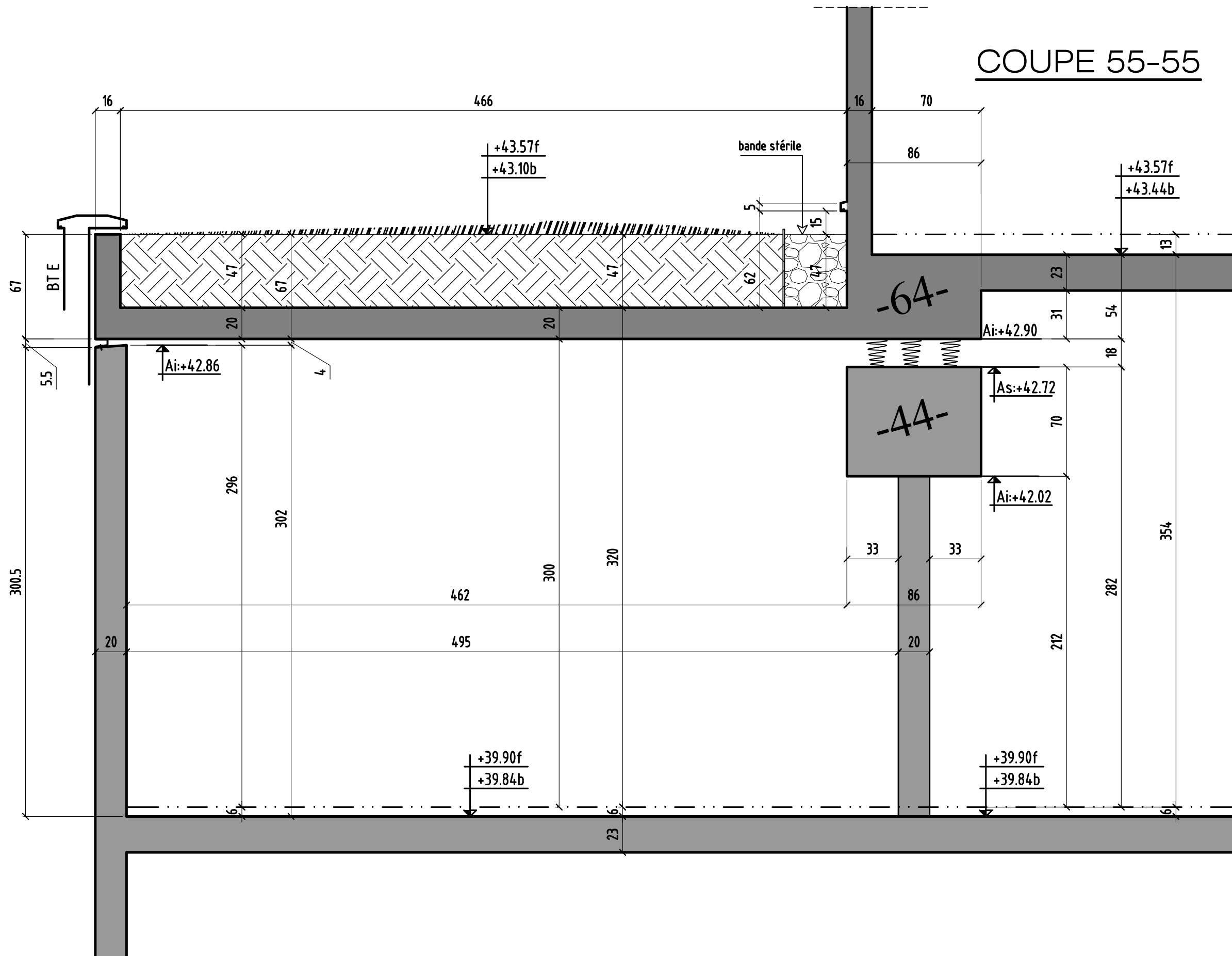

COUPE 55-55

coupe 55-55

0	MODIFICATIONS	A	AFFAIRE:294	Cahier C.35
		B	Ech:1/25	Page 01

# COUPE 56-56

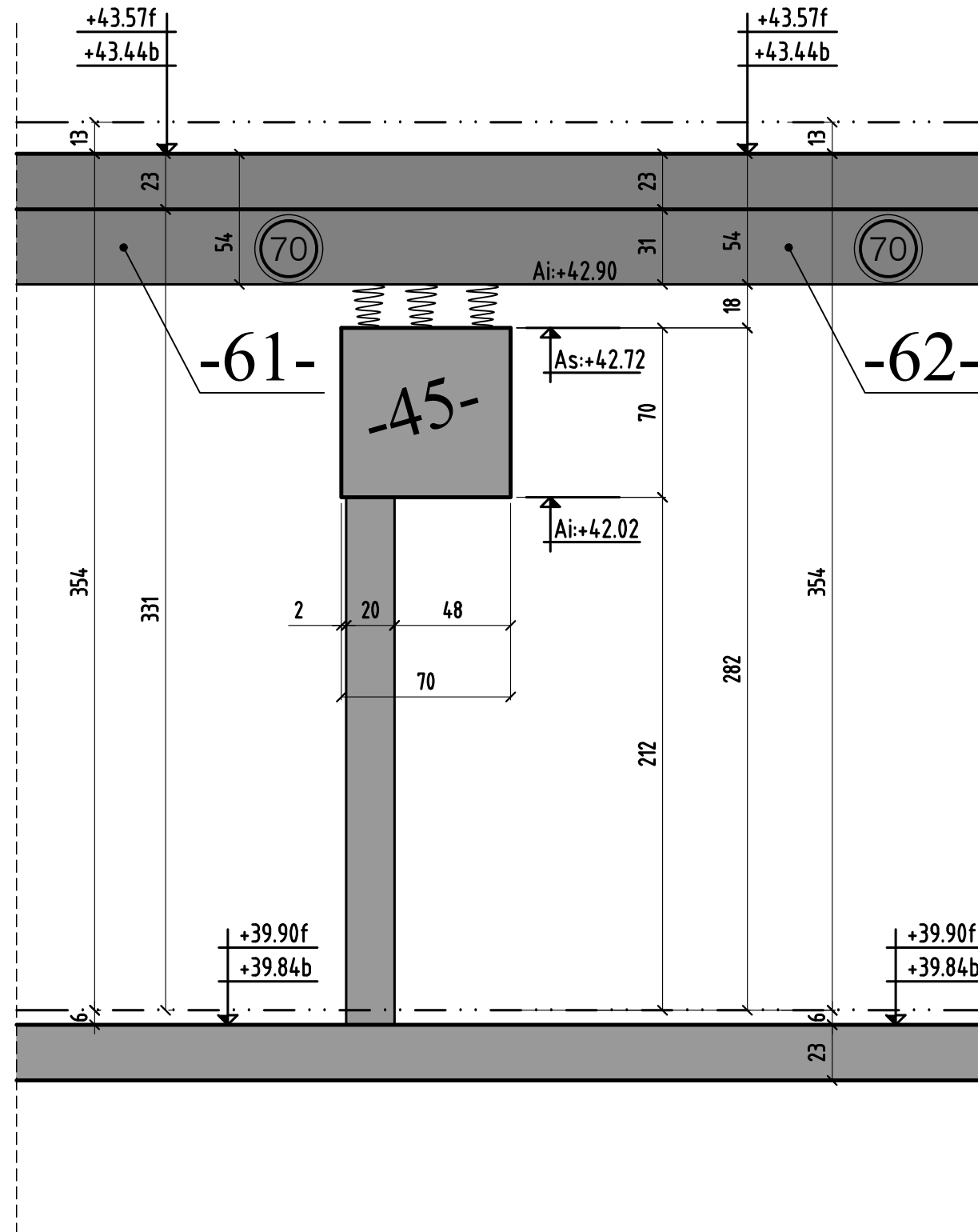

0	MODIFICATIONS	A	AFFAIRE:294	Cahier C.35
		B	Ech:1/25	Page 02

# COUPE 57-57

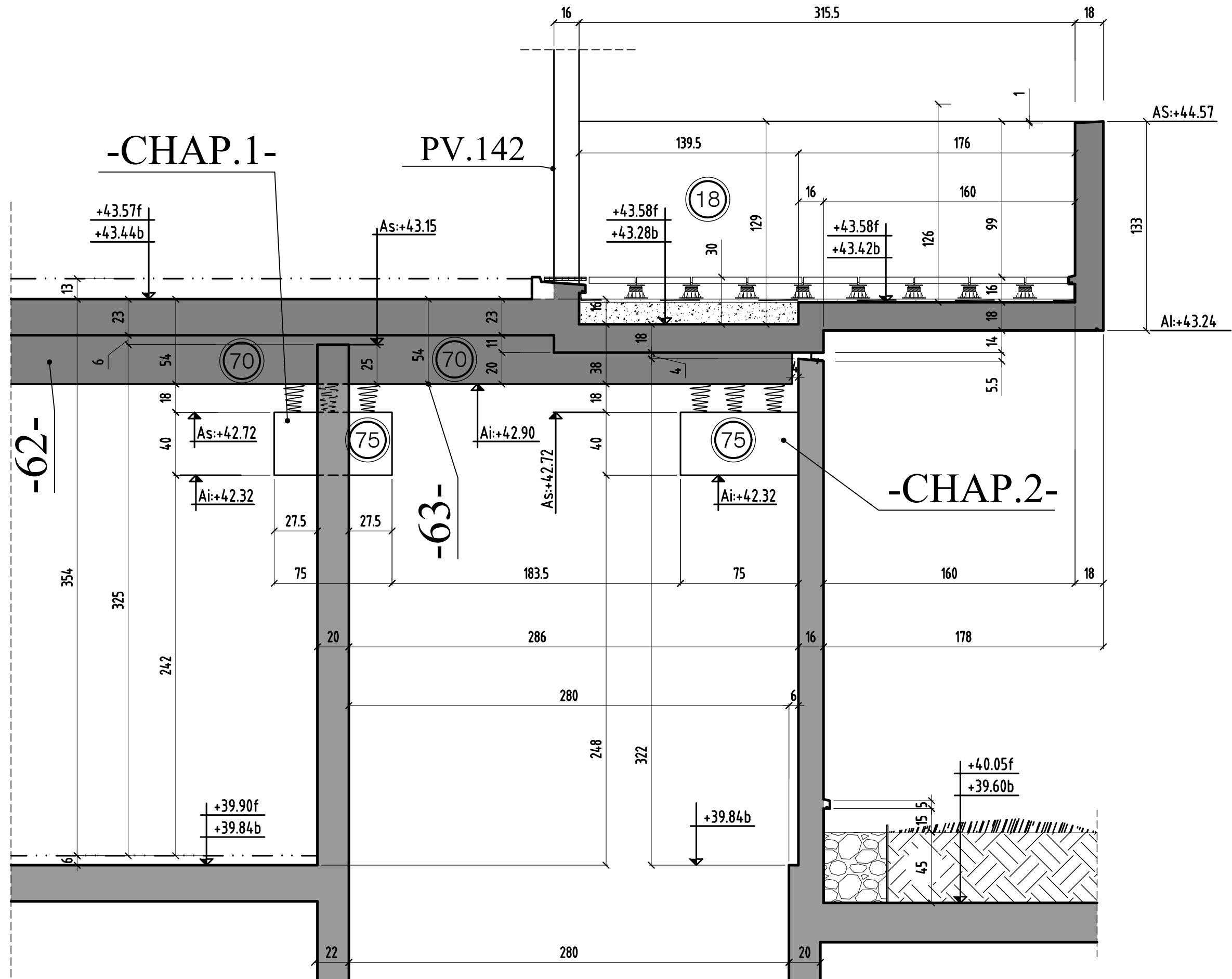

coupe 57-57

MODIFICATIONS

A

AFFAIRE:294

Cahier C.35

0

B

Ech:1/25

Page 03

# COUPE 58-58

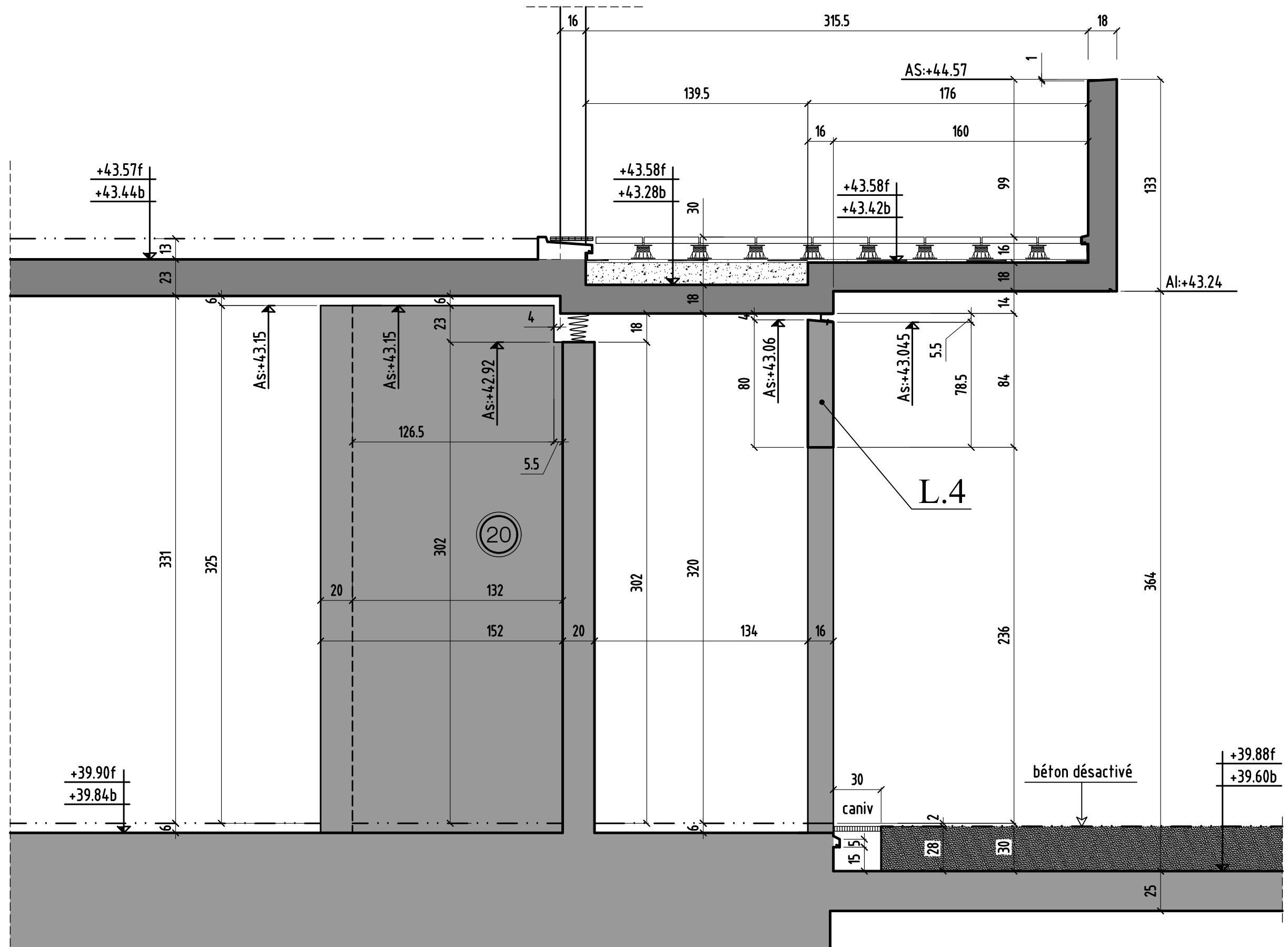

coupe 58-58

0	MODIFICATIONS	A	AFFAIRE:294	Cahier C.35
		B	Ech:1/25	Page 04

COUPE 59-59

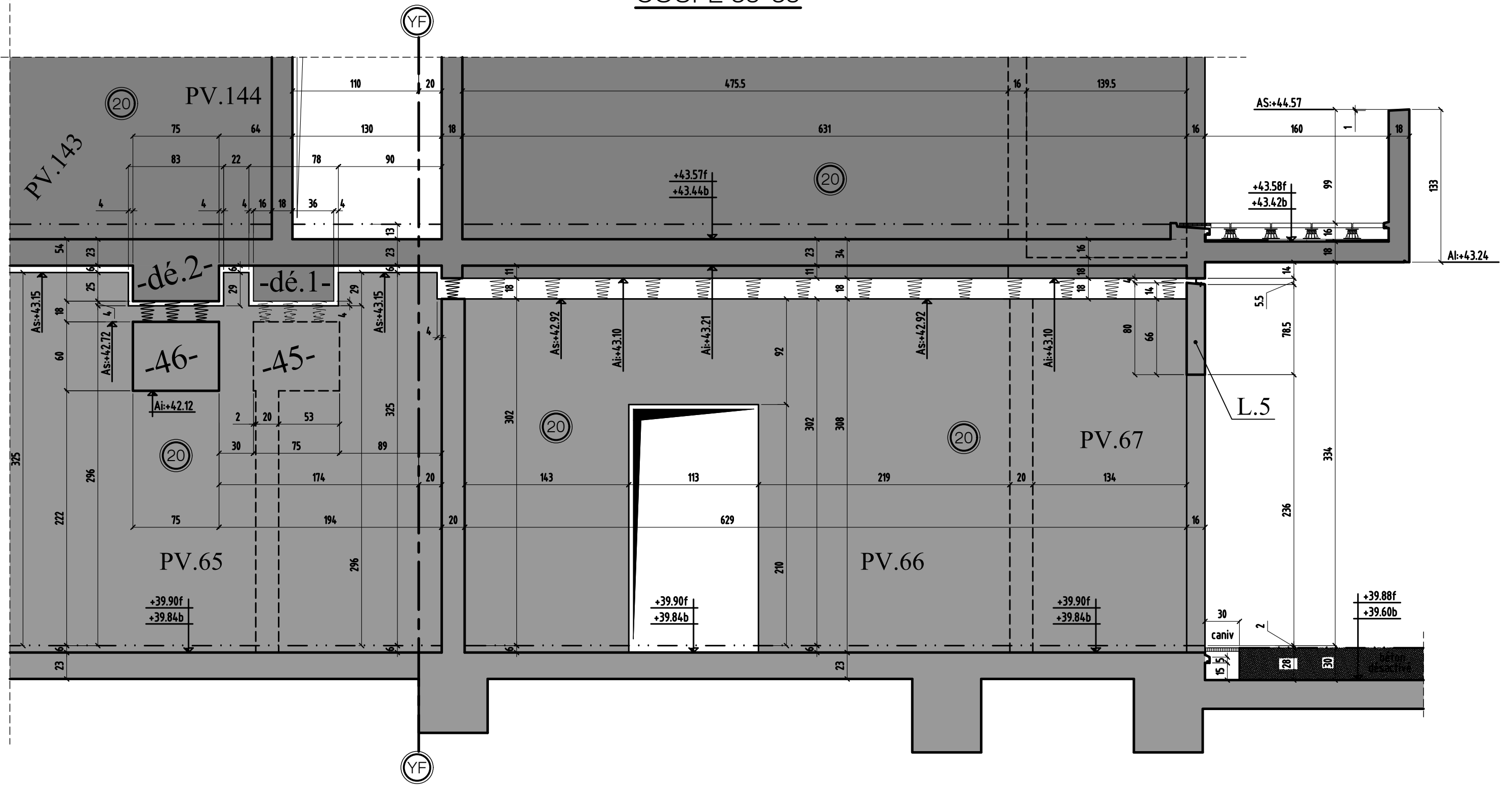

0	MODIFICATIONS	A	AFFAIRE:294	Cahier C.35
		B	Ech: DIVERS	Page 05



# COUPE 60-60

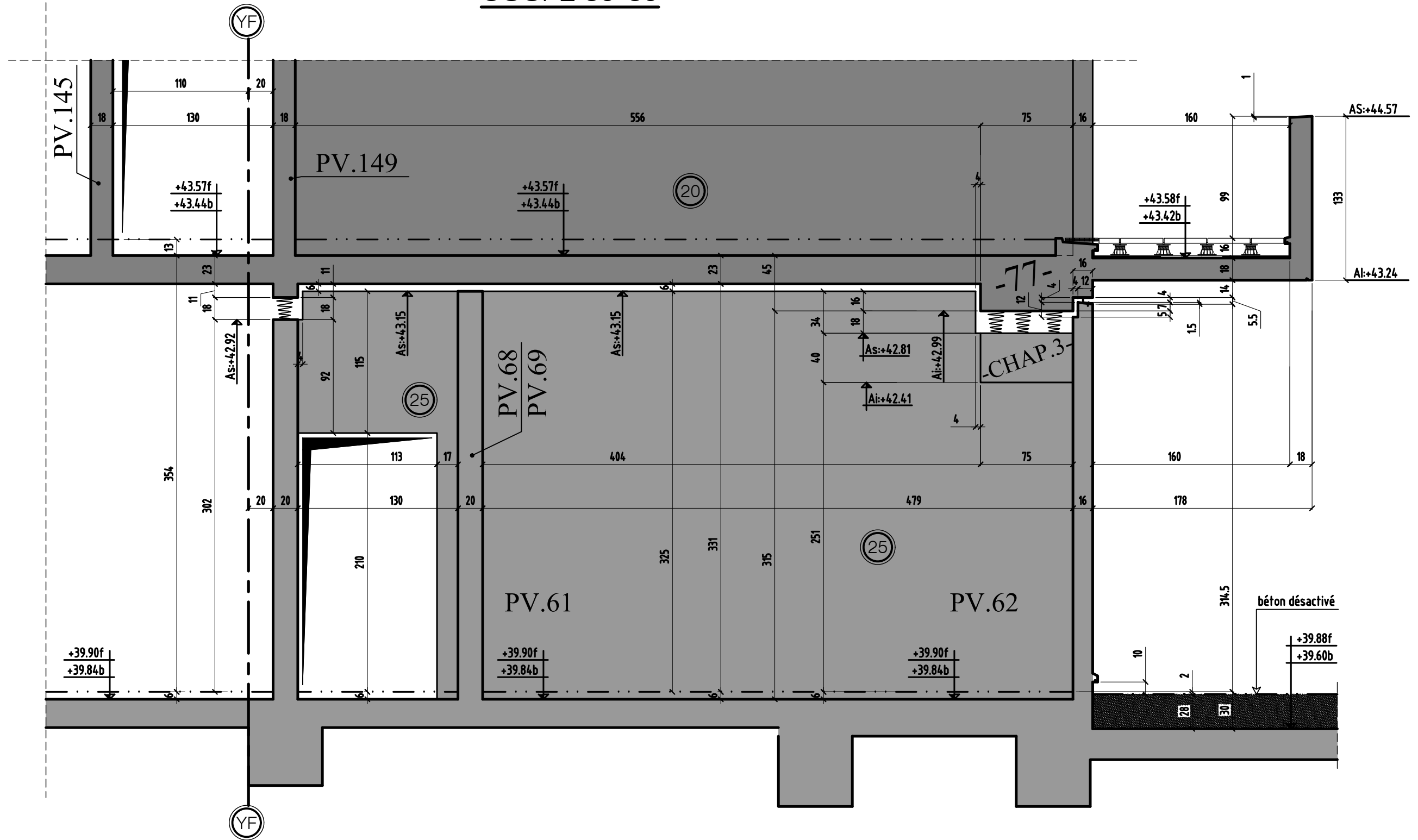

coupe 60-60

MODIFICATIONS

A

AFFAIRE:294

Cahier C.35

0

B

Ech:1/25

Page 06

# COUPE 61-61

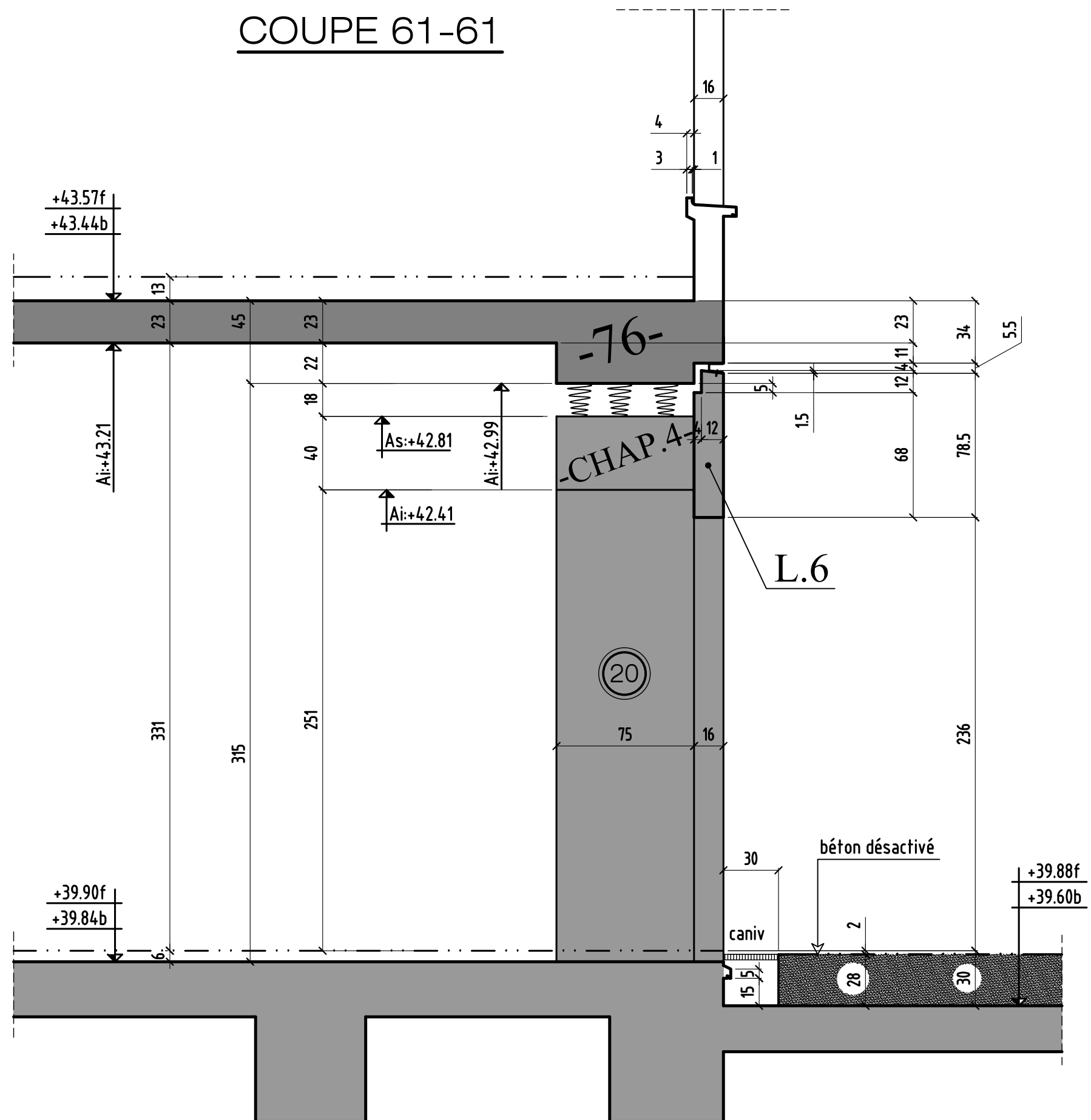

coupe 61-61

MODIFICATIONS

A  
B

AFFAIRE:294

Ech:1/25

Cahier C.35

Page 07

# COUPE 62-62

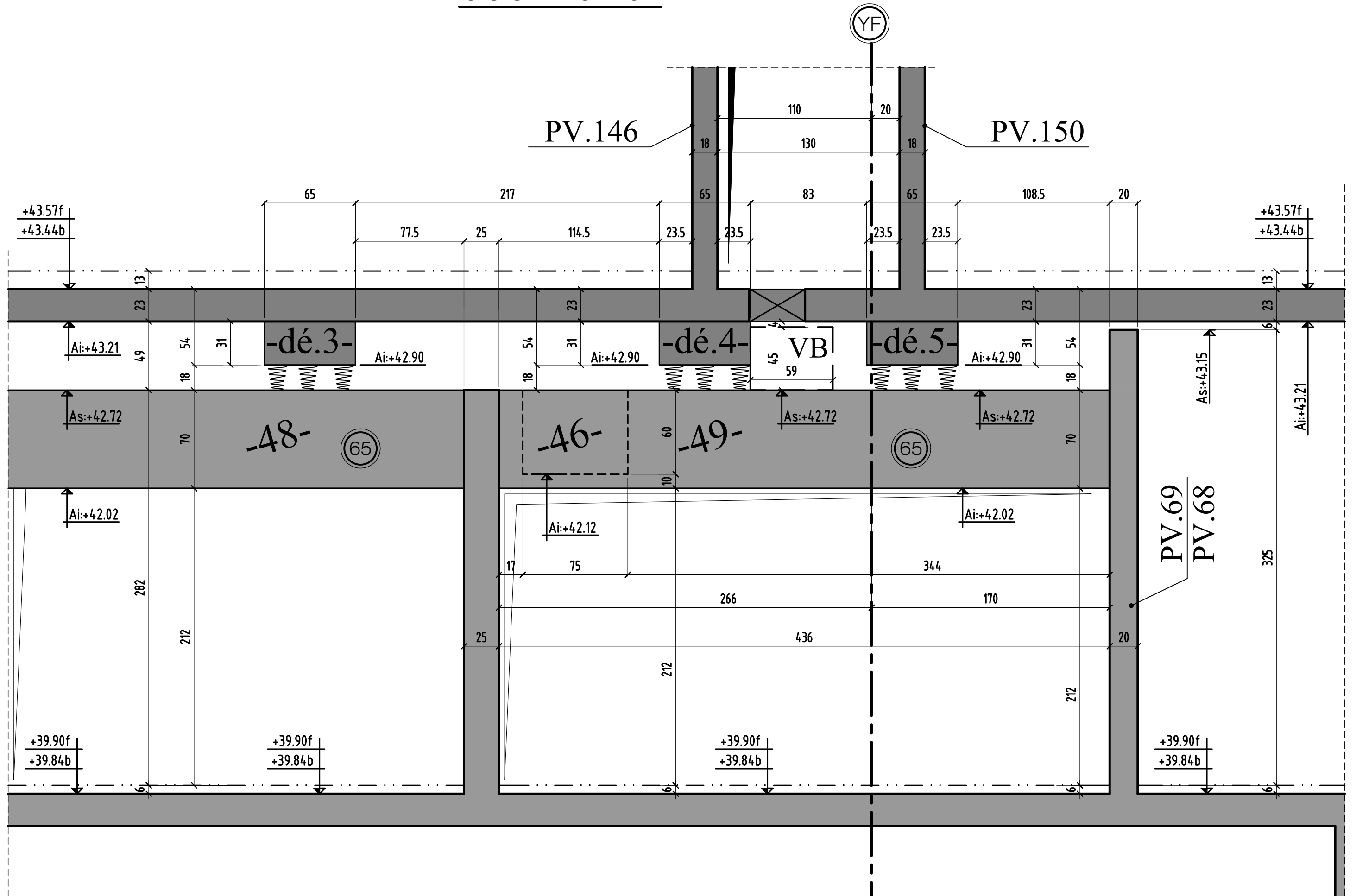

coupe 62-62

MODIFICATIONS

A

AFFAIRE:294

Cahier C.35

0

B

Ech:1/25

Page 08

# COUPE 63-63

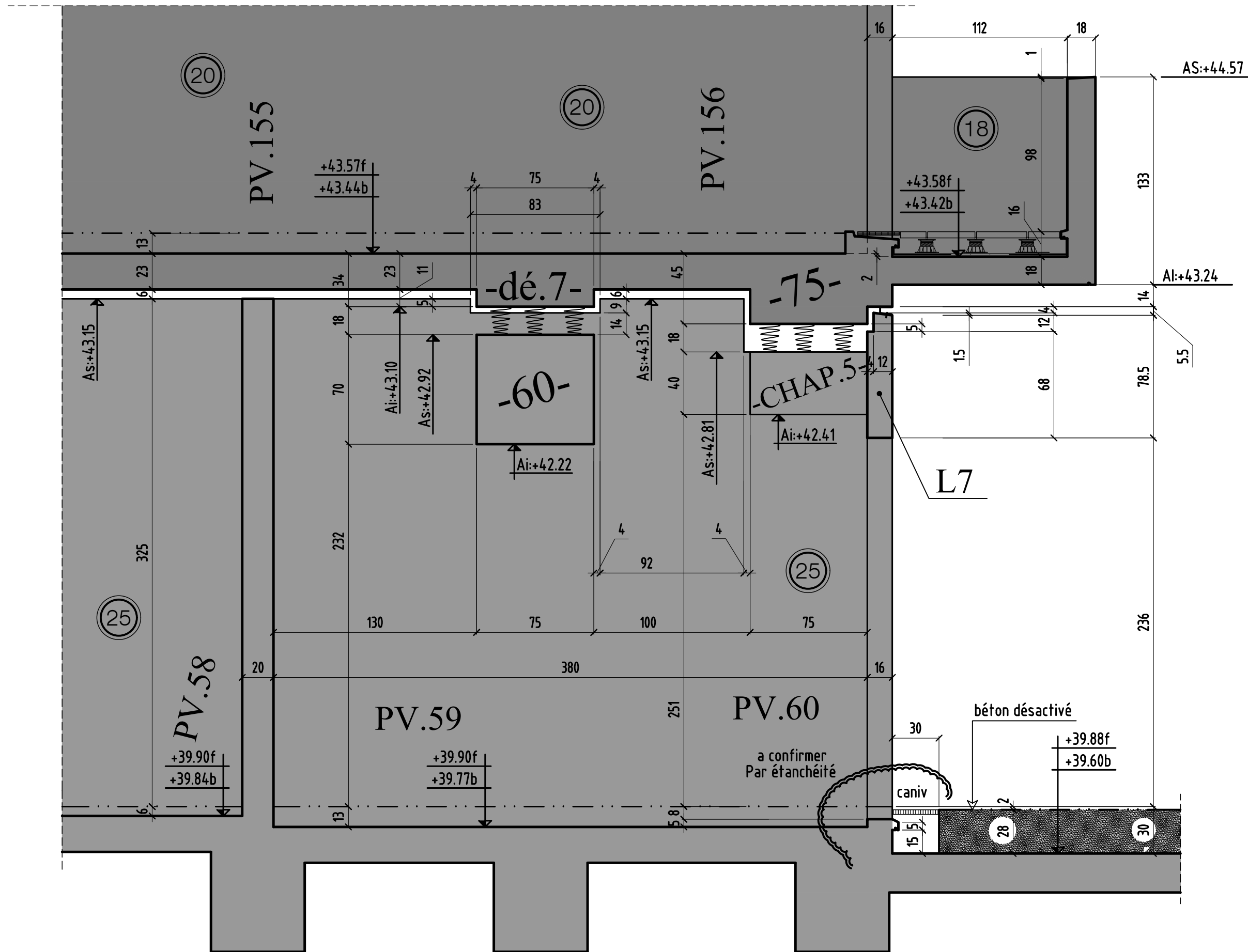

COUPE 64-64

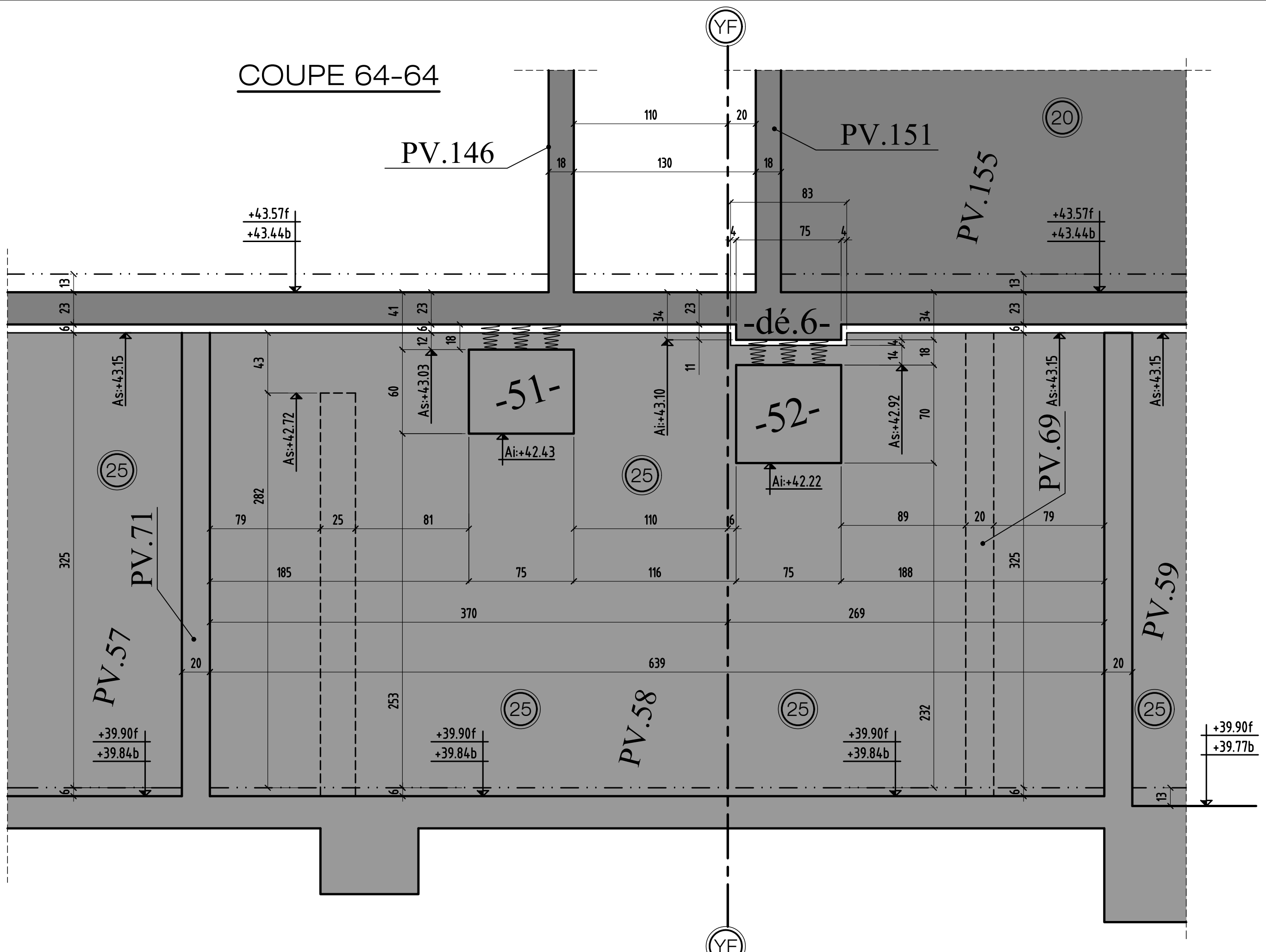

coupe 64-64

MODIFICATIONS

A  
B

AFFAIRE:294

Ech:1/25

Cahier C.35

Page 10

# COUPE 65-65

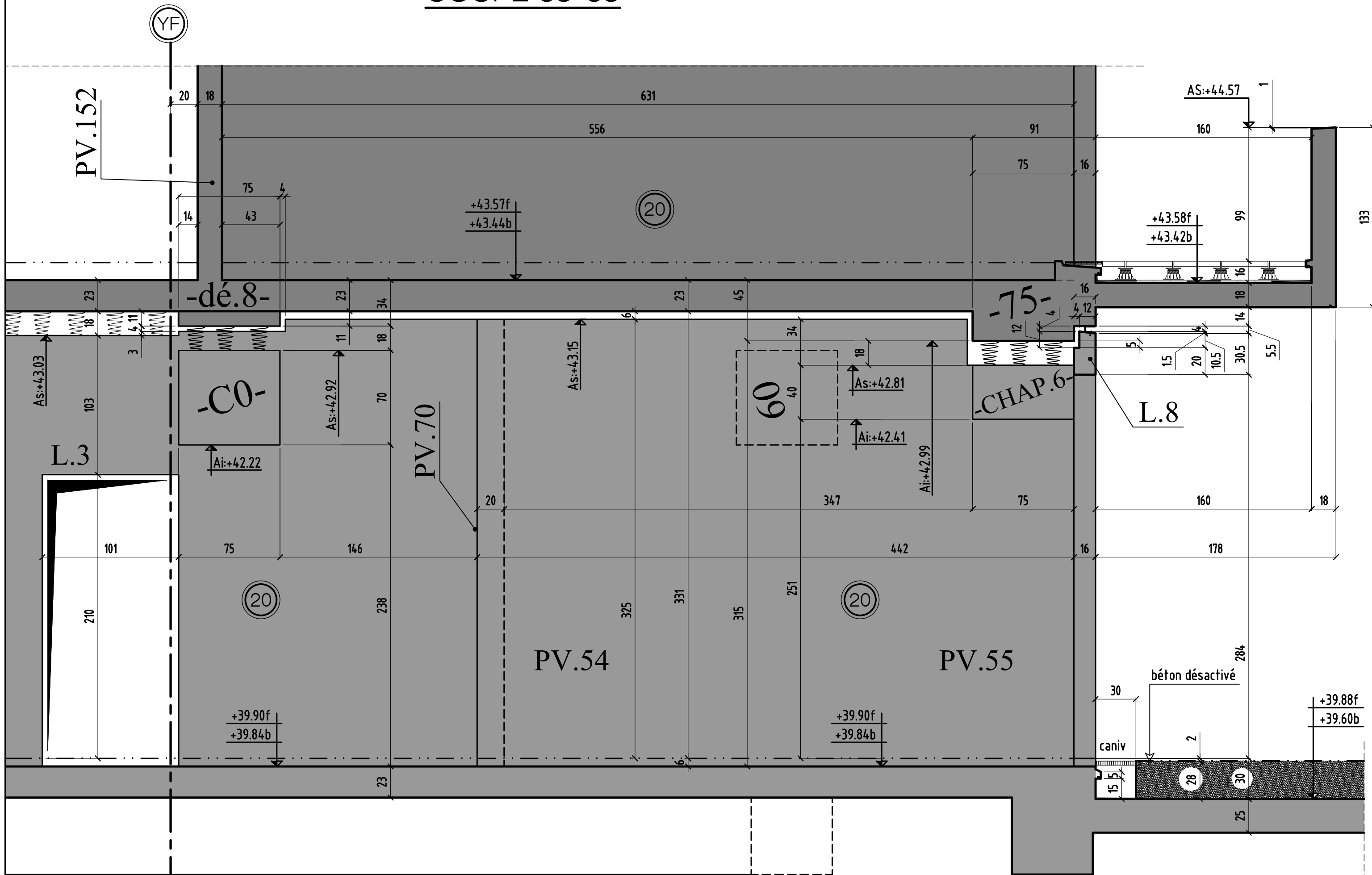

coupe 65-65

MODIFICATIONS

A

AFFAIRE:294

Cahier C.35

0

B

Ech:1/25

Page 10

# COUPE 66-66

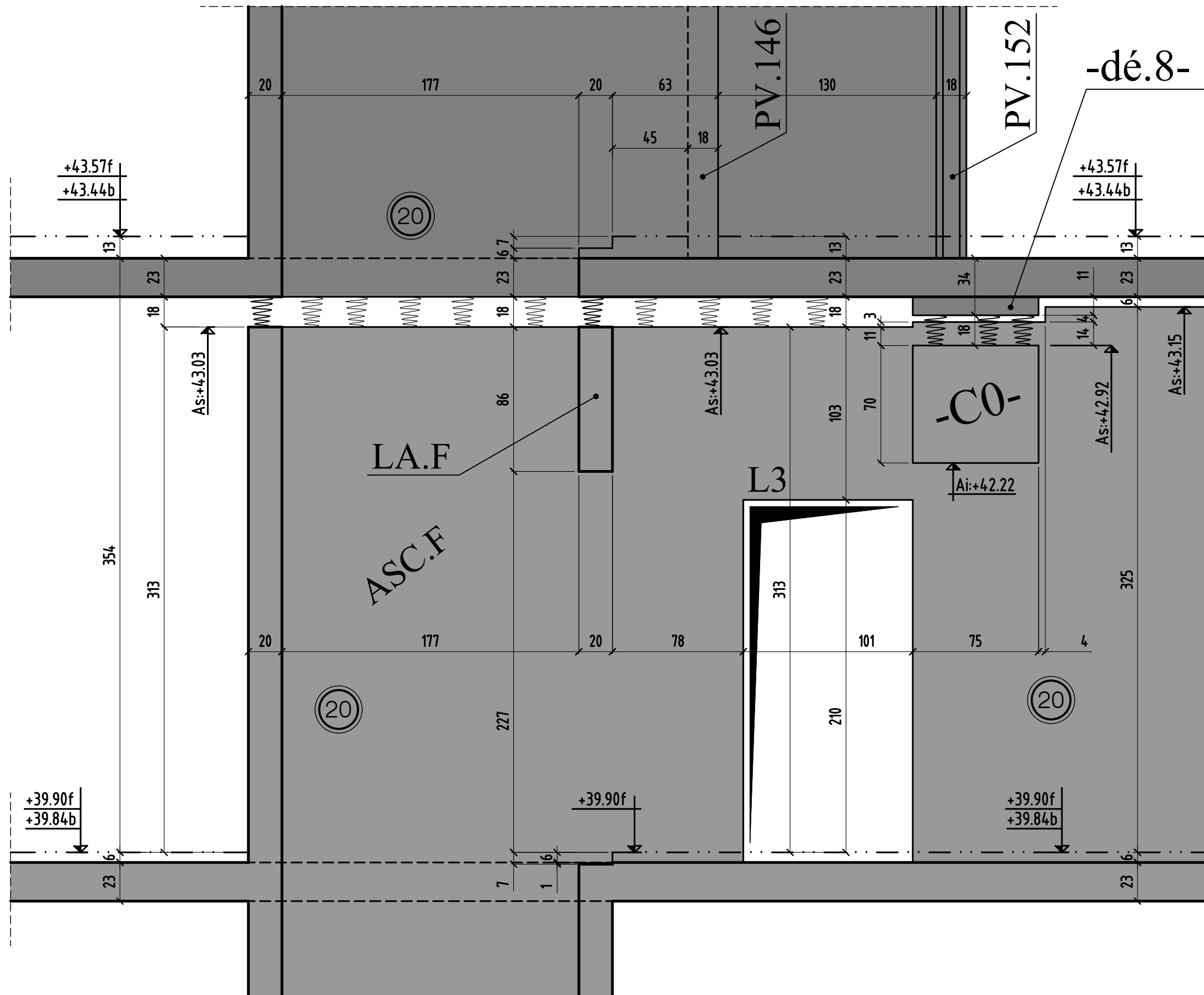

coupe 66-66

MODIFICATIONS		A	AFFAIRE:294	Cahier C.35
0		B	Ech:1/25	Page 12

# COUPE 68-68

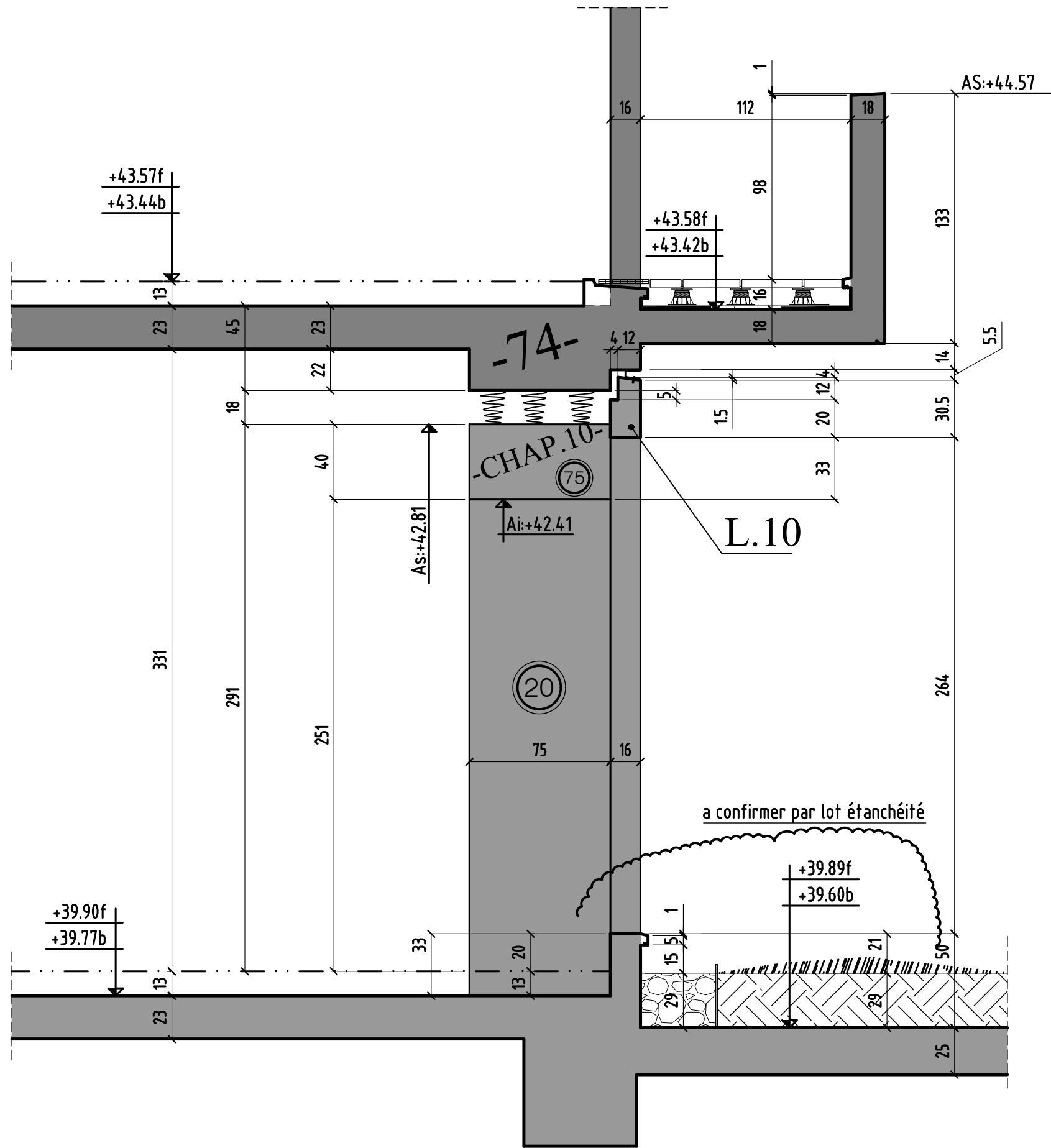

coupe 68-68

MODIFICATIONS		A	AFFAIRE:294	Cahier C.35
0		B	Ech:1/25	Page 13



COUPE 69-69

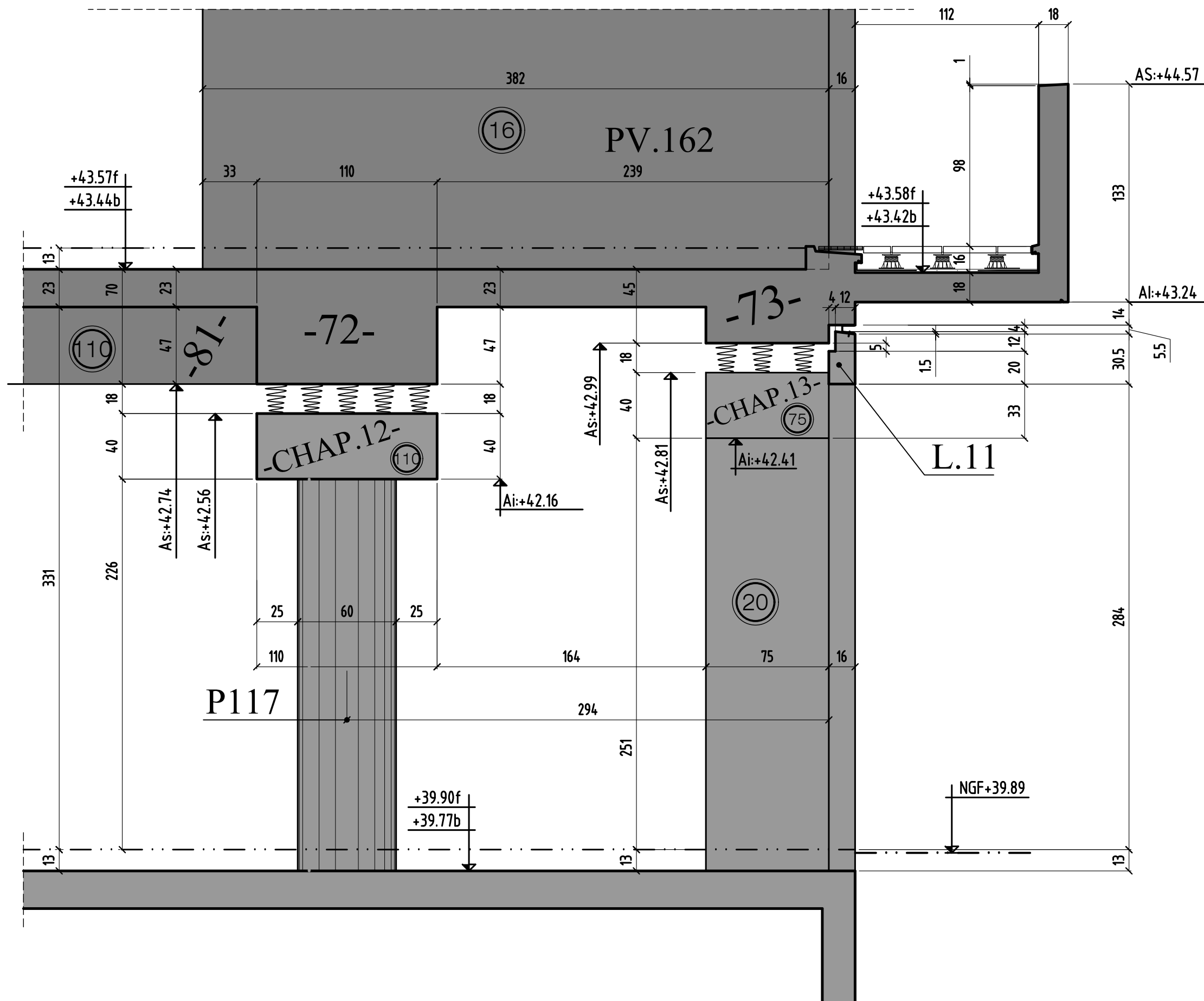

# COUPE 71-71

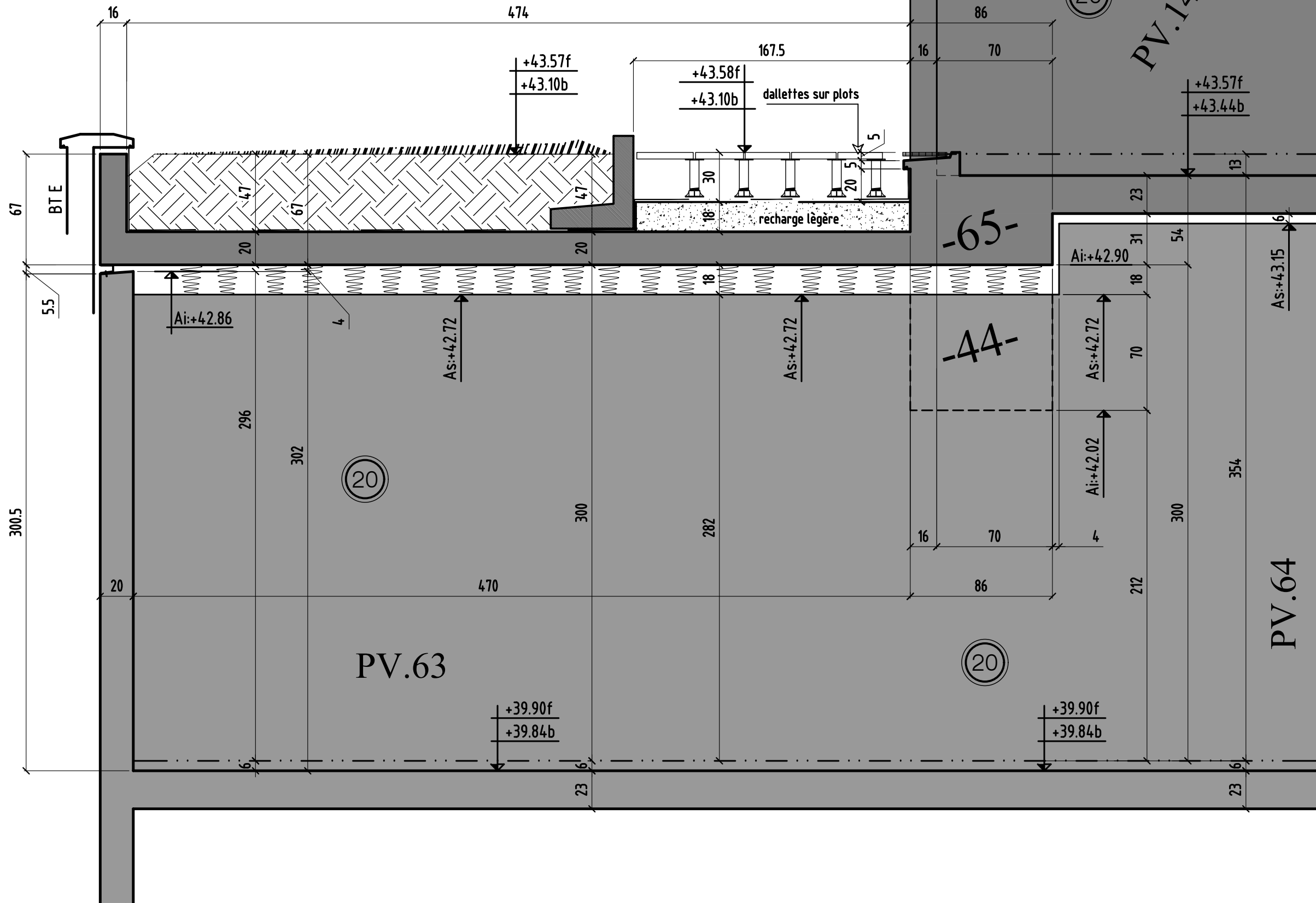

coupe 71-71

0	MODIFICATIONS	A	AFFAIRE:294	Cahier C.35
		B	Ech:1/25	Page 15

# COUPE 72-72

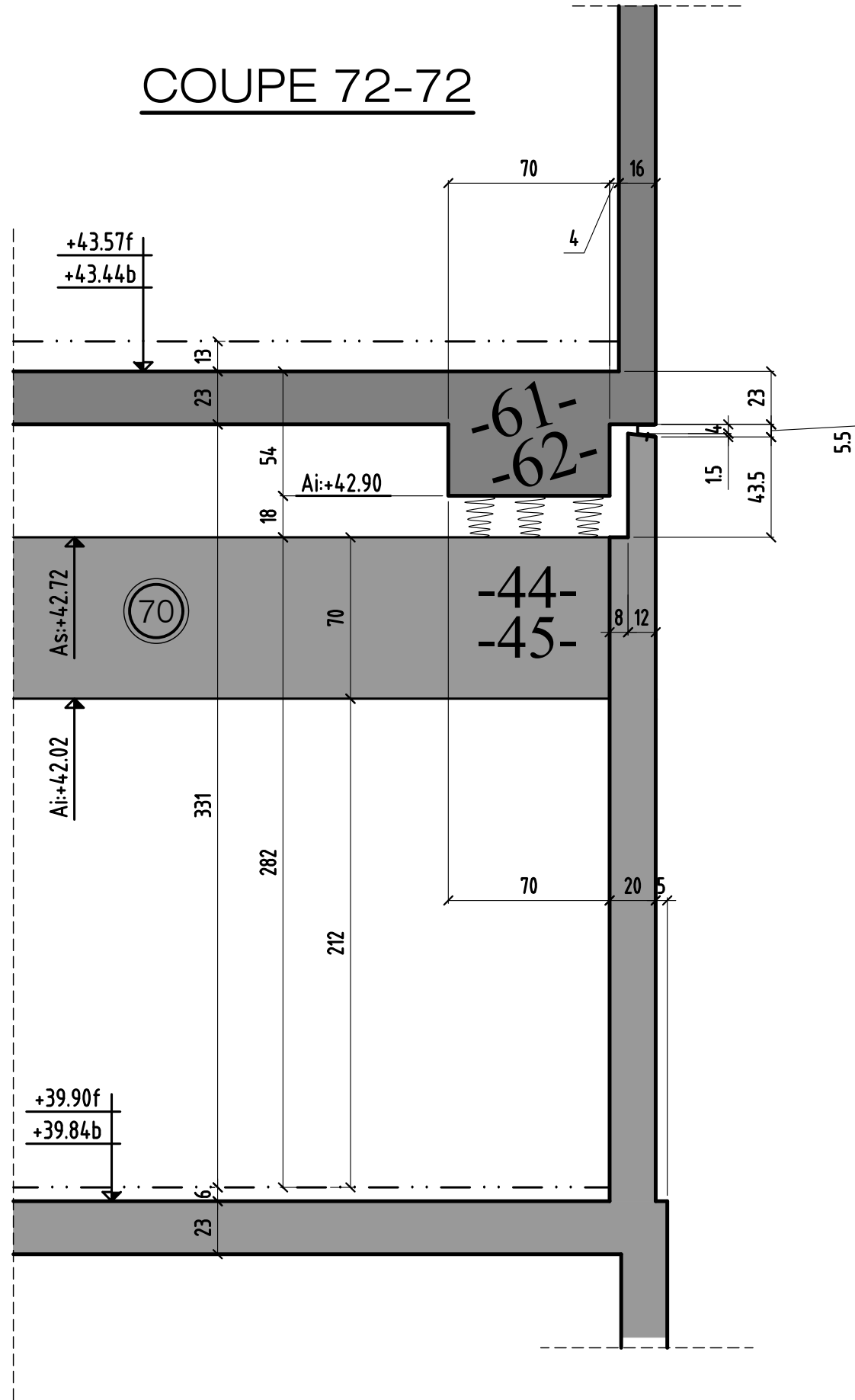

# COUPE 73-73

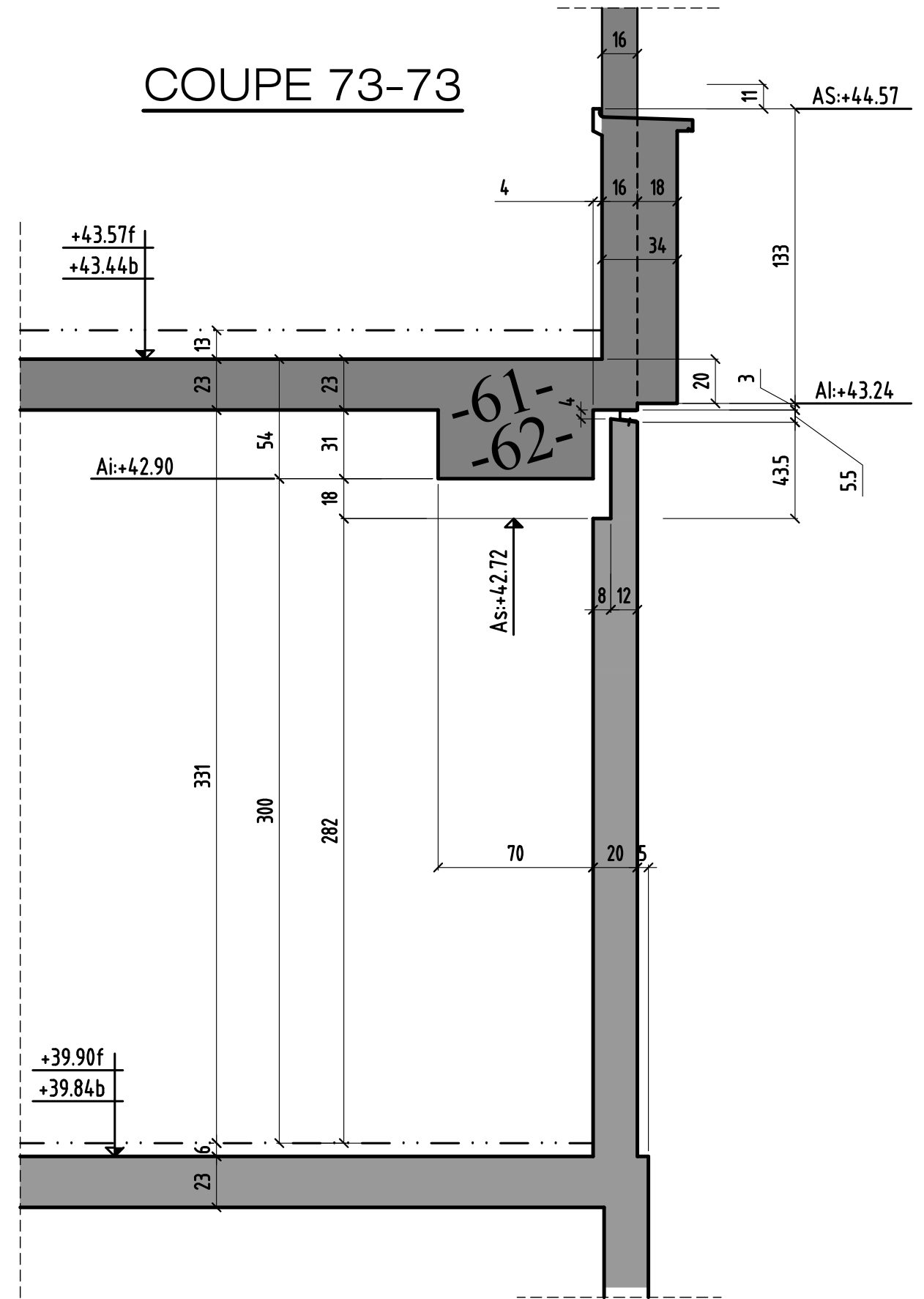

0	MODIFICATIONS	A	AFFAIRE:294	Cahier C.35
		B	Ech:1/25	Page 16